



**VOLUME-II
M&E SERVICES
TECHNICAL
SPECIFICATION**

LIFT SPECIFICATIONS
&
SELECTION OF MATERIAL

Subject: - Supply, installation, testing and commissioning of Fully Automatic Glass Elevator at Annabhau Sathe Auditorium, Byculla in E Ward.

Specifications for “Elevator /Lift”

Description :- Supply and installation ,testing & commissioning of “Fully Automatic Glass elevator” with machine room less (MRL) PM gearless machine, polyurethane coated flat steel belts, pulse monitoring device, overload indicator, voice synthesizer / car chime, auto fan cut off, speed limit (safety) switches, intercom, attendant service, nudging, infra red 2D curtains throughout the landing gate, all necessary accessories and as per the specification below approved by state PWD and MCGM. The lift shall consist of cage with toughened glass enclosed on two sides and SS finish for operating console .

Note :- This lift shall provided for senior citizen/ handicap persons in this auditorium ,hence all handicap person related government norms shall be fulfilled by the lift vendor. Also comply all safety /fire norms related to lift services.

The size of the shaft is as per the Architectural details.

- 1) **Brand :** OTIS/ Mitsubishi / Kone / Schindler/Thyssenkrup.
 - 2) **Load :** 480kg.
 - 3) **Speed :** 1 MPS.
 - 4) **Rise :** 11.7 meters. (Some of the landings might be have unequal landings.)
 - 5) **Stop and Openings :** As per Site 3/3
 - 6) **Control :** AC VVVF (variable voltage variable frequency) with close loop.
 - 7) **Power Supply :** 400 volts, 3 phase, 50 hz, alternating current.
 - 8) **Operation :** Simplex full collective with/without attendant service.
 - 9) **Machine :** PM synchronous gearless.
 - 10) **Car size :** 1100 (width) x 1050 (depth) x 2700 (height).
 - 11) **Hoist way size :** 1900mm x 1600mm (clear inside).
 - 12) **Car enclosure :** 12mm Toughened glass enclosed on 2 sides with SS railing and SS hairline for operating console.
 - 13) **Handrails :** Stainless steel in mirror Finish on three sides.
 - 14) **False Ceiling :** CD 34 Powder painted .
 - 15) **Flooring :** Granite 20mm thickness .
 - 16) **Car entrance :** Protected by two speed SS framed 12 mm toughened glass door in hairline finish (for SS).
 - 17) **Car opening :** 800mm x 2400mm.
 - 18) **Door operation :** Automatic and multi ray electronic door detector system Signals:S60
- 1) Combined Luminous hall button with seven segment digital hall position indicator at all floors
 - 2) Car operating panels with luminous floor buttons in car.
 - 3) Seven segment digital car position indicators in car.
 - 4) Battery operated alarm bell and Emergency light.
 - 5) Firemen's switch at main lobby.

6) Overload warning device.

7) Automatic rescue device.

Notes: 1) Rate shall include minor/major civil work, scaffolding, electrical works, dismantling, PWD fees and related liasoning cost, steel structure items, etc

2) The quoted price shall be inclusive of all the taxes in GST and all other applicable taxes. This quotation shall not be subject to IEEMA price variation cost.

3) The contractor shall make necessary arrangements to provide suitable lockable weather proof storage space for the materials and shall also stack the existing dismantled material in a safe secure place for the disposal of the municipal authorities.

4) The contractor shall include in the quotation 36 months free maintenance which will be commenced from the date of completion of project.

5) The cost shall be inclusive of all preparatory work required by the lift vendor and no extra cost will be provided towards this item.

The rate shall include comprehensive maintenance of all equipments for 36 months by Vendor for Defect Liability Period of 36 Months.

Instructions to Lift vendor /contractor

1. Contractor shall visit the site to get information regarding site constraint if any.
2. Bidder /Lift OEM shall submit feasibility report for lift installation as per site constraint & select suitable lift location as per user /client requirement.
3. Contractor shall sole responsible to obtain all the NOC's of statutory bodies.
4. Location of installation of lift/elevator shall be jointly confirmed with user department.
5. Contractor shall take cognizance with Engineers In charge /PMC / structural engineers before starting the work.
6. Material shall be of 1st quality only. All civil / electrical / mechanical cost are included in cost. All electrical wiring, panels are included in lift vendor scope. Only input power supply DP mcb for lift power shall be provided.
7. Lift proposed from parking area i.e. basement +ground floor + first floor (B+G+F=3 Stop) If any stop reduced, then proportionate deduction in total cost as approved by BMC authority will be deducted from total quoted cost.

1.0 GENERAL

The Standard Technical Specifications are to be read in conjunction with the Detailed Technical Specifications as the latter are intended to amplify the former; only those portions of the General Technical Specifications which apply to the actual project involved shall be pertinent.

Where Detailed Technical Specifications are at variance with General Technical Specifications, the former shall prevail as its contents relate directly to the specific project.

The specification is intended to cover the complete installation of the lift installation and its equipment. It is intended to outline the minimum equipment required, but does not necessarily cover all the details of the installation design and construction.

It is acknowledged that such details are recognized as being the exclusive responsibility of the lift contractor who is more familiar with the product offering intricacies and installation methodologies.

The contractor may not however deviate from the following which are detailed in the detailed specifications;

- A)Load capacities,
- B)Speeds,
- C)Control systems,
- D)Materials and finishes,
- E)Performance
- F)Installation criteria as may be applicable.

In all cases where a device or part of the equipment is referred to in the singular, it is intended that such reference shall apply to identical installations or devices which are required to complete the total installation.

For Example; where information on a singular lift is specified in a duplex pair, the specification shall apply equally to the duplicate lift unless otherwise stated.

Where the manufacturer's requirements or design parameters may be in conflict with this specification, this specification shall have precedence.

Note: The intention of this specification is to call for equipment that is currently available in the Indian market.

It is designed to establish the minimum requirements with regard to the end product from a selection of manufacturers and suppliers where their product offering can be evaluated against measurable criteria.

It is the intention that the successful contractor will be responsible for the complete scope of this tender. Where in these specifications it is provided for something to be done it shall be the responsibility of the Lift Contractor to do so. This applies to those scopes of works that may be required to be sub-contracted to other specialist contractors, such as shop fitting, minor building patch up works, painting and so forth. Such items are not to be omitted from the tender and are to form part of the contract sum unless the specifications expressly state that someone else is responsible for those items.

1.1 COMPLIANCE WITH REGULATIONS & QUALIFICATIONS

The installation shall be erected and carried out in compliance with:

- a) All applicable Electric Lifts and Service Lifts as amended

- b) The Local Municipal Bye-Laws and regulations as well as the regulations of the Local Supply Authority
- c) National Building Regulations and Building Standards Act
- d) The Local Fire Regulations
- e) The Standard Regulations of any Government Department or Public Service company where applicable.
- f) All applicable Code of Practice or Regulations for disabled.

Note: It is the duty of the Contractor to timeously inform the Consulting Engineer in writing whether by design or unintentionally there is any portion of this specification that does not fully comply with any applicable regulation. The Contractor shall provide proof that his product offering fully complies with all of the relevant statutory requirements.

i. In addition, the contractor shall issue all notices and pay all the required fees in respect of the installations to the Local Authorities, and shall exempt the Employer and Consulting Engineer from all losses, costs or expenditure which may arise as a result of the contractor's negligence to comply with the requirements of the regulations enumerated in above paragraph

ii. It shall be assumed that the Contractor is conversant with the abovementioned requirements. Should any requirement, bye-law or regulation, which contradicts the requirements of this document, apply or become applicable during erection of the installation, such requirement, bye-law or regulation shall overrule this document and the contractor shall immediately inform the Consulting Engineer of such a contradiction. Under no circumstances shall the contractor carry out any variations to the installation in terms of such contradictions without obtaining the written permission to do so from the consulting engineer.

iii. The Contractor shall furnish a document which gives a complete description of all equipment wherein the product proposed does not comply with the specification or information provided in this document, or is in conflict with the work of other trades as specified or shown in other Works Information. Failure for furnish such a document shall be interpreted to mean that the Contractor agrees to meet all requirements of the Specification.

iv. The Contractor may not offer alternative equipment and/or shaft and motor room designs in a covering letter, drawings or tender supplementary documentation, without making specific reference to such deviations.

v. It is expected that the Contractor will disclose any deviation from the specification and submit supporting documentation motivating the offer of alternatives. The Consulting Engineer reserves the right to include or disqualify the tender, should in his opinion the offering is not in the best interest of the Employer. This is expanded in the next section.

1.2 **DEVIATIONS TO SPECIFICATIONS CRITERIA**

Where the words for approval or approved are used and it is desired to substitute a different make or type of apparatus from that specified, all information pertinent to the adequacy and adaptability of the proposed equipment shall be submitted to the Consulting Engineer for approval prior to the equipment being ordered or released for manufacture.

Approvals for equipment specified or proposed substitutions shall not be given merely upon the submission of Manufacture's part names, detailed documentation together with motivation to accept the substitution shall be required.

Approvals for all equipment submitted as a substitution for that specified or shown on the drawings may be granted if such equipment meets the intended and anticipated requirements pertaining to performance, reliability, operation, space conditions, weight, and quality of equipment.

i. Deviations without written acceptance from the Consulting Engineer from the Scope of Works and Information shall not be accepted. The Contractor shall verify in the tender covering letter, that they have read and understand the content, meaning and intentions of the Tender Document and have tendered accordingly.

ii. Where technical specification cannot be met in terms of specific design requirements; substitution or alternative equipment will be considered with the provision that the proposed substituted equipment will not in any form or manner reduce the intended performance, operation, duty- rate, redundancy and reliability of equipment of the final installation. Deviation or substituted equipment not clearly shown and detailed in a covering letter under the headings, 'DEVIATIONS' shall not be considered or accepted and could result in the disqualification of the tender.

iii. Tender supplementary documentation, brochures etc showing the technical details such as load, speed, dimension sizes, performance and operation of the equipment offered and Contractors conditions of Contract, shall only serve as an informative supportive documentation in terms of the equipment offered, program, organization and staff, and alternatives offered and shall not be considered an acceptable qualification in terms of the Detailed Specification. Equipment offered as substitution that does not comply with Item - 4.3.2 of this specification, whether or not shown in the supplementary document shall not be accepted.

iv. It is acknowledged that the lift technology is advancing with the introduction of new designs, equipment and components.

v. This specification provides for minimum technical requirements with respect to design, operation, reliability, performance and after service requirements. The Employer and Consulting Engineer reserve the right to reject in whole or part thereof any product offered that in their opinion does not comply with this specification. The following equipment components offered in terms of this specification shall be clearly detailed in the tender supplementary documentation and shall be confirmed by the Contractor as the most modern, latest, technically advanced and most reliable equipment available:

- Car and landing signals,
- Car and landing call button units,
- Door drive equipment,
- Door protection devices,
- Control equipment,
- Drive equipment,
- Intercom equipment.

vi. Approval for alternative equipment shall be by the Consulting Engineer in his capacity as the Employers representative. Contractors are welcome to seek approval for alternatives; however the Contractor shall be liable for all costs associated with providing alternative equipment that has not been duly authorized with any recourse back to the Employer or Consulting Engineer.

1.3 **ALTERNATIVES COSTS**

i. The Employer or Consulting Engineer may consider alternatives based on grounds of cost if alternatives do not negatively affect the specified performance levels, operation, reliability, duty-rate, and product expectation. Without deviating from the Main Offer, Contractors' are to provide the following information for any alternative offered;

- Cost breakdown,
- Cost to fix local content,
- Forward cover as specified,
- Programme as specified,
- Statement of installation as specified,
- Maintenance cost as specified,
- Technical information and pamphlets as specified.

ii. Provide a deviation schedule and show all costs in the Contact Price Summary which can be found at the end of the document

iii. It is noted that all alternatives presented and accepted by the Employer and Consulting Engineer shall comply in full with the Conditions of contract as contained in this specification and shall not be limited to performance, operation, reliability, duty rate and quality of equipment.

1.4 **DRIVE MACHINE**

The main driving machine shall be gearless with a synchronous permanent-magnet motor. It shall be provided with a dual solenoid service and emergency brake of a disc or drum configuration. The machine must be of a design which can be mounted in the hoist way.

Bearings are to be liberally dimensioned and provided with automatic lubrication. Machine for all intents and purposes should be as maintenance free as is practically possible and comply fully with amended provisions of the applicable SANS code.

1.5 **GEARING**

If applicable:

The worm and its shaft shall be turned and machined from one piece of high quality steel. The worm wheel must be provided with a phosphor bronze rim with machined teeth. The worm wheel shaft shall run in sleeve bearings, while double thrust ball bearings must be provided to take up the axial thrust. Thrust bearings shall be removable without complete dismantling of the machine.

The gearing must be enclosed in a cast iron case, provided with automatic oil lubrication.

This case is to be equipped with lids for easy inspection of the gear, and provided with an oil level indicator as well as oil filling and draining openings.

As an alternative, the machinery may be supplied with roller bearings instead of sleeve bearings provided silent operation can be guaranteed.

1.6 **VVVF DRIVE MOTOR**

The main driving motor shall be VVVF closed loop AC driven specially designed to operate at low speed controlled by variable voltage combined with variable frequency. The main driving motor shall be compatible for Variable Voltage, Variable Frequency AC drive of the squirrel cage multi-pole shunt wound type, specially designed for lift hoisting work, and so dimensioned, that no parts of the motor can become overheated under normal site and service conditions.

1.7 **DRIVE SHEAVE**

The drive must consist of a traction sheave in which the requisite number of grooves has been cut to suit the number and size of ropes used. This sheave is to be mounted on the same shaft as the worm wheel or drive machine, whichever is the case. The shaft shall have an outer bearing with automatic lubrication. The driving sheave shall be easily removable for renewal of the grooved rim.

1.8 **BRAKE**

The brake drum may be incorporated in the coupling between the worm shaft and the driving motor or for gearless applications as part of the sheave drive. The brake may be operated by a DC solenoid. The brake must be easily adjustable and one half of it must be capable of holding the car in case of failure of the other half. The brake arrangement must be so designed and installed that should the worm shaft shear, the brake

will be prevent the traction sheave from turning.

1.9 **HAND TURNING GEAR**

Provision shall be made for a safe method of turning the machine by hand so that the lift car can be moved manually from the lift motor room or top floor landing to the nearest landing to facilitate evacuation of passengers.

1.10 **CONTROLLER**

The controlling mechanism for Motor Room Less type lift shall not be mounted on the main machinery but is to be assembled as part of the top floor landing door framework.

Contacts breaking heavy currents shall be provided with magnetic blow-outs or arc chutes. All contact surfaces shall be of silver, except those for heavy currents, where carbon to silver or carbon to copper surfaces may be used. Copper to copper contact will not be accepted.

Wearing parts must be easily renewable. If applicable, flexible connections must be used for all moving contacts and currents shall not be carried by springs or joints.

For the wiring of the controller, fire resistant cables are to be used.

The controller must incorporate all switchgear and relays necessary for the operation and protection of the lift, and must be so designed that it will automatically bring the car to rest in the event of any of the following occurrences:

- i. Interruption of the power supply to the machinery or interruption of any one phase of the main supply.
- ii. Operation of the governor due to over-speed condition.
- iii. A reversal of power supply phase/s.
- iv. Interruption of car door or landing door locks
- v. Overload of drive motor
- vi. Interruption of terminal limits

All terminals of the machinery and the control gear must be marked with a distinctive letter or number and corresponding markings shall appear on the engineering installation drawings.

1.11 **OPERATION**

The operation of the lift/s shall be Collective Simplex control and operation system whereby a common pushbutton control panel/s for the lift/s is provided on the landing at each floor level.

The landing panel shall be equipped with both UP and DOWN call buttons except on terminal floors where Single call buttons depicting the reversed direction of travel shall be installed.

Landing and car calls shall be continuously registered by the controller so that landing calls are allocated to both cars so as to avoid waiting time.

1.12 **CAR CONTROL BUTTONS**

The operating panel in each of the lift cars shall be equipped with the following controls:

- i. A number of pushbuttons corresponding to the number of floors served.
- ii. A button clearly marked ALARM to sound a battery operated bell mounted on top of the lift car in a position indicated by the Consulting Engineer.
- iii. A door OPEN and a door CLOSE button.
- iv. A key operated bypass switch to separate the controls of collective operation.
- v. A key operated switch for the car lighting.
- vi. Switches to operate the lift car fan.
- vii. Any other pushbuttons which may be necessary should first be reviewed by the consulting engineer
- viii. Independent reservation key switch operation shall be provided in the car operating panel.

All these pushbuttons shall be micro touch sensitive type and shall blend with the overall design of the car interior as described and shall each be fitted with an LED indicator showing that the call has been registered.

A set of car control buttons termed “Car Top Station” for up and down operation of the car shall be fitted into a dustproof control box positioned above the roof of each of the car/s.

These controls shall override all other travel controls and assist in manually operating the car travel in the shaft for maintenance and inspection of the shaft.

A 15 Amp 3-pin switched industrial metal clad socket outlet as well as a bulk head light fitting for 100 watt ES incandescent lamp and switch is to be provided above the platform adjacent to the controls.

Immobilizing switches located on the top of the lift car shall also be fitted for inspection purposes.

1.13 **LANDING CONTROL BUTTONS**

These pushbuttons shall be micro touch sensitive type to match other similar items of equipment and shall be mounted into a sheet metal front for flush mounting into the face-work of the piers between the lifts in the inline position. Each button shall be provided with an LED indicator showing that the call has been registered.

The lower and upper terminal stops shall only have one pushbutton each while the intermediary stops shall have an UP and DOWN pushbutton each with LED indicators.

On the Ground Floor a Fireman’s control station with toggle switch recessed mounted behind a flush glass fronted box shall be installed in the lift lobby.

The face plates of all these landing control buttons shall be stainless steel “Brushed Satin” finish.

1.14 **SIGNALS**

The following signals and indicators shall be provided:

In the Car

- (a) Illuminated travel direction indicators with arrows mounted on the car operating panel.
- (b) An illuminated position indicator to be provided in each car to indicate the landing served.
- (c) Signal to indicate that the lift is overloaded
- (d) Signal to indicate that the lift is on reservation service
- (e) Signal to indicate that lift is out of service
- (f) Signal to indicate that Fireman’s service has been activated and lift is returning to designated floor.

On Each Landing

- (g) Illuminated direction of travel indicators with arrows each with electronic gongs to announce car arrival shall be fitted above each landing door of each lift.
- (h) The micro pushbutton station/s.
- (i) Each lift landing shall be provided with an illuminated multi-position indicator indicating the position of each car. These indicators shall be flush mounted above each landing door of each lift.

1.15 **OPERATING INSTRUCTIONS**

All operating instructions and engravings on the operating panel of each of the cars shall be in English/Marathi/Hindi

Alternatively:

Universal language pictograms may be used with English/Marathi only for the inscription plate.

1.16 **LIFT CARS**

Each of the lift cars shall conform to the following requirements:

Construction

GENERALLY

The body of the car shall be self-supporting and insulated against transmission of noise and tenderers shall submit various designs, brochures and illustrations as well as the required technical data on the lift car and alternatives which have been included in their tender.

Car Frame

The car frame shall consist of rolled steel sections, channel and angle folded and welded with substantial reinforcement and braced to prevent distortion and to relieve the car enclosure of all strains and unwanted movement during travel.

Platform

The platforms shall consist of plates of steel laid on framework with granite (floor finish) 20 mm thick.

Roof

The roof of each car shall be provided with a suitably constructed and reinforced platform above the ceiling to carry the weight of 3 men of an average weight per man of 75kg who shall be carrying out the maintenance and inspection work to the shaft.

Car Body

The car body shall be constructed from 14 gauge sheet metal panels with rubber insulation between the metal parts to ensure low vibration and limited noise transmission. For painted finishes, the panels must be thoroughly bonderised before painting and the outside of the car shall receive a coat of rust preventative paint. The interior finish and decor to the lift car shall be fitted to interior of the car body.

Observation lifts shall have minimum 8 mm laminated safety glass panels.

Ceiling and Lighting

Ceiling and Lighting final finishes shall be approved by the Architects. For tendering purposes the minimum standard shall be illuminated ceiling with insert diffuser panels or acrylic cylinders shall be provided to suit the interior decor of the car. The lighting within the car shall be fluorescent tubes with electronic ballast or down lighters to give a minimum of 50 Lux.

In the event of a mains failure an emergency battery powered light source will be provided that complies with the minimum standards stipulated in SANS codes.

Ventilation

A single speed fan shall be mounted above the lighting diffuser to give adequate ventilation controlled by a toggle switch mounted in the control panel in the wall of the car.

Control Panel

The car control panel shall form part of the car front or side wall and shall extend from the car floor kick-plate up to the ceiling.

The cover shall be movable or hinged for easy access to the controls and wiring and finished in stainless steel brushed satin finish.

The components of the control panel shall be:

- (a) Digital car position indicator.
- (b) Maker's nameplate inscribed with service instructions, nominal load, number of persons and official registration number.
- (c) The operating section containing buttons for landings with LED indicating call registered, alarm button, touch buttons for door opening and closing, key switches as required, overload indicator etc.
- (d) No smoking sign.
- (e) A recessed Telephone cabinet to accommodate an intercom telephone handset or normal telephone handset linked to the PABX system or security room. (this item should be confirmed in the detailed specification guide.

(f) For Hospital applications, a recessed box with a hinged door to accommodate emergency oxygen bottle.

Hand Rails

A handrail shall be provided, manufactured from stainless steel or aluminum in “Brushed Satin” finish and shall be fitted around all three sides of the lift cars. In the event of semi scenic cars being provided the handrail at the rear of the car shall be strengthened and securely fastened to the side and rear wall of the cars.

Kick Plate

A stainless steel kick plate at least 150mm high shall be fitted to extend around all three sides of the lift cars at floor level.

1.17 CAR AND LANDING DOORS

These doors shall be specified according to shaft requirements with finish to architect’s requirements.

All doors are to be constructed of hollow metal adequately soundproof framework and suitably reinforced to ensure rigidity. The exterior finish to be laminated stainless steel with 8 mm laminated safety glass for the doors.

All car doors are to be power operated and provided with a mechanical attachment which shall open and close car and landing doors simultaneously.

The doors shall be interlocked by electronic mechanical locks, so arranged that no landing door can be opened unless the car is opposite the landing and that the car cannot be started unless all doors are closed and latched.

The locks shall be substantially constructed, sufficiently strong to withstand the shock of the repeated opening and closing of doors. The locks and contacts shall be so enclosed as to prevent accidental contact by any person using or working the lift. When the car arrives at the landing, car and landing doors shall start opening while the car is leveling.

When the lift button is initiated and the doors begin to close, it must be possible to quickly reverse and open doors.

To prevent injury to passengers, the leading edges of the car doors shall have a full curtain detector, so adjusted that when the closing door meets an obstruction it shall automatically re-open.

In the event of a power failure it must be possible to open car and landing doors from inside the car, provided it has stopped within a reasonable distance of a landing level, i.e. within the leveling zone. Door release keys for opening landing doors from the landing are to be provided to the client and the tenderer shall provide training in the use thereof.

1.18 LANDING ENTRANCES

At all landings served by all lifts, extended aluminum sills with anti-slip tread are to be provided. The sills must be securely fixed to the building construction and must line up with the final floor finish. Floor nibs for the attachment of sills will not be provided.

At each landing the entrances shall be provided with simple but robust stainless steel architraves finished in “Brushed Satin”.

1.19 DOOR HANGERS AND TRACKS

Each car and landing door must be equipped with suspension hangers and rollers running on suitable tracks. The rollers must be adjustable and shall be suitably protected against dust and dirt. The hangers must be easily accessible.

The hanger housing shall be of steel, suitable reinforced and shall be adequately supported and securely fixed in position.

1.20 FASCIA PLATES

Plates not less than 16 gauge, reinforced where necessary, shall be fitted on the inside of the shaft

between all entrances, extending from the hanger housing to the sill above. The plates shall be at least 150mm wider than the shaft openings. The plates must be coated with rust-resisting paint.

1.21 **SAFETY DEVICE**

Each lift shall be provided with a safety device, fitted to the underside of the car, and designed to bring the car gradually to a standstill without shock, when the speed in the downward direction becomes too great. Details of the type of "safety" offered must be given.

1.22 **GOVERNOR**

Each lift must be provided with a tension type governor, driven directly by an independent rope attached to the car, and adjusted to interrupt the motor supply when the car speed exceeds the normal speed by approximately 15% and to apply the safety device when the over-speed is approximately 25%.

1.23 **GUIDES**

The guides for each car and counterweight shall consist of planned steel tees with milled, tongued and grooved joints. Metal splice plates shall be at least 300mm long. The bases of each set of guides shall be bolted to horizontal steel channels fixed to the pit floor. Side counterweight arrangements shall have a dual purpose bracket that combines both counterweight guide rails, and one of the car guide rails to building fastening.

1.24 **BUFFERS**

Two heavy spring or oil buffers or equivalent are to be provided for each car and for each counterweight.

The buffers shall be so adjusted that in case of over-travel no parts of the counterweight or car will touch the shaft ceiling, and that the retardation of the car does not exceed the limits laid down in the SABS 1545, EN81 or British Standards Safety Codes.

1.25 **COUNTERWEIGHTS**

Each counterweight shall consist of a structural steel frame, in which independent cast iron weights are to be assembled.

When lift shafts are above occupied floors, the counterweights are to be fitted with a safety device to prevent the counterweight falling freely.

Counterweight screen is to be provided in the pit and counterweight is to be painted chevron black & yellow.

1.26 **GUIDE SHOES**

The shoes shall be of the spring loaded type, provided with automatic oil feed lubrication.

The shoes shall have ample bearing surfaces, and shall be easily adjustable and removable for renewal.

1.27 **HOISTING ROPES**

The ropes shall be of the best quality steel wire rope available, and total the required number for the duty load of the lift. Ropes of 8/19 construction are preferred.

Rope equalizers are to be so designed that each rope can be individually adjusted. Equalizers reducing the suspension to a single bolt or shaft will not be acceptable.

Contractor shall state if other suspension technology is to be used and provide details for approval of the consulting engineer.

1.28 **LIMIT SWITCHES**

Each lift shall be equipped with limit switches which will automatically stop the car at the terminal landings independently of the operating controller.

In addition final shaft limits are to be provided which shall disconnect the drive motor supply in the event of a control malfunction.

1.29 **TRIP RECORDER**

A suitable trip recorder shall be provided for each lift.

1.30 **WIRING**

Except for the flexible cable for the connections from the side of the shafts to the lift cars, all other wiring is to be carried out in PVC conduiting, screwed tubing or in folded metal or PVC ducting. Should screwed conduit be used then a liberal number of inspection fittings must be provided and the tubing must be of such diameter that the wiring can easily be renewed.

Sheet metal ducting for the control circuits in the shafts and motor rooms is permissible provided this ducting complies with the requirements of the electrical code of practice.

Cable lugs shall be used for all stranded wires, and small wires shall be connected with suitable terminals.

All tubing and ironwork shall be thoroughly earthed in accordance with the regulations.

1.31 **PAINTING**

All ironwork and the floor of the lift machinery room & shaft, except contact surfaces of the guides shall be painted with two coats of best quality paint.

1.32 **TOOLS**

Only if applicable, these shall be in the motor rooms comprise of a complete set of large tools and special devices shall be provided mounted on a suitable tool board which is to be fixed to the motor room wall. Tenderers must state what tools will be provided.

1.33 **ESCALATORS**

NOT APPLICABLE

1.34 **TENDER DRAWINGS AND TECHNICAL INFORMATION REQUIRED**

Tenderers must submit with their tender, detailed drawings showing the proposed lift and/or escalator installation and the layout of the motor room.

A detailed description of the lift and escalator installation offered, and of the method of operation must be furnished.

In addition tenderers must complete the technical data schedules attached to this specification.

Failure to submit any of the required information may disqualify the tender.

1.35 **ENGINEERING INSTALLATION DRAWINGS**

The drawings listed below shall all be prepared by the Lift Contractor and shall consist of:

General Arrangement Drawings

General arrangement drawings of both the electrical and mechanical systems indicating all equipment, testing, inspection, instrumentation, position and all access requirements.

Three copies of each shall be submitted before construction is commenced, but at least four weeks after the tender has been awarded and the Lift Contractor appointed.

Detail Design Drawings

The following detail design drawings shall be prepared and three copies of each shall be submitted for approval before construction is commenced.

ELECTRICAL SYSTEMS

General Arrangement Drawings Schematic and Circuit Diagrams Interconnection Diagrams

MECHANICAL SYSTEMS

General Arrangement Drawings Load and Force Diagrams Structural Steel Support Drawings

Builder's Work Drawings

These shall be based on the general arrangement drawings and shall show all the work to be done by others (holes in concrete, pockets, frames masonry holes, bases etc. as well as sizes, capacities and position of service connections by others for these contract works).

Five copies of each shall be submitted for approval before these are forwarded to the Builder for construction purposes.

Shop Drawings

Shop drawings which are based on the general arrangement drawings showing in detail the construction and all parts of the works, methods of assembly, erection and construction, thickness and types of materials, finishes, details of supports and anchorage, points, connections, welds, fabrication, fastenings, gaskets, sealants, reinforcements and all other pertinent details.

Three copies of these drawings are to be forwarded to the consultants for record purposes.

Wiring Diagrams

Wiring diagrams shall be prepared by the Lift Contractor indicating schematic and circuit layouts for all the equipment. Motor kilowatt and ratings for all circuit breakers and protective device settings shall be stated.

Three copies of each of these diagrams shall be provided to the consulting engineers for record purposes and a further copy of each printed by a permanent process shall be mounted behind a glass fronted frame fastened in a prominent position to the wall inside the lift motor room.

As-Built Drawings

The Lift Contractor shall keep a drawing record of all the deviations during construction from the General Arrangement plans originally prepared and shall mark those onto a set of "AS-BUILT" drawings indicating the exact positions of such items as conduit cable and ducting routes, joints, draw boxes etc.

These drawings shall be neatly prepared on transparent plastic for permanent record and shall be handed over to the consulting engineers at the completion of the Works and shall form a portion of the relevant clause of the handing and taking over of the installation.

1.36 OPERATING AND MAINTENANCE MANUALS

The Lift Contractor shall prepare and supply three copies of the Operating and Maintenance Manuals specifically for this installation.

The manuals shall include the following information:

- i. Detailed general arrangement and wiring diagrams as well as as-built drawings as described above.
- ii. Schedule of recommended spare parts necessary for at least a two year period of operation.
- iii. Schedules of manufacturer, address of local agent for each item of equipment and spare parts.
- iv. Schedule of recommended lubricants.
- v. A preventative maintenance programme for all equipment.
- vi. A draft copy of the manual shall be submitted to the consulting engineers for approval before the final issue of the three copies of the Operating and Maintenance Manual.
- vii. Copies of all applicable type test certificates
- viii. Copy of Annexure A
- ix. Copy of Annexure B
- x. Copy of lift registration document
- xi. Original rope certificate
- xii. Contact details for emergency call outs
- xiii.** Maintenance and operating documentation of any auxiliary equipment installed

1.37 MAINTENANCE TOOLS AND EQUIPMENT

The Lift Contractor shall provide all tools and equipment necessary for the proper and efficient execution of all construction and maintenance.

A complete set of all special tools required for the maintenance, operation and dismantling of all equipment shall be provided by the Lift Contractor. These items shall be neatly stored on a hanging tool rack fastened in a convenient position to the wall of the lift motor room.

Duplicate sets of keys to all doors fitted to control panels, instrument cabinets and locks shall be supplied by the Lift Contractor.

1.38 **SPARE PARTS**

The Lift Contractor shall include in his contract for the supply and provision of spare parts such as fuses, links, contacts, contactors, PC boards etc., and the like as are normally provided for maintenance of the equipment of the installation and the consulting engineers shall have the right to select such spare parts as deemed necessary for the proper care of the system. The lift contractor will provide guarantees that all parts will be available for a period of not less than 20 years.

1.39 **NOISE AND VIBRATION**

The equipment and plant provided shall be free from noise and vibration. If in the opinion of the consulting engineer any equipment, plant or apparatus operates with or transmits from it such noise and vibration to be objectionable then it will be necessary to rectify or replace such equipment or plant so that the service operates at conditions acceptable to the engineers.

The measures taken where necessary whether specifically stated in these documents or not to ensure quiet vibration free operation of the installation include for soundproofing of plant rooms, mounting of equipment on anti-vibration mountings, insertion of vibration isolators of the correct type, suspension of pipework, ducting and the like on suitable vibration excluding isolators so as to exclude the transmission of vibrations to the structure to which they are attached.

Remedial measures taken to achieve satisfactory noise and vibration levels shall be at no additional cost to the employer.

1.40 **NOTICES AND LABELS**

All notices and danger signs including prohibited, unauthorized entry, electric shock, procedure in case of fire, emergency telephone numbers etc., shall be provided by the Lift Contractor, securely fastened and displayed in prominent positions by him.

All manufacturers' nameplates shall remain intact and not removed from any plant or equipment. These nameplates shall have the ratings, type and model number as well as the manufacturer permanently embossed. The nameplates shall be securely fastened with screws or rivets to the main frames of the equipment.

The switchboards shall be fitted with clearly engraved labels identifying the switchgear and panels mounted above and in front of each panel respectively.

The lettering shall be engraved onto white-black-white Traffolite. Embossed and glued labels provided with adhesive material for fastening is not accepted.

The wiring of all switchboards and control circuits shall be marked with numbered porcelain or other approved ferrules to facilitate circuit identification.

1.41 **RECORDS**

The Lift Contractor shall provide and keep permanently on site a lift operation record book, besides the Operating and Maintenance Manual previously described.

The lift record book shall clearly show all visits, repairs, services, overhaul, maintenance, lubrication and inspections carried out as well as such stoppages and the remedial measures taken to repair and avoid such occurrences from re-occurring.

This book shall be signed by authorized persons only and be available for inspection by all such persons at all times.

1.42 **DATA SHEET TO BE FILLED**

DATA SHEET FOR Fully Automatic Glass Elevator

| Sr. No. | Description | Tenderer's Specifications |
|---------|--------------------------|---------------------------|
| 1 | Make of the offered Lift | |
| 2 | Model of the Lift | |
| 3 | Load | |
| 4 | Speed | |
| 5 | Rise | |
| 6 | Stop and Openings | |
| 7 | Control | |
| 8 | Power Supply | |
| 9 | Operation | |
| 10 | Machine | |
| 11 | Car size | |
| 12 | Hoist way size | |
| 13 | Car enclosure | |
| 14 | Handrails | |
| 15 | False Ceiling | |
| 16 | Flooring | |
| 17 | Car entrance | |
| 18 | Car opening | |
| 19 | Door operation | |

Tenderer's Signature & Seal

Technical specification for stage lighting and stage craft systems

Well engineered, designed and manufactured, of well designed and manufactured, GI hot dip galvanized Suspenders/clamps/brackets (bolttable/weldable) made out of MS 6 mm thick plates/MS 50x

50x 6 mm thick angles, MS M10/M12 studs and MS fasteners designed to suspend working platform at top stage, FOH catwalk and other relevant areas to suit as per the site condition.

Refer supporting leaflet or image and technical specifications No-1.

Mode of measurement and payment- Measurement and payment will be for complete one set comprising of all components as stated in above and BOQ

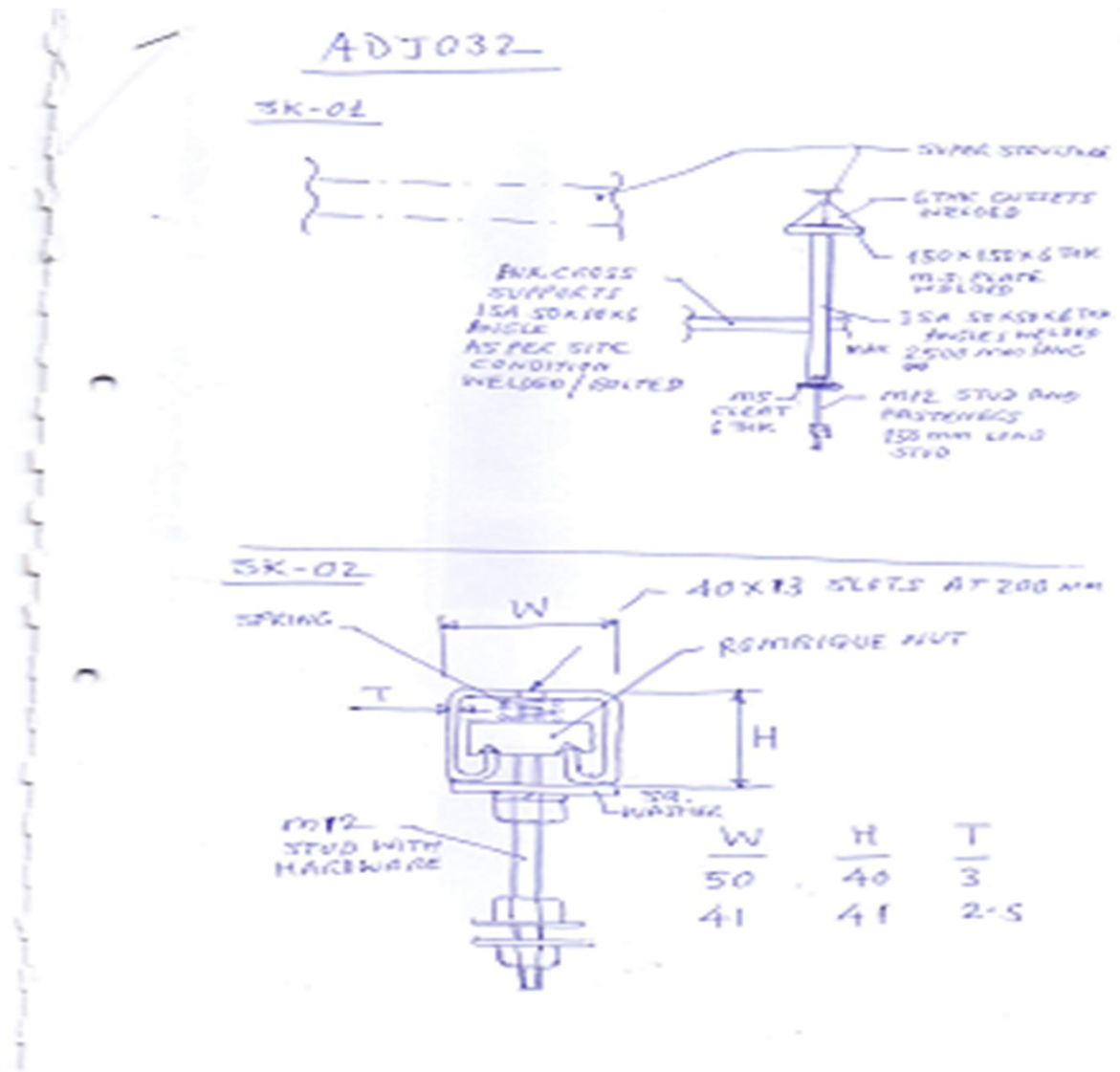

Well engineered, designed and manufactured, MS 'C' tracks suitable size made between minimum using 2.5 mm thick HR strip formed track size 41 mm x 41 mm and maximum using 3.0 mm thick HR strip formed track size 50 mm x 40 mm with extra inward 'U' bend for additional strength having 40 mm x 13 mm oval slots at 200mm intervals, hot dip galvanized or powder coated 60 microns black matt finish with proper chemical treatment and methodology. Along with required M10/M12 sliding rhombique nuts and relevant hardware, duly zinc plated.

Refer supporting leaflet or image bellow with technical specifications No-2.

Mode of measurement and payment- Measurement and payment will be for complete one set comprising of all components as stated in above and BOQ

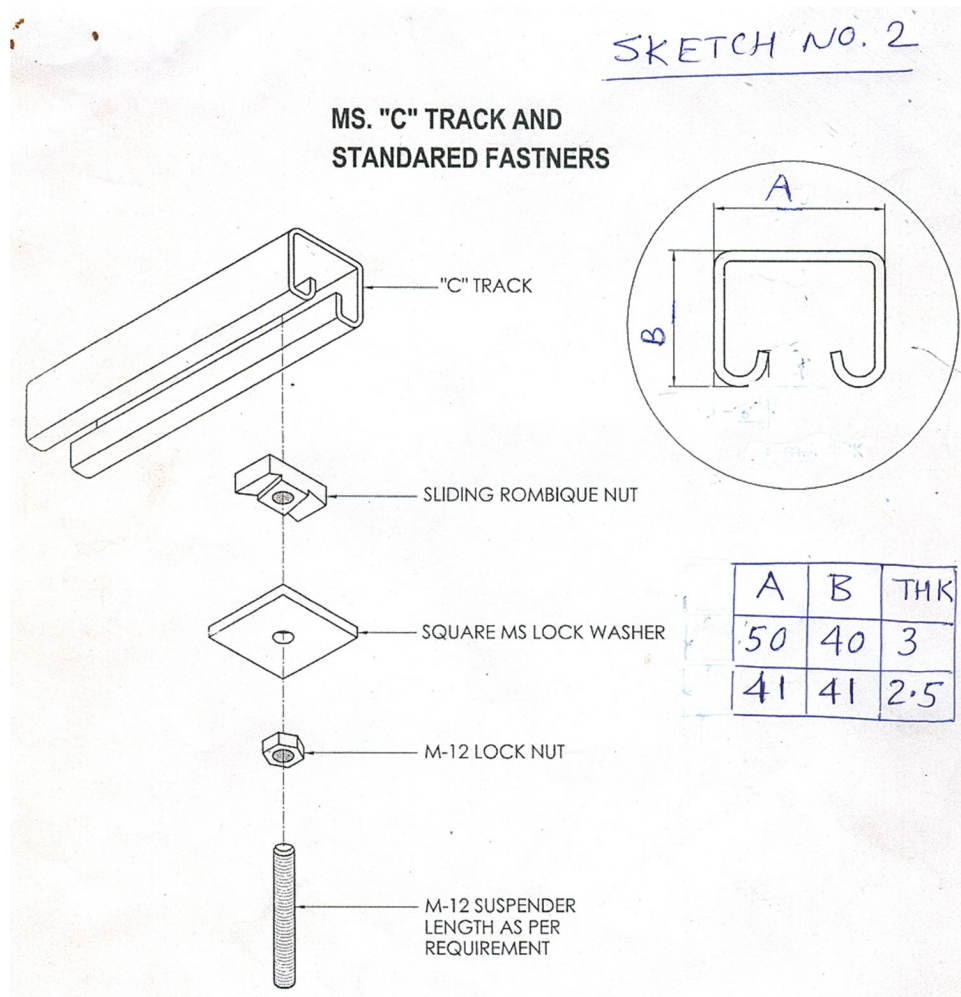

Well engineered, designed and manufactured of GI hot dip galvanised MS Grating (bolttable/weldable) made out of MS 3 mm thick x 20 mm wide strips having opening 50 mm x 100 mm approx; designed to construct working platform at top stage, FOH catwalk and other relevant areas to suit as per the site condition.

Refer supporting leaflet or image and technical specifications No-3.

Mode of measurement and payment- Measurement and payment will be for complete one set comprising of all components as stated in above and BOQ

SKETCH NO-3

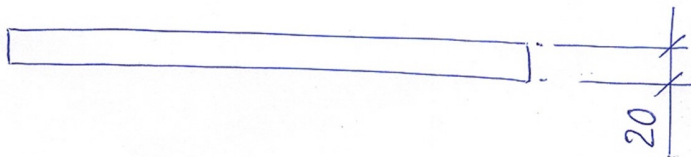
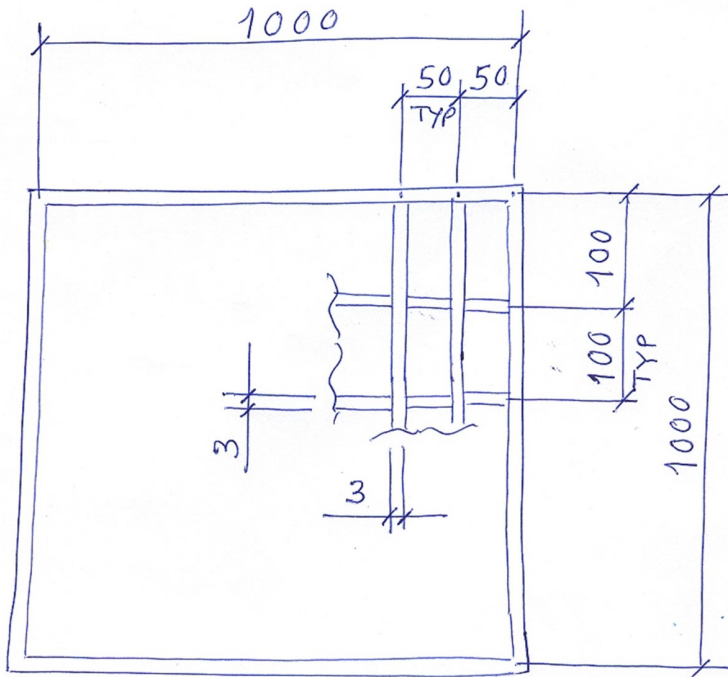

M.S. GRATING
(TYPICAL MODULE)

(WELDED CONSTRUCTION)

TECHNICAL SPECIFICATION FOR CABLE TRAYS (USOR-2023)

SCOPE

This specification covers the design, manufacture, testing at works, inspection and delivery at site of cable trays.

GENERAL

It is proposed that cables to be laid in the auditorium, control room, above false ceiling and on the walls of the auditorium will be laid on suitable cable trays. The entire requirement of this tender will be perforated type cable trays.

CONSTRUCTIONAL FEATURES

Material

The cable trays are to be manufactured from 2mm thick cold rolled sheet steel. The same shall be shaped and cut using power driven dies/ cutters/ presses to the specified sizes to form a standard length of cable tray and its accessories.

Finishing

The manufactured trays and all the accessories should undergo seven tank treatments and should be hot-dip galvanized as per BS-2629. The zinc coating of 60 microns has to be uniformly guaranteed. The trays will be tested for this at site at random and the contractor should make available at site Alcometer (or approved equivalent meter) for carrying out the test at site. The owners reserve the right to at random inspect the trays being manufactured at the manufactures factory.

The width of the cable trays is specified in the schedule of quantities. The other details will be as shown in the drawings. GI coupler plates with GI Jointing hardware is to be included in the rates of the contractor.

The following accessories are also to be supplied and installed by the contractor and the cost of the same is to be included in the rates for straight lengths to be quoted in the schedule of quantities. Couple plates and hardware (as stated above), Vertical elbow up, Reducer, Horizontal Tee, Horizontal Cross Piece, Horizontal Elbow, Vertical Elbow Down etc...

Providing cold galvanized paint touch up at site wherever trays, accessories and supports are cut/ drilled after hot dip galvanizing.

Bends

The trays should have radius so as to enable a bending radius of 12 x Dia. of largest cable to be laid in the tray.

Supporting Steel Work For Trays

Supporting structural steel members to be made from 50mm x 50mm x 6mm M.S. angles, 50mm x 6mm M.S. flats for trays of width 600mm & above and 40mm x 40mm x 6mm M.S. angles, 40mm x 6mm M.S. flats for trays of width less than 600mm and M.S. channels duly hot dip galvanized. In general on horizontal runs cable trays of width > 600mm & above will be supported at every 1 Mtr. And trays of smaller width be supported at 1.2 Mtr intervals. In vertical runs the trays should be supported at every 1 Mtr interval. Every horizontal bend will also be given an extra support.

Measurement

The installed trays and accessories will be measured at the central axis of the tray and bends. Bends,

reducers, elbows, coupler plates, hardware & steel supports will not be measured separately.

Well engineered, designed and manufactured of GI hot dip galvanized Suspenders cum clamps (bolttable and weldable) as per design and fabricated to suit as per site condition. GI hot dip galvanised angles ISA 50mm x 50mm x 6mm thk. to suit the site condition for supports etc including MS zinc plated fastners.

Dia M8 GI threaded rod of upto 1 mtr length with sliding rhombique nuts, locking nuts, washers etc. Refer supporting leaflet and technical specifications No-6 & 7.

Mode of measurement and payment- Measurement and payment will be for complete one set comprising of all components as stated in above and BOQ

PVC CONDUITS

All non-metallic conduit pipes and accessories shall be of suitable material complying with IS: 2509-1973 and 18:3419-1989 for rigid conduits and IS: 9537 (Part 5) 2000 for flexible conduits. The interior of the con 46 Conduits shall be free from obstructions. The rigid conduit pipes shall be ISI marked.

The conduits shall be circular in cross-section. The conduits shall be designated by their nominal outside diameter. The dimensional details of rigid non-metallic conduits are given in Table-II.

No non-metallic conduit less than 25mm in diameter shall be used. Wiring capacity

The maximum number of PVC insulated aluminum/copper conductor cables of 650/1100V grade conforming to IS: 694-1990 that can be drawn in one conduit of various sizes is given in Table-I. Conduit sizes shall be selected accordingly.

Conduit accessories

- i. The conduit wiring system shall be complete in all respect including accessories.
- ii. Rigid conduit accessories shall be normally of grip type.
- iii. Flexible conduit accessories shall be of threaded type.
- iv. Bends, couplers etc. shall be solid type in recessed type of works, and may be solid or inspection type as required, in surface type of works.
- v. Saddles for fixing conduits shall be heavy gauge non-metallic type with base.
- vi. The minimum width and the thickness of the ordinary clips or girder clips shall be as per Table III.
- vii. For all sizes of conduit, die size of clamping rod shall be 4.5 mm (7 SWG) diameter.

TABLE I

Maximum number of PVC insulated 650/1100 V grade aluminium / copper Conductor cable conforming to IS: 694-1990.

| Nominal cross Sectional Area of Conductor in sq.mm | 20mm | | 25mm | | 32mm | | 38mm | | 51mm | | 64mm | |
|--|------|---|------|---|------|----|------|---|------|----|------|----|
| | S | B | S | B | S | B | S | B | S | B | S | B |
| | 1 | 2 | 3 | 4 | 5 | 6 | 7 | 8 | 9 | 10 | 11 | 12 |
| 1.50 | 5 | 4 | 10 | 8 | 18 | 12 | | | | | | |
| 2.50 | 5 | 3 | 8 | 6 | 12 | 10 | | | | | | |
| 4 | 3 | 2 | 6 | 5 | 10 | 8 | | | | | | |
| 6 | 2 | - | 5 | 4 | 8 | 7 | | | | | | |

| | | | | | | | | | | | | |
|----|---|---|---|---|---|---|---|---|---|---|---|---|
| 10 | 2 | - | 4 | 3 | 6 | 5 | 8 | 6 | - | - | - | - |
| 16 | - | - | 2 | 2 | 3 | 3 | 6 | 5 | 1 | 7 | 1 | 8 |
| 25 | - | - | - | - | 3 | 2 | 5 | 3 | 8 | 6 | 9 | 7 |
| 35 | | | | | | | 3 | 2 | 6 | 5 | 8 | 6 |
| 50 | | | | | | | | | 5 | 3 | 6 | 5 |
| 70 | | | | | | | | | 4 | 3 | 5 | 4 |

Note:

1. The above table shows the maximum capacity of conduits for a simultaneous drawing in of cables.
2. The columns headed 'S' apply to runs of conduits which have distance not exceeding 4.25 m between draw in boxes and which do not deflect from the straight by an angle of more than 15 degrees. The columns headed 'B' apply to runs of conduit, which deflect from the straight by an angle of more than 15 degrees.
3. Conduit sizes are the nominal external diameters.

Ordinary Clips or girder clips

| Size of Conduit | Width | Thickness |
|-----------------|-------|--------------------|
| 1) 20mm & 25mm | 19 mm | 20 SWG (0.9144 mm) |
| 2) 32mm & above | 25 mm | 18 SWG (1.219 mm) |

DISTRIBUTION BOARDS (DLDB, GLDB)

TPN sheet steel, double door, vertical type, MCB distribution board 415 V on surface/ recess complete with tinned copper busbar neutral busbar earth bar dinnbar detachable gland plate interconnections phosphotized and powder painted including earthing etc. as required and interconnection between incomer MCB and busbars

Distribution boards shall be housed in purpose made metal cases conforming to relevant Indian standards. The distribution boards shall not be mounted at a height exceeding 180 cm from finished level.

Distribution Boards shall be equipped with rigidly fixed miniature circuit breakers complying with specific number of relevant code in the phase leads with over-load and short circuit protection. The miniature breakers shall have adequately sized terminals for the outgoing leads. Distribution boards shall have adequately sized terminals or clamps for the incoming conductors. Distribution boards shall have an earth bus bar with the necessary number of terminals for connecting the earth continuity conductors associated with the various circuits supplied from the board.

Each Distribution Board shall have a circuit schedule pasted or otherwise permanently fixed inside the cover stating the designation and details of the circuits controlled, and rating of miniature breakers. Non-flammable insulating barriers shall be provided between poles and phases and all live parts protected with non-flammable insulating shields to prevent accidental contact while operating the miniature breaker.

MINIATURE CIRCUIT BREAKERS (MCB)

MCBs shall be hand operated, air break, quick make, quick break type conforming to applicable standards.

The MCB shall be provided with overload/short-circuit protective device for protection under overload and short-circuit conditions. The switch action shall be trip free to inhibit closing under fault conditions. All brass parts shall be electroplated and all steel parts cadmium plated and all contacts silver plated. The minimum breaking capacity of MCBs shall be 10 kA rms. at 415V/220V D.C. MCBs shall be provided with locking facility.

Miniature circuit breakers shall be SP, DP, TP or 4P and of the current rating all as specified elsewhere or

approved. Each miniature circuit breaker shall be provided with spring-washer at each cable termination. All breakers shall be in accordance with the relevant standards.

The instantaneous magnetic tripping of the MCBs shall be in accordance with the latest edition of the I.E. Regulations. The magnetic tripping of miniature circuit breaker supplying socket outlets shall be 2.7 to 4 times their rated current. The magnetic tripping of the miniature circuit breakers supplying lighting circuits shall be 7 to 10 times their rated current.

Pre wired fluorescent / compact fluorescent fittings of all types complete with all accessories and tube etc. including supplying and fixing ball and socket arrangement 2 nos down rods of 20 mm dia x 1.6 mm thick steel conduit upto 30cm length painting the down rods and connections with 1.5 sq mm FR PVC insulated copper conductor single core cable and earthing etc as required.

LIGHTING FITTING AND ACCESSORIES SCOPE

This specification covers the design, material specification, manufacture, testing, inspection and delivery to site and installation & commissioning of lighting fittings and their associated accessories.

STANDARDS

The lighting fittings and their associated accessories such as lamps/tubes, reflectors, housings, ballasts, etc. shall comply with the latest applicable standards as specified. Where no standards are available, the supply items shall be backed by test results, shall be of good quality and workmanship & any supply items which are bought out by the Specialist Sub-contractor/Contractor shall be procured from approved manufacturers acceptable to the Employer/Engineer.

LIGHTING FITTINGS - GENERAL REQUIREMENTS

Fittings shall be designed for continuous trouble free operation under atmospheric conditions as specified without reduction in lamp life or without deterioration of materials and internal wiring. Outdoor fittings shall be weather- proof and rain-proof type.

The fittings shall be designed so as to facilitate easy maintenance, including cleaning, replacement of lamps/starters etc.

Connections between different components shall be made in such a way that they will not work loose by small vibration.

For each type of lighting fitting the Specialist Sub-contractor/Contractor shall supply the utilization factor to indicate the proportion of the light emitted by the bare lamps which falls on the working plane.

All fittings shall be supplied complete with lamps suitable for operation on a supply voltage and the variation in supply voltage. The supply shall include the body of the fixture, the globe or the diffuser, the lamp, lamp holder, the control gear and the fixing or suspension equipment.

The fittings and accessories shall be suitable for low temperature rise. The temperature rise above the ambient temperature shall be as indicated in the relevant standards. The material of the interior wiring of the fixture shall be adequately protected against the heat emitted by the lamps and gear.

All fluorescent lamp fittings shall be complete with all accessories like ballasts, power factor improvement capacitors, lamps, starters and capacitors for correction of stroboscopic effect.

Each fitting shall have a terminal block suitable for loop-in, loop-out and T-off connection by 250/415V, 1 core, PVC insulated Cu conductor cable of 4 sq.mm in size unless otherwise specified. In hazardous areas the termination at the fittings shall be suitable for 1100V, PVC, armoured cables of sizes specified and

terminals shall be of stud or clamp type. The internal wiring should be completed by the manufacturer by means of stranded copper wire and terminated on the terminal block.

The mounting facility and conduit knock-outs for the fixtures shall be as specified.

All hardware used in the luminaries shall be suitably plated or anodized and passivated for use in chemical industrial and power plants.

FIXING

Lighting fixtures shall be fixed in a workman like manner, strictly in accordance with the printed instructions of the manufacturer. All light fixtures in a row shall be in the same line and level and at exactly equal distance unless otherwise required. Care shall be taken that no light is emitted in upward direction, unless otherwise required, from recessed light fixtures.

MAKE

Light Fixtures shall be of the makes as specified in the list of approved makes. Supply of light fixtures shall include the supply of lamps and accessories complete with devices like angles, tees, hangers, flexible conduits, etc.

MOUNTING AND WIRING

Mounting shall include supply and fixing of conduit down rods, ball and socket, fixing device for recessed light fixtures etc. as required. Wiring shall include supply of wires from the outlet provided in the wall/ceiling, connectors and other necessary hardware.

EARTHING

Each lighting fitting shall be provided with an earthing terminal suitable for connection to the earthing conductor.

All metal or metal enclosed parts of the housing shall be bounded and connected to the earthing terminal so as to ensure satisfactory earthing continuity throughout the fixture.

PAINTING/FINISH

All surfaces of the fittings shall be thoroughly cleaned and degreased. The fittings shall be free from scale, rust, sharp edges and burrs.

When enamel finish is specified, it shall have a minimum thickness of 2 mils for outside surface and 1.5 mills for inside surface. The finish shall be non-porous and free from blemishes, blisters and fading.

The housing shall be stove-enameled/epoxy stove-enameled-vitreous enameled or anodized as indicated on flame- proof fittings is prohibited.

The surface shall be scratch resistant and shall show no sign of cracking or flaking when bent through 90o over ½" dia mandrel.

The finish of the fittings shall be such that no bright spots are produced either by direct light source or by reflection.

FLUORESCENT LAMP/CFL FITTINGS

For general industrial use in humid atmosphere, the fittings shall be provided with CRCA sheet steel mounting/housing channel vitreous enameled and with vitreous enameled reflector of minimum 20 SWG thickness.

For dusty and vapor prevalent atmosphere, the fittings shall be dust and drip proof type, totally enclosed in

sheet steel housing with a heat resistant toughened glass cover or clear acrylic sheet. The housing shall be epoxy stove-enameled and neoprene gaskets shall be provided for sealing.

For atmosphere where chemical vapours/fumes are corrosive, the material of fitting housing/mounting, reflectors and end-plates shall be of cast aluminum/aluminium sheet and finished in epoxy stove enamel to resist corrosion. Control gear housings, starters and tube holder assemblies shall be provided with neoprene gaskets to make it proof against entry of corrosive vapors.

Fittings shall be suitable for the number of lamps of specified wattage, for directly mounting on ceiling/wall and or conduit suspended.

ACCESSORIES FOR LIGHTING FITTINGS REFLECTORS

The thickness of steel/aluminum shall comply with relevant standards specified. Reflectors made of steel shall have stove enameled/vitreous enameled/epoxy coating finish. Aluminium used for reflectors shall be anodized/epoxy stove enamelled/mirror polished. The finish for the reflector shall be as indicated for above mentioned fittings.

Aluminium paint on the reflectors of flame-proof lighting fittings is prohibited. Reflectors shall be free from scratches or blisters and shall have a smooth and glossy surface having an optimum light reflection coefficient such as to ensure the overall light output specified by the MANUFACTURER.

Reflectors shall be readily removable from the housing for cleaning and maintenance without disturbing the lamps and without the use of tools. They shall be securely fixed to the housing by means of positive fastening device of captive type.

LAMP/STARTER HOLDERS

Lamp holders shall comply with relevant Indian standards. They shall have low contact resistance, shall be resistant to wear and shall be suitable for operation at the specified temperature without deterioration in insulation value. They shall hold the lamps in position under normal condition of shock and vibration met with in normal installation and use.

Lamp holders for the fluorescent lamps shall be of the spring loaded bi-pin rotor type. Live parts of the lamp holder shall not be exposed during insertion or removal of the lamp or after the lamp has been taken out. The lamp holder contacts shall provide adequate pressure on the lamp cap pins when the lamp is in working position.

Lamp holders for incandescent and mercury vapour lamps shall be of bayonet type upto 100W and Edison Screw type for higher Wattage lamps.

Starter holders for fluorescent lamps shall conform to the standards specified. All material used in the construction of the holder shall be suitable for tropical use.

The starter holders shall be so designed that they are mechanically robust and free from any operational difficulties. They shall be capable of withstanding the shocks met within normal transit, installation and use.

BALLASTS

The ballasts shall be designed, manufactured and supplied in accordance with the relevant standards. The ballasts shall be designed to have a long service life and low power loss.

Ballasts shall be mounted using self locking, anti-vibration fixings and shall be easy to remove without demounting the fittings. They shall be in dusting, non-combustible enclosures.

Inductive ballasts shall be open construction low watt loss insulating, moisture under pressure or vacuum. Ballasts shall be provided with tappings to set the voltage within the range specified. End connections and taps shall be brought out in a suitable terminal block, rigidly fixed to the ballast enclosure. The ballast wiring shall be of copper wire. They shall be free from hum. Ballasts which produce humming sound shall be replaced free of cost by the Specialist Sub-contractor/Contractor.

Electronic ballasts shall conform to all EN & IEC specifications with THD less than 10% and 3rd harmonic below 6.5% with constant output & constant wattage. Electronic ballast shall be able to withstand voltage surges upto 320V. Ballast shall be common for both 36W FTL & CFL lamps power factor shall be close to unity. Total system consumption for 2 x 36 W FTL must not exceed 70W.

Separate ballast for each lamp shall be provided in case of multi-lamp fittings, except in the case of 2 x 20 watts fittings.

STARTERS

Starters shall have bimetal electrodes and high mechanical strength. Starters shall be replaceable without disturbing the reflector or lamps and without the use of any tool. Starters shall have brass contacts and radio interference capacitor.

The starters shall generally conform to the relevant standards.

CAPACITORS

The capacitors shall have a constant value of capacitance and shall be connected across the supply of individual lamp circuits.

The capacitors shall be suitable for operation at supply voltage and shall have a value of capacitance so as to correct the power factor of its corresponding lamp circuit to the extent of 0.95 lag or better.

The capacitors shall be hermetically sealed preferably in a metal enclosure to prevent seepage of impregnate and ingress of moisture.

LAMPS

The fluorescent lamps shall be 'Day-light colour' type unless otherwise specified and shall be provided with features to avoid blackening of lamp ends. 20/40W tube lamps shall be of high efficiency similar to Philips Trulite or equivalent.

The constructional features of gas discharge lamps for special applications or for instant start fluorescent lamps if specified shall be clearly brought out in the bid.

The lamps shall be capable of withstanding small vibrations and the connections at lead in wires and filaments/electrodes shall not break under such circumstances.

Lamps/tubes shall conform to relevant Indian standards and shall be suitable for supply voltage and frequency specified.

TESTS AND TEST REPORTS

Type tests, acceptance tests and routine tests for the lighting fittings and accessories covered by this specification shall be carried out as per the relevant standard for the respective fittings and their accessories.

The manufacturer's type and routine test certificates shall be submitted for tests conducted as per relevant Indian standards for the fittings and accessories. The Contractor shall submit with his proposal copies of

available test certificates of the fittings offered.

JUNCTION BOXES (CMB24, CMB32, IMB12, IMB4, IMB6, AMB12+8, AMB4+4, DMX-OUT, DMX-IN, DMX-WB, EM-TRIP, CEE3, CEE1, IEC4, APJB, DLJB, GLJB, DLDB, GLDB, PCJB)

Marshalling boxes

Well engineered, designed and manufactured of MS cable termination power marshalling boxes made of 2 & 1.5 mm thick CRCA sheet, along with fixing arrangement, powder coated 60 microns black matt finish with proper chemical treatment and methodology. Along with clip on type terminals with DMX 5 pin XLR male female sockets, mushroom head stay put type push buttons mounting accessories, terminal marking labels, required brass cable glands, neoprene dust and vermin proof rubber gaskets, hinged inspection door, name plates, MS hardware duly zinc plated etc. Junction boxes with terminals shall be supplied for branching and terminating lighting cables required for stage lighting etc. Refer supporting leaflet or images and technical specifications

Mode of measurement and payment- Measurement and payment will be for complete one set comprising of all components as stated in above and BOQ

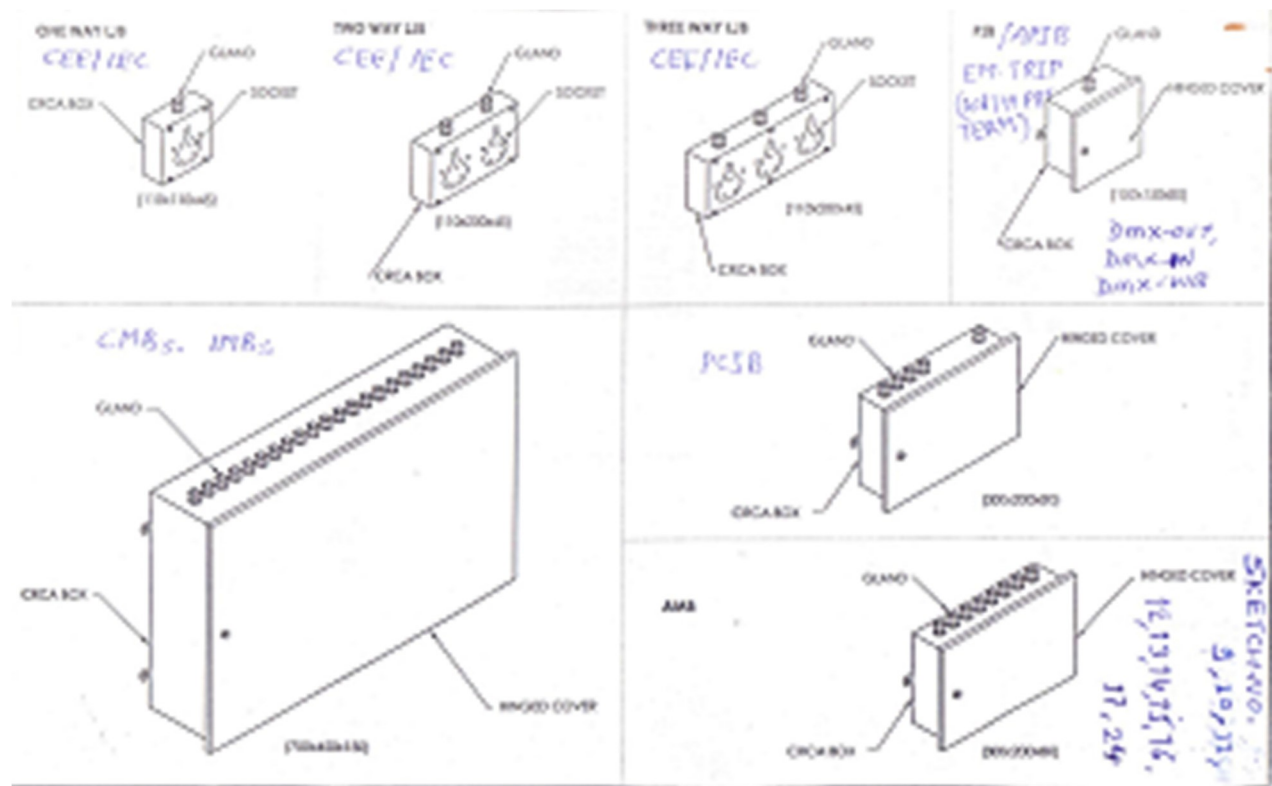

Feeder (MCCP-1) motor control

Well engineered, designed and manufactured of Compact wall mount **11 feeder (MCCP-1) motor control** centre panel arrangement made out of 2 mm thick CRCA sheet with necessary mounting frame to control the motorized lighting bars, powder coated 60 microns black matt finish with proper chemical treatment and methodology. Including 1 No. 16A TPN MCB, 8 Nos. feeders consisting fuses, contactors, overload relays, emergency tripping system, step down transformer, cu. bus bars, indicating lamps, completely wired, clip on type terminals with mounting accessories, terminal marking labels, required brass cable glands, neoprene dust and vermin proof rubber gaskets, bolted inspection cover, name plates, MS hardware duly zinc plated etc. Refer supporting leaflet and technical specifications

Mode of measurement and payment- Measurement and payment will be for complete one set comprising of all components as stated in above and BOQ

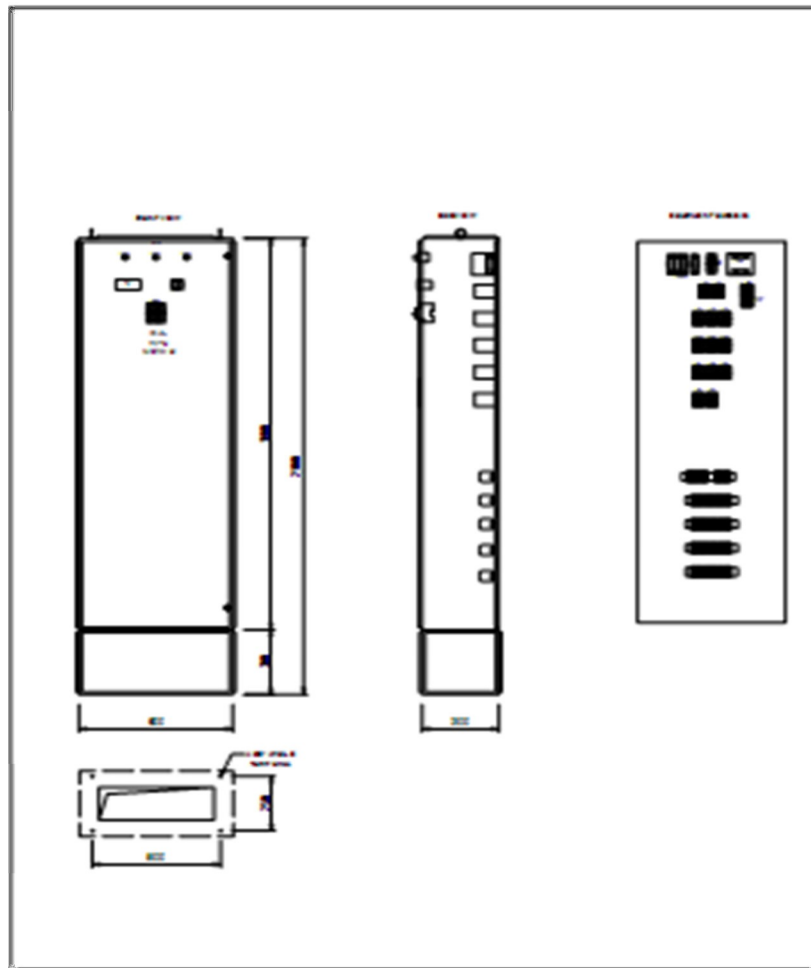

Compact wall mount 11 feeder

Well engineered, designed and manufactured of **Compact wall mount 11 feeder (RCP-1)** remote control panel arrangement made out of 2 mm thick CRCA sheet with necessary mounting frame to control the motorized lighting bars, powder coated 60 microns black matt finish with proper chemical treatment and methodology. Including 8 Nos. selector switches, 1 No. up/down mode selector switch, 3 Nos. indicating lamps, completely wired, clip on type terminals with mounting accessories, terminal marking lables, required brass cable glands, neoprine dust and verminproof rubber gaskets, bolted inspection cover, name plates, MS hardware duly zinc plated etc.

Refer supporting leaflet and technical specifications

Mode of measurement and payment- Measurement and payment will be for complete one set comprising of all components as stated in above and BOQ

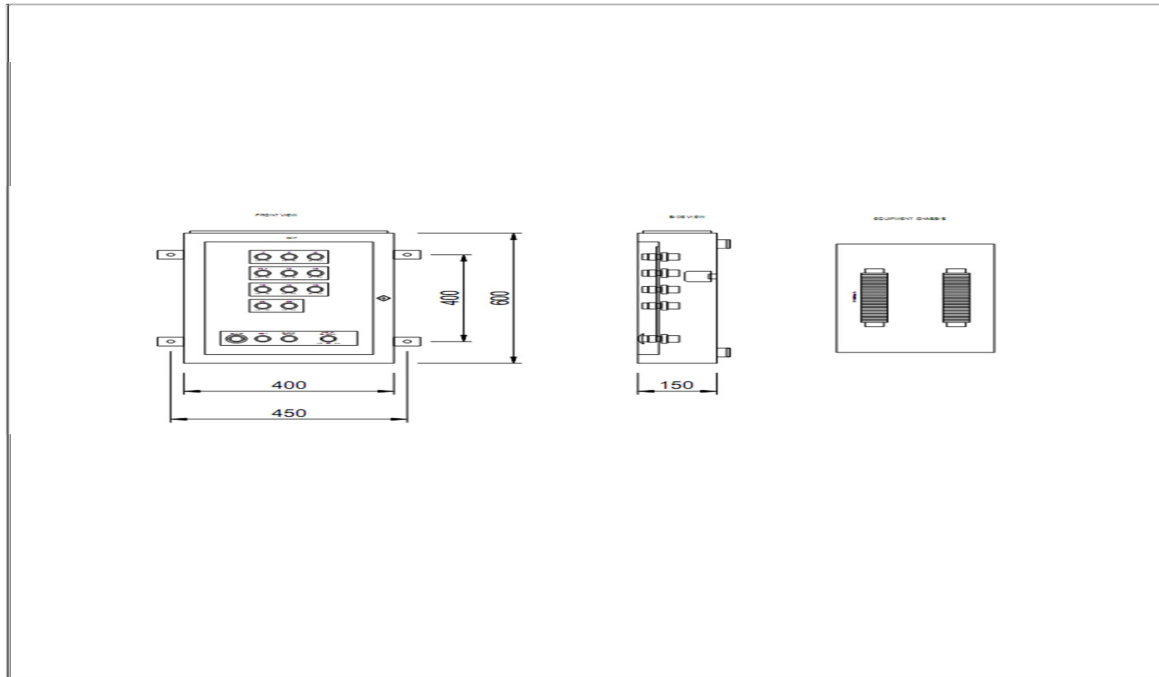

Well engineered, designed and manufactured, MS sheet metal dust and vermin proof 2.5mm, 2.0mm and 1.6mm thk. fabricated floor standing with pedestal 19" Din rack comprising mechanically and electrically interconnected three cubicles of 600 x 600 x 1800, 42U, with pedestal, hinged doors, bolted side covers, canopy and removable gland plates for PDCP, DIMMER Packs, MCPB , DMX Splitter and Metering etc. (as listed below) duly internally wired consisting of terminals, brass cable glands, rubber gaskets and name plate etc. Duly zinc plated and powder coated 60 microns black matt finish with proper chemical treatment and methodology.

Refer supporting leaflet and technical specifications No-19. with single line diagram / scheme.

Mode of measurement and payment- Measurement and payment will be for complete one set comprising of all components as stated in above and BOQ

Channel x 2.5 KW dimmer pack with necessary wiring 5 Nos as per single line diagram

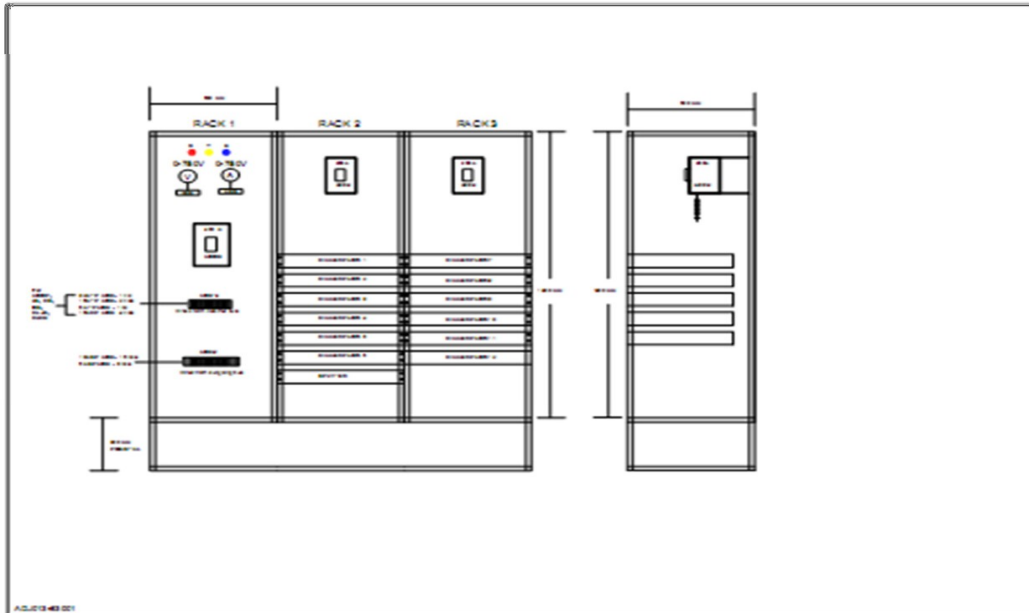

Grid mount photo isolator **DMX splitter unit** 1 DMX input and 8 isolated output.

It should have DMX input and 8 isolated output. Should be operating on AC 90-240V, 45-63Hz power supply. It should be DMX 512 Protocol control. Control signal input should be 1 pcs 5 pin XLR female. It should be suitable for mounting in 19" 1U standard rack.

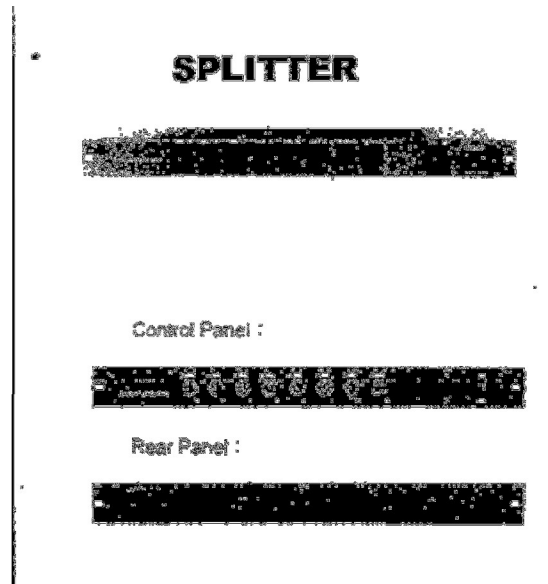

Programmable digital lighting console 200 dimmer channel & 30 fixture with 24fader, 10 faders x 20 pages.

It should offer a control of 200 dimmer channels from a numeric keypad using industry standard command syntax. Upto 30 fixtures should be controlled using fixture select buttons and three control wheels. The on board LCD screens should provide the user with all information needed to operate the console allowing it to be used without a monitor. It should have monitor port, keyboard support and USB port. The console should be capable of operating in preset, program or playback mode.

Lighting console should comply following specifications:

- a. Dimmer channels: 200.
- b. Groups: 30.
- c. Fixtures: 30.
- d. Macros: 30.
- e. Colour/ Beamshape/ Position palettes: 30 each.
- f. Fixture/ Palette select buttons: 3 pages of 10.
- g. Fixture control wheels: 3.
- h. Total control channels: Upto 512.
- i. Play back master fader: 1.
- j. Submaster faders: 10.
- k. Submaster multi function buttons: 24.
- l. Submaster pages: 20.
- m. Grand Master fader: 1.
- n. Blackout button: 1.

- o. Power supply: External 100-240 Volts 50/60Hz.
- p. DMX output: 1 Inverse USITT DMX512-A.
- q. DMX input: 1 Universe USITT DMX512-A.
- r. Operating temperature: +5°C to +40°C.

ELECTRICAL PANELS AND DISTRIBUTION BOARDS

The specifications are given below to enable the design, manufacture and supply of the Electrical panel boards appearing in the schedule of quantities. The scope of work will also include transporting these panels to project site, storing, handling, shifting, installing, testing and commissioning them.

Panel Boards which are free floor standing should be erected on suitable hot dip galvanized M.S. Channels. These shall be erected across cable trench, if the cable entry to the panel is from below and readymade cable trenches exist. Panels which are to be wall mounted should be erected on a hot dip galvanized M.S. frame. All mountings in flooring / wall etc. should be using anchor fasteners and G.I. hardware.

APPLICABLE STANDARDS:

The design, manufacturing process and performance of the L.T. electrical panel boards and all the equipment & instruments incorporated in the same shall comply with the latest Indian Standards set by B.I.S. and particularly to the following :

| BRIEF DESCRIPTION | REFERENCE STAND |
|---|--------------------|
| Switch gear General Requirements | IS : 4237 |
| Factory Built Assemblies of Switch gear and Control gear and bus trunking | IS : 8623 |
| Miniature Circuit Breaker | IS : 8828 |
| HRC Cartridge fuse | IS : 9224 (Part 2) |
| Current Transformers | IS : 2705 |
| Indicating Instruments | IS : 1248 |
| Busbar Connections and Accessories | IS : 5578, 11353 |
| Code of Practice for Phosphating Iron & Steel | IS : 6005 |
| PVC Wires | IS : 694 |

The above are minimum standards expected. The technical specifications to follow and those given in schedule of quantities, if found to be more stringent as compared to those listed above, then the more stringent specifications shall prevail.

SHEET METAL WORK:

The panel boards frame shall be fabricated using suitable mild steel structural sections or pressed and shaped cold rolled sheet steel of thickness not less than 2.5 mm.

Frames shall be enclosed by cold rolled sheet steel of thickness not less than 2.0 mm. smoothly finished,

leveled and free from flaws. Doors and covers shall be made of cold rolled sheet steel of thickness not less than 1.6 mm. Stiffeners shall be provided wherever necessary.

All panel edges and door edges shall be reinforced against distortion by rolling, bending or by the addition of welded reinforced members. Cut-outs shall be true in shape and devoid of sharp edges. The complete structure shall be rigid, self-supporting and free from vibration, twists and bends.

PAINTING:

All sheet steel work shall be powder coated using the seven tank process and in accordance with applicable standards mentioned above.

CONSTRUCTIONAL FEATURES:

Switch gear shall be:

- a) Indoor, floor mounted modular type (wall mounted wherever so specified in schedule of quantities);
- b) Of vermin proof construction;
- c) Provided with a degree of protection of Ingress Protection (IP) 52;
- d) Provided with a metal sill frame made of structural steel channel section properly drilled for mounting the switch gear along with necessary mounting hardware (hardware shall be zinc plated and passivated);
- e) Provided with neoprene gaskets all round the perimeter of removable covers and doors; and
- f) Provided with busbar of adequate rating.

No equipment needing manual operation shall be located less than 250 mm above ground level and also not more than 1800 mm above ground level

Cable alleys shall be provided with suitably hinged doors/cover. It shall be possible to safely carry out maintenance work on cable connections to any one circuit with the busbar and adjacent circuits live. Adequate number of slotted cable support arms shall be provided for cleaning the cables.

BUSBARS:

Switch gear shall be provided with three phase and neutral busbar. Busbar shall be of uniform cross section throughout their length and upto the incoming terminals of the incoming feeder circuit breaker.

The busbar shall be made of high conductivity Aluminium and shall be provided with at-least the minimum clearances in air as per applicable standards for a 500 V, 3 phase system.

All busbar and bus-taps shall be insulated with close fitting sleeve of hard, smooth, dust & dirt free plastic insulation of high dielectric strength (450 V/mil) to provide a permanent high dielectric non-aging and non-tracking protection; impervious to water, tropical conditions & fungi. The insulation shall be non-inflammable and self-extinguishing and in fast colours to indicate phases. The joints shall be insulated in such a way as to provide for accessibility of contact bolts for maintenance. The dielectric strength and properties shall hold good for the temperature upto 900 C.

Busbar shall be adequately supported and braced to withstand the stresses due to the specified short circuit currents. Bus bar supports shall be made of Hylam sheets, glass reinforced moulded plastic material, Permali wood or cast resin.

Separate supports shall be provided for each phase of the busbars. If a common support is provided for all three phases, antitracking barriers shall be incorporated.

Busbar joints shall be complete with high tensile steel bolts and Belleville washers and nuts. Busbars shall be thoroughly cleaned at the joint locations and suitable contact grease shall be applied just before making a joint.

The manufacturer of panel boards shall have 50 Kmp short circuit withstand certification from Central Power Research Institute (C.P.R.I.)

FUSES:

Wherever, fuses have been specified in the BOQ / SLD, these shall be of the HRC cartridge fuse-link type having a certified rupturing capacity of not less than 80 kA at 440 V. Fuses shall be provided with visible indication to show that they have blown.

MOULDED CASE CIRCUIT BREAKERS:

The MCCB's shall comprise single units of triple pole construction and shall be rated for 500 VAC.

All live parts shall be totally enclosed in a heat resistant moulded insulating material housing. Operating mechanism shall be quick make, quick break and trip free type.

The MCCB's shall be provided with the following features:

- a) Inverse-time-current tripping characteristics under sustained overload.
- b) Instantaneous tripping on short circuit.
- c) Door interlock.
- d) Release mechanism shall be microprocessed based for current rating of 250 amps and above and thermal magnetic for rating below 250 amps

MINIATURE CIRCUIT BREAKER (MCB):

Miniature circuit breaker shall have minimum short circuit breaking capacity as indicated in the single line diagrams or schedule of quantities. If breaking capacity is not specified then it should not be less than 10 kA.

CURRENT TRANSFORMERS:

Current transformers shall be of the resin impregnated type.

All current transformers shall be earthed through a separate earth link.

INDICATING INSTRUMENTS AND METERS:

Digital meters should have red coloured readout of minimum 25 mm. They shall be of 96 mm square size and class of accuracy 1.0

CABLE TERMINATIONS:

Suitable Double Compression Type, brass cable glands with check nuts, rubber sealing ring and brass washers mounted on a removable gland plate shall be provided to support all cables entering the switchgear. Cable Termination will be measured under separate item in the schedule of quantities.

INTERNAL WIRING:

Wiring inside the switchgear shall be carried out with 1100 V grade, single core, PVC insulated, stranded copper conductor wires. Not more than two connections shall be made on any one terminal.

TERMINAL BLOCKS:

Terminal blocks shall comprise finely threaded pairs of brass studs of at least 6 mm diameter, links between each pair of studs, washers, nuts and locknuts. The studs shall be securely locked within the mounting base to prevent their turning. Insulated barriers shall be provided between adjacent terminals.

Terminals shall be shrouded. Terminal blocks shall be adequately rated to carry the current of the associated circuit. Minimum rating of the terminal block shall be 10 A.

LABELS:

All labels shall comprise white letters on a black background and shall be made of non-rusting metal or 3-ply lamincoid or engraved PVC. Size of lettering shall be 6.0 mm.

EARTHING:

Switchgear shall be provided with a 30 mm x 5 mm copper earth busbar running along the entire length of the board. At either end of the earth bus, one clamp type terminal with nuts, bolts and washers shall be provided for bolting the earthing conductor.

Earth busbars shall be supported at suitable intervals. Positive connection between all the frames of equipment mounted in the switchboard and earth busbar shall be provided by using insulated copper wires / bare busbars of cross section equal to that of the busbar or equal to half the size of circuit load current carrying conductor, whichever is smaller.

All metallic instrument cases shall be connected to the earth busbar using 1100 V grade, single core 2.5 sq.mm. stranded, copper earthing conductor.

CABLES:

General

All material shall conform to relevant standard as per BIS and shall carry ISI mark. If any particular category of material for which ISI mark is not available in market, it shall be as included in approved list.

Work shall be carried out as per the method of construction specified by BIS. If there is no reference for particular method of construction in IS, such work shall be carried out as per the approved method of construction specified in chapter 16 of P.W. Dept. Handbook.

Material and work not qualifying to any provision mentioned above shall be to the satisfaction of the Engineer-in-charge.

Cables : (Armoured)

The following list records those Indian Standards in force, which are acceptable as good practice and accepted standards.

| | | |
|----------------------------|---|--|
| SP 30 : 1984 | : | National Electrical Code |
| SP 7 (Group 4) : 2005 | : | National Building Code |
| IS 1255 : 1983 | : | Code of Practice installation & Maintenance of armoured cables up to 33 KV. |
| IS 3961 : Part 2 : 1967 | : | Recommended current ratings of PVC cables. |
| IS : 1554 : Part 1 : 1988: | | PVC Insulated (Heavy Duty) Electrical Cables; Part 1 for working voltages up to and including 1100 volts. |
| IS : 1554 : Part 2 : 1988: | | PVC Insulated (Heavy Duty) Electrical Cables; Part 1 for working voltages up to and including 3.3 KV to 11 KV. |
| IS 10810 : Part 63: 1993 | : | Method for Test of Cables, Part 63 Smoke density of electric cables under fire condition. |

Scope :

Specification No. (CB-LT/AL, CB-LT/ CU, CB-HT)

Providing armoured cable of specified voltage level, size & specified conducting material (Aluminium/ Copper) as per Table no. 7/3 including required material, hardware's for erection and erecting on wall, ceiling, RCC slab or drawing the same through pole, pipe, laying in provided conduit, trench, ducts trays as per approved method of construction including glands, lugs etc.

Material Cables :

Cables shall be PVC for LT/MP and XLPE for HT as per Table no. 7/3 and of required construction, colour, shall carry ISI mark, IS no, manufacturer's name, size, duly embossed / screen printed at every meter and having the total count of progressive length in meter at each mark.

- Earth Wire : Galvanized Iron (G I) wire of appropriate gauge as per Table No. 7/1.
- Glands : As per specification (CB-GL)
- Lugs : As per specification (CB-CL/AL, CB-CL/CU)
- Saddles : Saddles fabricated from GI sheet of required gauge and size depending on dia of cable either galvanized or painted with superior quality enamel black paint with necessary shearing mechanical strength, semi circular shaped with extended piece having suitable holes for fixing.
- G.I. Strip : 22g X 25 mm width G.I. Strip.
- Clamps : MS Clamps fabricated of required length and shape, having the size of 3/6 mm thk mild steel having 25/50 mm width (as per size of cable), rounded ends with wooden / resin cast grip for holding the cable.
- Identification Tags : For identifying root, connection position GI strip with identification mark / name embossed / painted with arrangement to tie should be fix on cable or arrangement of ferrules to be done.
- Hardware : Sheet Metal (SM) screws of required sizes, plugs / wooden gutties etc.

Method of Construction :

General :

- a) Irrespective of method of construction the cable ends shall be terminated with appropriate size & type of glands with lugs duly crimped as directed by Site Engineer.
- b) Wherever the cable has to be bent, the turning radius shall be as mentioned in table no. 7/2. Grouping of cables shall be done with adequate distance between cables as mentioned in IS so as to minimize de-rating. Cables shall be tagged / ferruled with identification name / mark at the point from where distribution starts and at ends. Bare earth wire of appropriate size as per Table no. 7/1 shall run along with the cable. Earth wire running with the cable shall be terminated at the earth terminal nearest to cable termination.

Erection of Cable on Surface :

Erection shall be done as per the routes and layout finalized. In perfect level & in Plumb. Before fixing the cable shall be straightened as far as possible for good aesthetics look,

continuous bare GI earth wire of required gauge as per Table no. 7/1 shall be run, Cable with GI wire shall be fixed by saddles firmly clipped on cable and shall be fixed to wall with minimum 50 x 8 mm SM screws with plugs / wooden gutties etc. (Distance between two supports / saddles shall be maximum 450 mm). Wooden gutties shall be used wherever required (Especially for stone wall). The entries made in wall, floor slab etc for laying the cable shall be made good by filling and finishing with plastering the same.

Erection of Cable on Trusses :

Cable along with bare GI Earth wire, while erecting on trusses, shall be firmly clamped by wrapping GI strip of 22 g 25 mm width of required length fixed to truss with nuts and bolts.

Erection of Cable on Pole :

Cable along with bare GI earth wire, while erecting on pole, shall be firmly clipped by suitable wooden / epoxy resin cast grips, clamped with 25 x 3 mm or 50 x 6 mm MS strip of required length and fixed to pole with nuts and bolts.

Laying of cable in provided Trench / Pole ;

While laying cable along with bare GI earth wire, utmost care shall be taken to prevent damage to the insulation of the cable and to the open end. Cable shall be brought out from trench vertically straight (minimum 1.0 metre above G.L.) Care shall be taken to inspect the trench so that depth of cables shall not be less than as shown in Table No. 7.4. Suitable size of cable loops shall be provided near termination point at adequate depth.

Erecting Cable in constructed Trench / Dust ;

Erection of cable/s constructed trench / duct, shall be as per guide lines of IS 1255.

Erection of Cable/s on Trays :

Cable/s shall be tied with PVC tags on GI trays. At bending point care shall be taken so that sharp edges of sheet will not damage insulation of cable.

Mode of Measurement :

Executed quantity shall be measured on the basis of running metre per run of cable.

Well engineered, designed and manufactured 16 channel and 8 channel Decoder to convert DMX signal from console to 0 - 10V DC control signal, grid mount made out of 2 mm CRCA sheet, powder coated 60 microns black matt finish with proper chemical treatment and methodology. overall size of box 400 X 250 X 150 mm approx.

Refer supporting leaflet or image and technical specifications No-25.

Mode of measurement and payment- Measurement and payment will be for complete one set comprising of all components as stated in above and BOQ

Supplying and drawing/fixing indoor type 2pair 0.5 sq.mm FR PVC insulated copper conductor unarmoured telephone cable ITD/DOT approved, with GI saddles on wall or in the existing surface/recessed steel/PVC conduit having following pair(s), complete as required.

Telephone wiring to be brought to a tag-block at a suitable point in ground floor. Provisions shall be kept for suitable entry-pipe for laying incoming telephone cable.

Unarmored Telephone Cable

Telephone cable should be solid annealed tinned electrolytic copper high conductivity conductor insulated and sheathed with PVC compound as per BS : 6746, unarmoured twisted pairs with proper colour code bundled together in concentric layers and wrapped with melinix or PVC tape with nylon ripcord. Ripcord is laid longitudinally under the sheath as an effective means of slitting the sheath to facilitate removal. The lay is chosen so as to minimize cross talk in cable. Manufactured to standard for indoor telephone wiring conductor resistance at 20 deg celcius max 98 ohms/Km, conductor diameter 0.5 mm.

Telephone Junction Boxes (20 & 10 pair)

Telecommunication distribution enclosure with Hi-technology connectors.

The Telephone tag blocks made of thermoplastic polyester as insulation and carrier material for the krone LSA plus contacts in weather resistant, dust & water proof, wall mounting lockable CRCA sheet, having

suitable back mount frames, jumpering facility, powder coated with required pair connectors and following technical specification:

Technical Specification of Modules

| | |
|-----------------------|---|
| Conductor dia | 0.40....0.80mm |
| Outside dia | 0.70....1.60mm |
| Conductor insulation | Plastic material pe or pvc |
| No.of wires/contact | 1 (2 wire only with conductor Dia 0.4 to 0.65mm) |
| Temperature operation | -20 + 80 deg.c |
| Relative humidity | 93% at + 40 deg.c |
| Contact type | Idc silver plated |
| Connection | Dry gas tight |
| No. of retermination | > 200 |
| Wire clamping & guide | Double sided |
| Vibration | Iec 50a (co) 145, (iec 68-2-g test fc) din 57804 |
| Contact resistance | <2.5m ohm |
| Insulation resistance | >50,000 mega ohms |
| Dielectric strength | 2 kv rms |
| Impulse voltage | >3.6 kv |
| Resistance | |
| Current impulse | >0.5 kv |
| Strength | |

Motorized Lighting Bar

Well engineered, designed and manufactured of Motorized lighting bar of length 14 mtrs dual barrel construction, having 12 nos 1 way 16 A CEE sockets for hot lights and 2 nos 4 ways 10A IEC sockets for cool lights on 150 wide cable trays and lids. (LB1, LB2, LB3, CYC LB) Comprising followings with proper surface finish

- a. * Necessary Sockets, cable trays and lids.
- b. Necessary pulley, guide pulleys Dia 100mm x 13mm thick with bearing and mounting brackets.
- c. Ø5mm GI wire ropes with winding drum for 7 falls to suit 16 metres travel.
- d. Specially designed compact gear box Al gear box ratio 80:1 with winding drum with hardware
- e. 1.5HP, 1000 RPM, 440 V, 3PH ISI marked AC motor with DC Brake
- f. Up and down limit controller PVC moulded box, lead screw, limit switches
- g. * Motor power and control cable termination box MS box with terminals, glands and gasket (PCJB).
- h. Foundation frame ISA 50mm x 50mm x 5thk for drive unit as per site condition

- i. 40NB dual pipe MS. 'B' class, powder coated 60 microns black mat
- j. MS Strip for jointing powder coated 60 microns black mat with proper chemical treatment.
- k. MS clamps (pair of press parts) per set
- l. M10 x 40mm MS zinc plzted hardware (bolts, nuts, washers)
- m. PVC moulded end caps for 40 NB pipe per set
- n. Power cables and signal from marshalling box to the sockets through cable retractors.
- o. Alumimium cable retractors of size 100mm x 40mm approx. of required length including built in cables.
- p. * Lighting cable termination box (AMB).

Refer supporting leaflet or image bellow and technical specifications No-27. * Items are covered in BOQ.

Mode of measurement and payment- Measurement and payment will be for complete one set comprising of all components as stated in above and BOQ

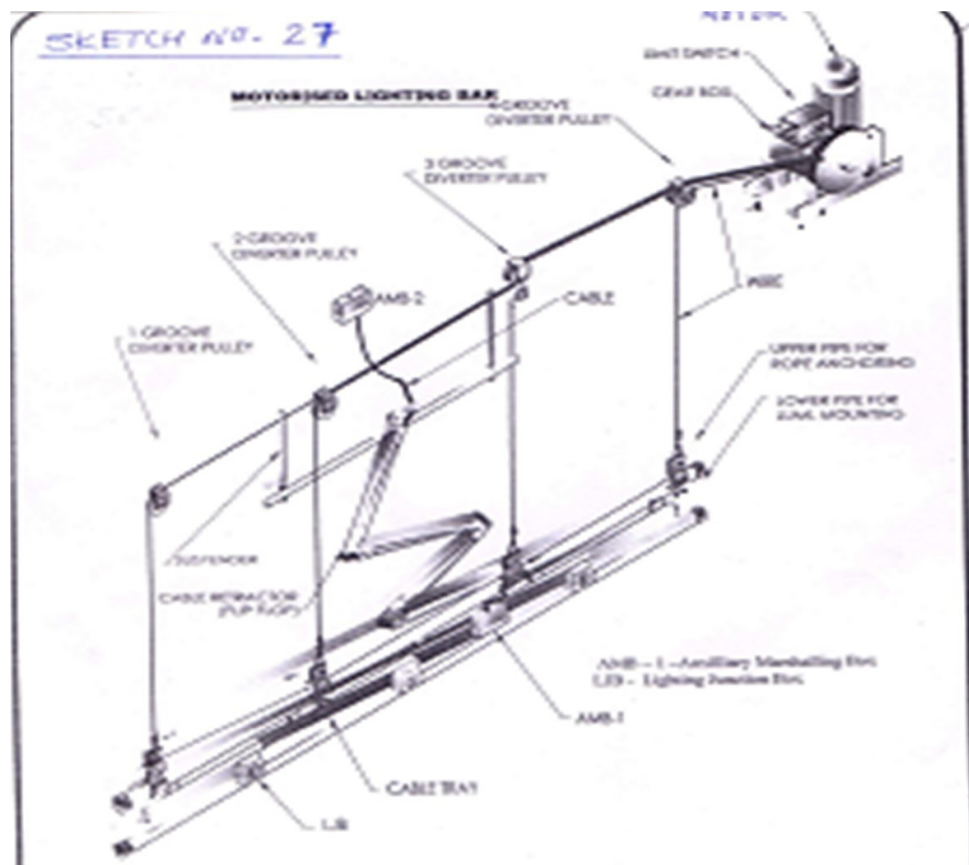

Motorized tele climber

Well engineered, designed and manufactured of self-climbing motorized tele climber hoists with compact gear box, 0.75HP, 440V, 1000 RPM motor with DC brake, extreme end limit controllers, necessary electro mechanical devices, 4nos 1 way 16amps CEE sockets for hot lights and 1 no. 4 ways, 10 A IEC sockets for

cool lights, cable retractor with necessary power and control cables and 3mtr long 40NB MS class B pipe provided with pair of suitable ladder (WTC)

Refer supporting leaflet or image bellow and technical specifications No-28.

Mode of measurement and payment- Measurement and payment will be for complete one set comprising of all components as stated in above and BOQ

Ladders for Teleclimber

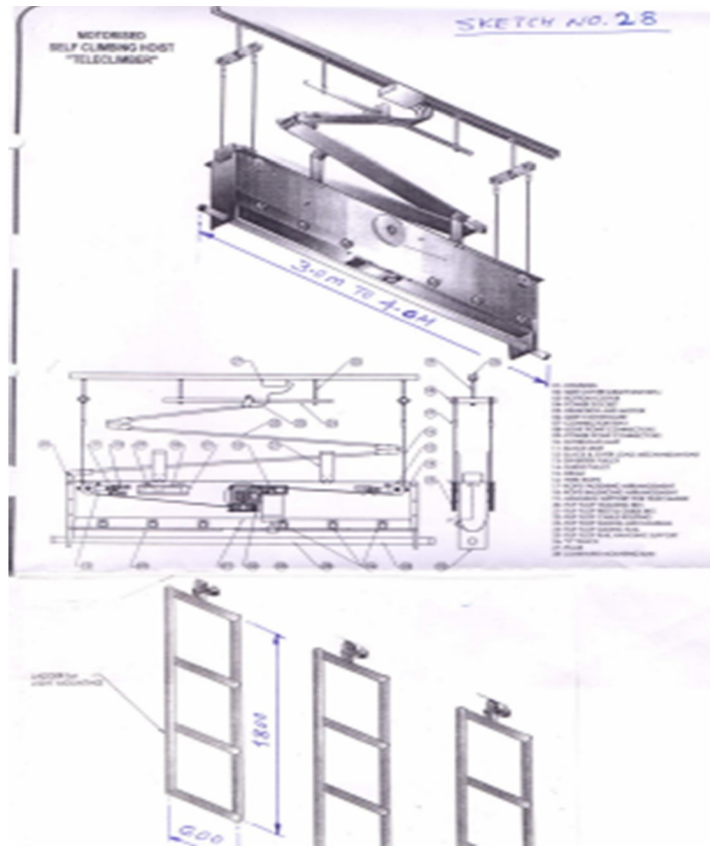

Fixed type lighting bar

Well engineered, designed and manufactured of Non-Motorized i.e. fixed type lighting bar 21 metres long (shipping section of each unit length 3 mtrs) dual barrel construction, having 18 nos 1 way 16 A CEE sockets for hot lights and 2 nos 4 ways 10A IEC sockets for cool lights on 150 wide cable trays and lids. (FOH-LBs) Comprising followings with proper surface finish

- a. * GI plate 6 mm thk. Hot dip galvanised with M12 hex nut welded
- b. * Suspenders of ISA 50mm x 50mm x 5thk as per site condition
- c. * MS M12 x 1M long with MS hardware nuts and washers zinc plated
- d. 40NB dual pipe MS. 'B' class, powder coated 60 microns black mat
- e. MS Strip for jointing powder coated 60 microns black mat with proper chemical treatment.
- f. MS clamps (pair of press parts) per set
- g. M10 x 40mm MS zinc plated hardware (bolts, nuts, washers)
- h. PVC moulded end caps for 40 NB pipe per set

Refer supporting leaflet or image bellow and technical specifications No-29. * Items are covered in BOQ. Mode of measurement and payment- Measurement and payment will be for complete one set comprising of all components as stated in above and BOQ

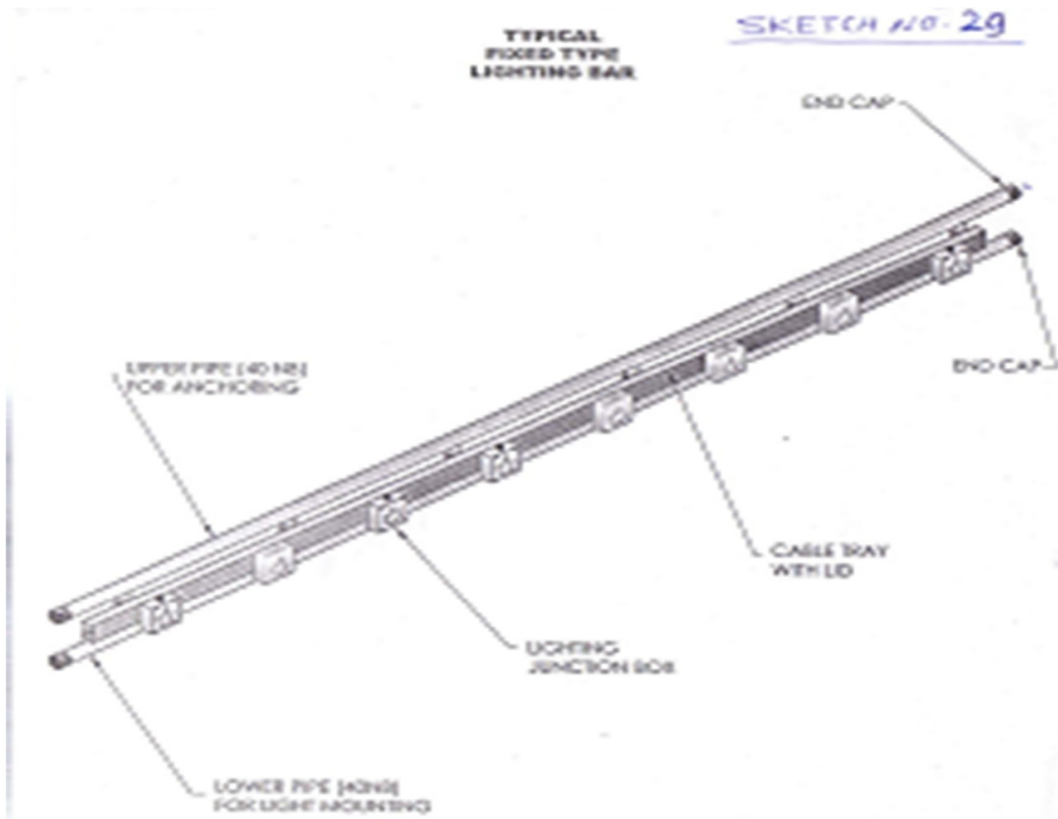

Fixed wing lighting ladder

Well engineered, designed and manufactured of Fixed wing lighting ladders (SFOH-LB) using MS 40NB class B dual barrel pipe, powder coated 60 microns black matt finish with proper chemical treatment and methodology. Having 1 metre x 1.2 metres 6 nos 16 A CEE sockets for hot lights, 4 Nos. 10 A IEC sockets for cool lights and 1 No. DMX box.

Refer supporting leaflet or image and technical specifications

Mode of measurement and payment- Measurement and payment will be for complete one set comprising of all components as stated in above and BOQ

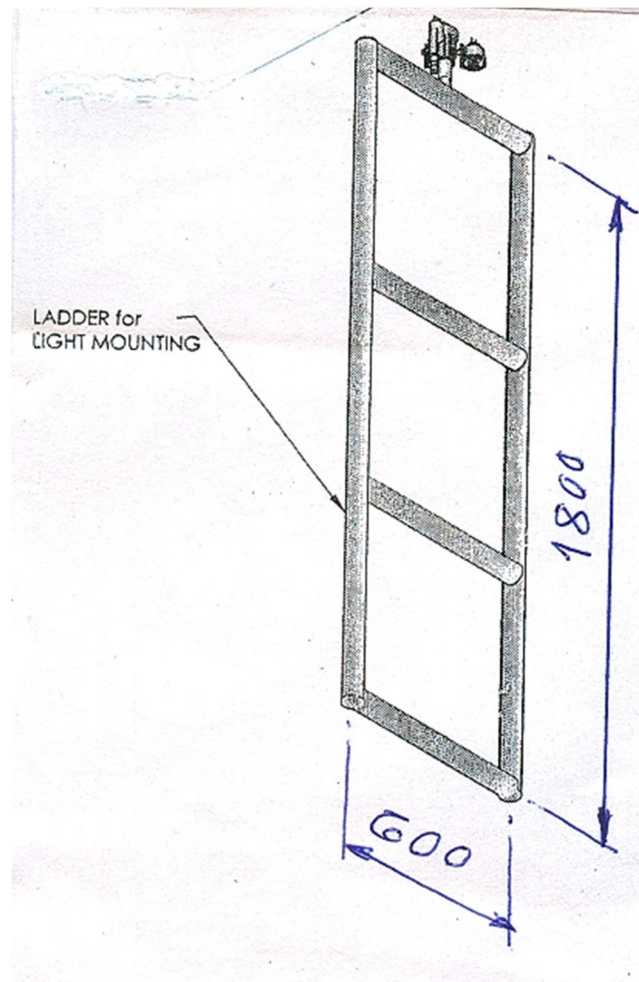

DMX male/female termination connectors.

DMX termination plugs.

Internal earthing network related to this scope of work shall be with copper 4mm dia wire duly laid on the cable trays along all the power cables. The earth wires shall be connected with all the motors, power distribution panels, motor control centre and junction boxes with the help of suitable tinned copper lugs, stainless steel fasteners as applicable.

Motorized main scallop bar

Technical Specification for Stage Drapery System

Well engineered, designed and manufactured of Motorized main scallop bar of length 24 mtrs dual barrel construction, (MS) Comprising followings with proper surface finish

- a. Necessary pulley, guide pulleys Dia 100mm x 13mm thick with bearing and mounting brackets.
- b. Ø5mm GI wire ropes with winding drum for 9 falls to suit 16 metres travel.
- c. Specially designed compact gear box Al gear box ratio 80:1 with winding drum with hardware
- d. 1.5HP, 1000 RPM, 440 V, 3PH ISI marked AC motor with DC Brake
- e. Up and down limit controller PVC moulded box, lead screw, limit switches
- f. * Motor power and control cable termination box MS box with terminals, glands and gasket (PCJB).
- g. Foundation frame ISA 50mm x 50mm x 5thk for drive unit as per site condition
- h. 40NB dual pipe MS. 'B' class, powder coated 60 microns black mat
- i. MS Strip for jointing powder coated 60 microns black mat with proper chemical treatment.
- j. MS clamps (pair of press parts) per set
- k. M10 x 40mm MS zinc plzted hardware (bolts, nuts, washers)
- l. PVC moulded end caps for 40 NB pipe per set

Refer supporting leaflet or image bellow and technical specifications No-34. * Items are covered in BOQ.

Mode of measurement and payment- Measurement and payment will be for complete one set comprising of all components as stated in above and BOQ

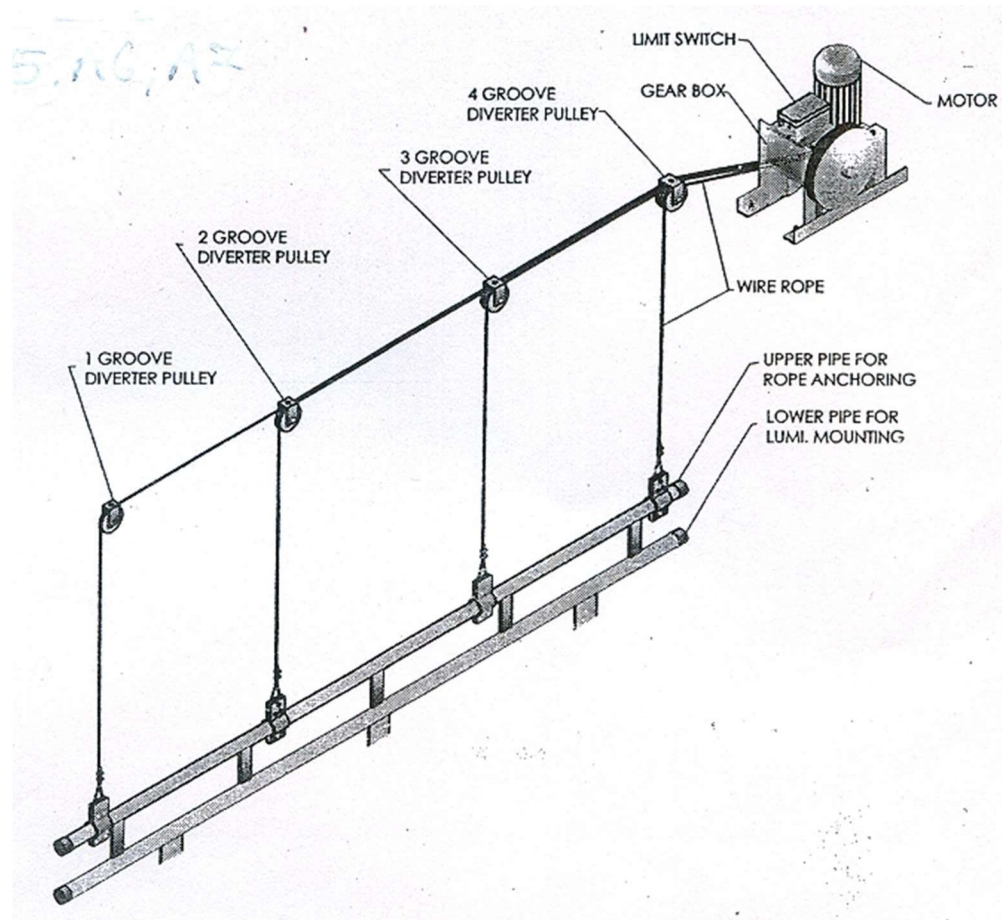

House curtain track system

Well engineered, designed and manufactured of Motorized of House curtain track system (HC) fixing arrangement 24M x 5.7M, straight shape centre parting powder coated (60 microns) with mounting arrangement at +8 m level , provided with the following.

Heavy duty aluminium track, powder coated Track mounting brackets

Electromechanical drive unit 0.75HP, 24V, DC moter specially designed compact gear box

Ø5mm GI wire ropes suitable length having 6x19 strands one fibre core construction aluminium end crimped at both end confirming to IS-3459 with winding drum.

Curtain holding trollies (110 nos. approx.) Diverter and routing pulleys (75 Dia.Approx.) Open and close limit controller

Motor cable termination box

Refer supporting leaflet and technical specifications No-35.

Mode of measurement and payment- Measurement and payment will be for complete one set comprising of all components as stated in above and BOQ

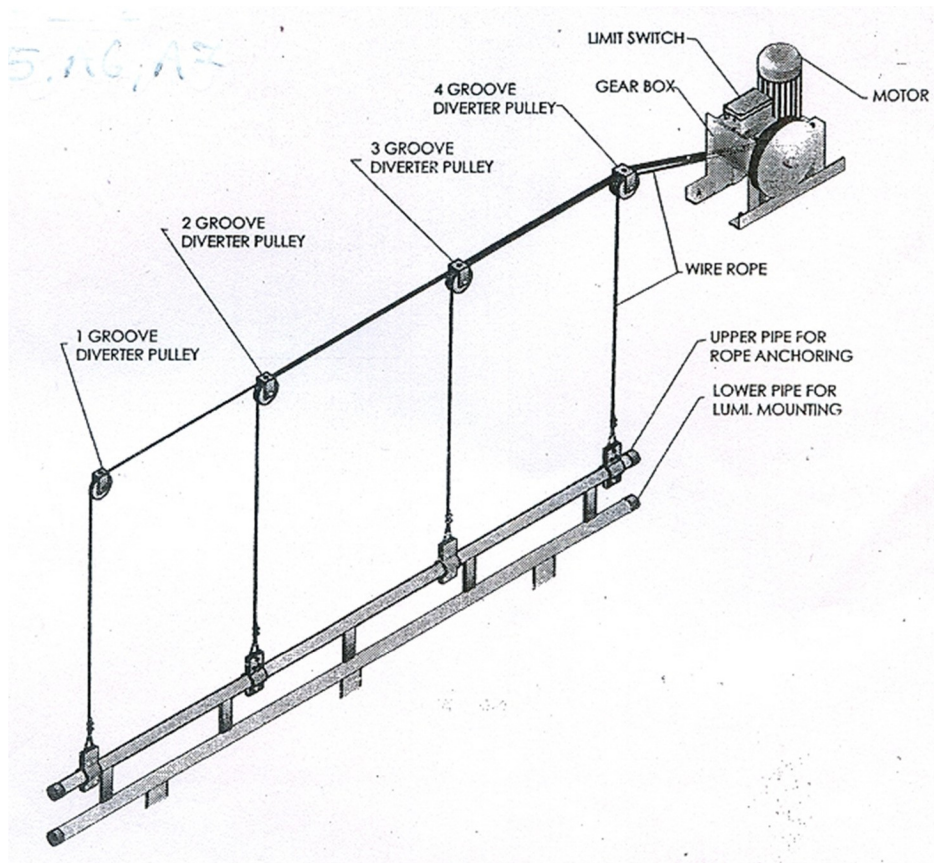

Curtain track systems

Well engineered, designed and manufactured of Motorized of Mid curtain and Rear curtain track systems (MC & RC) fixing arrangement 20M x 5M, straight shape centre parting powder coated (60 microns) with mounting arrangement at +8 m level , provided with the following. Heavy duty aluminium track, powder coated

Track mounting brackets

Electromechanical drive unit 0.75HP, 24V, DC moter specially designed compact gear box

Ø5mm GI wire ropes suitable length having 6x19 strands one fibre core construction aluminium end crimped at both end confirming to IS-3459 with winding drum.

Curtain holding trollies (110 nos. approx.) Diverter and routing pulleys (75 Dia.Approx.) Open and close limit controller

Motor cable termination box

Refer supporting leaflet and technical specifications No-36.

Mode of measurement and payment- Measurement and payment will be for complete one set comprising of all components as stated in above and BOQ

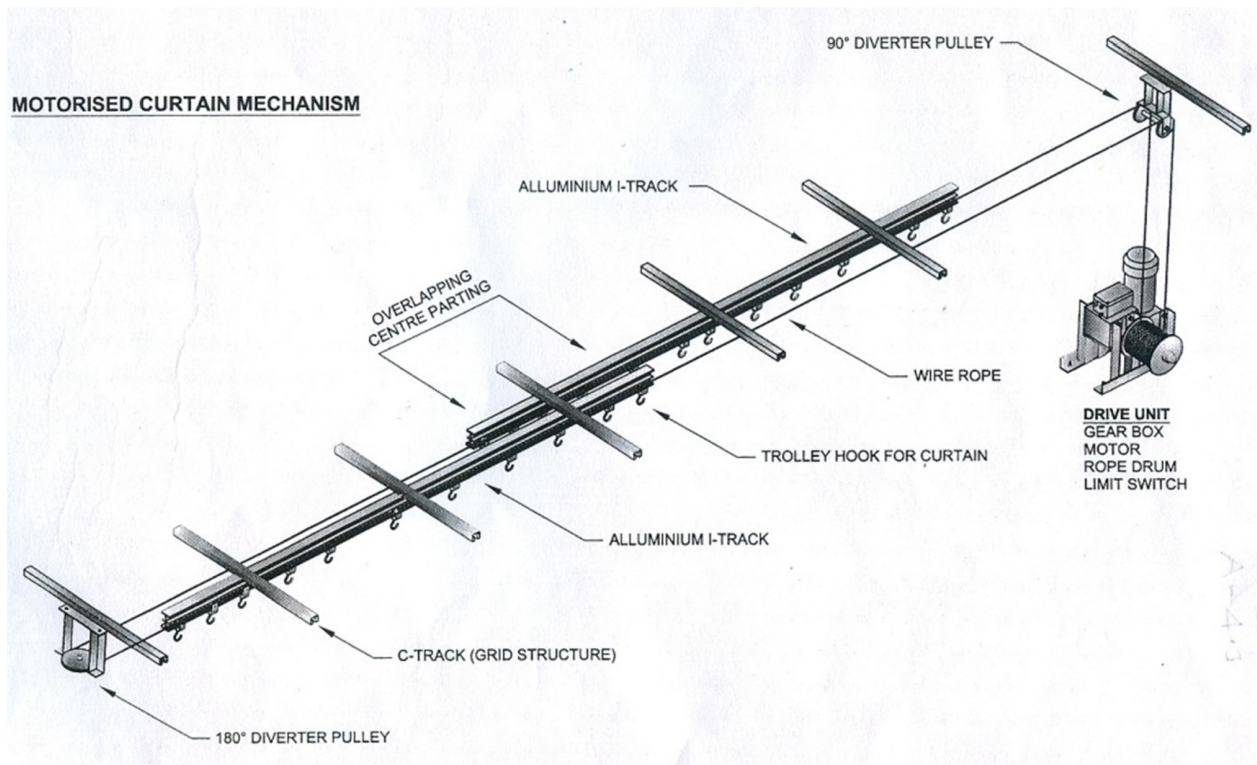

Motorized frill and utility bars

Well engineered, designed and manufactured of Motorized frill and utility bars of length 14 mtrs dual barrel construction, (FB1,FB2,FB3,FB4,FB5,FB6,FB7,UB1,UB2,UB3 & UB4) Comprising followings with proper surface finish

- a. Necessary pulley, guide pulleys Dia 100mm x 13mm thick with bearing and mounting brackets.
- b. Ø5mm GI wire ropes with winding drum for 7 falls to suit 16 metres travel.
- c. Specially designed compact gear box Al gear box ratio 80:1 with winding drum with hardware
- d. 1.5HP, 1000 RPM, 440 V, 3PH ISI marked AC motor with DC Brake
- e. Up and down limit controller PVC moulded box, lead screw, limit switches
- f. * Motor power and control cable termination box MS box with terminals, glands and gasket (PCJB).
- g. Foundation frame ISA 50mm x 50mm x 5thk for drive unit as per site condition
- h. 40NB duel pipe MS. 'B' class, powder coated 60 microns black mat
- i. MS Strip for jointing powder coated 60 microns black mat with proper chemical treatment.
- j. MS clamps (pair of press parts) per set
- k. M10 x 40mm MS zinc plzted hardware (bolts, nuts, washers)
- l. PVC moulded end caps for 40 NB pipe per set

Refer supporting leaflet or image bellow and technical specifications * Items are covered in BOQ.

Mode of measurement and payment- Measurement and payment will be for complete one set comprising of all components as stated in above and BOQ

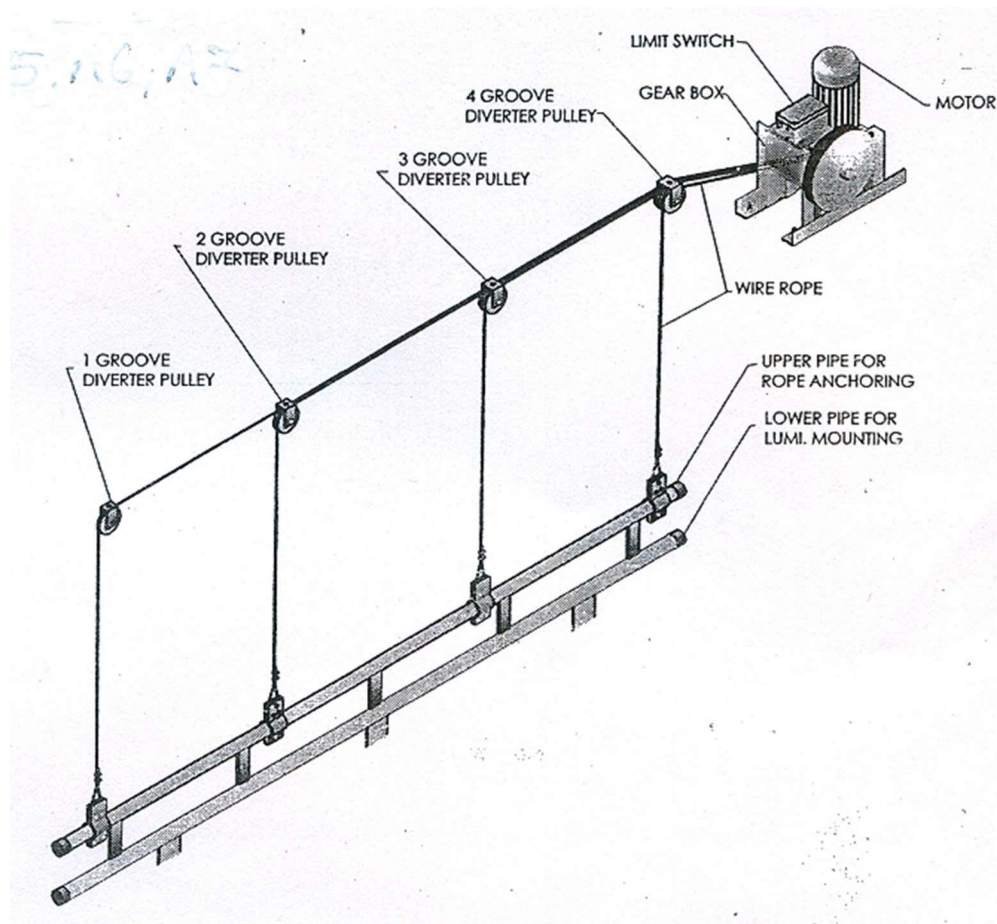

SLIDING /REVOLVING WINGS :-

Before manufacturing contractor shall approval drawing and TDS for same from Engineer & consultant MS, Wing Frame of size 1.0 & 1.5mtr x8 7mtr made from MS 25mm x 25mm x 2mm thk square pipe, powder coated 60 microns, provided with mounting arrangement - The system shall generally be comprised of the followings..

- a. 2meter wing aluminium extruded 'I' (80 x 40) track mechanism with mount brackets on MS 'C' tracks made using 3 mm thick HR strips formed track size 50 mm x 40 mm with extra inward 'U' bend for additional strenght and sliding rhombique nuts, provided with 40 mm x 13 mm oval slots at 200mm intervals duly powder coated 60 microns black matt finish.
- b. Pivot able 4wheeled suspension trolleys.
- c. Floor locking jacks.
- d. 25SQ.MS pipe.
- e. ISA 50 x 50 x 5thk for mounting.
- f. M12 hardware for mounting on floor and rear wall required

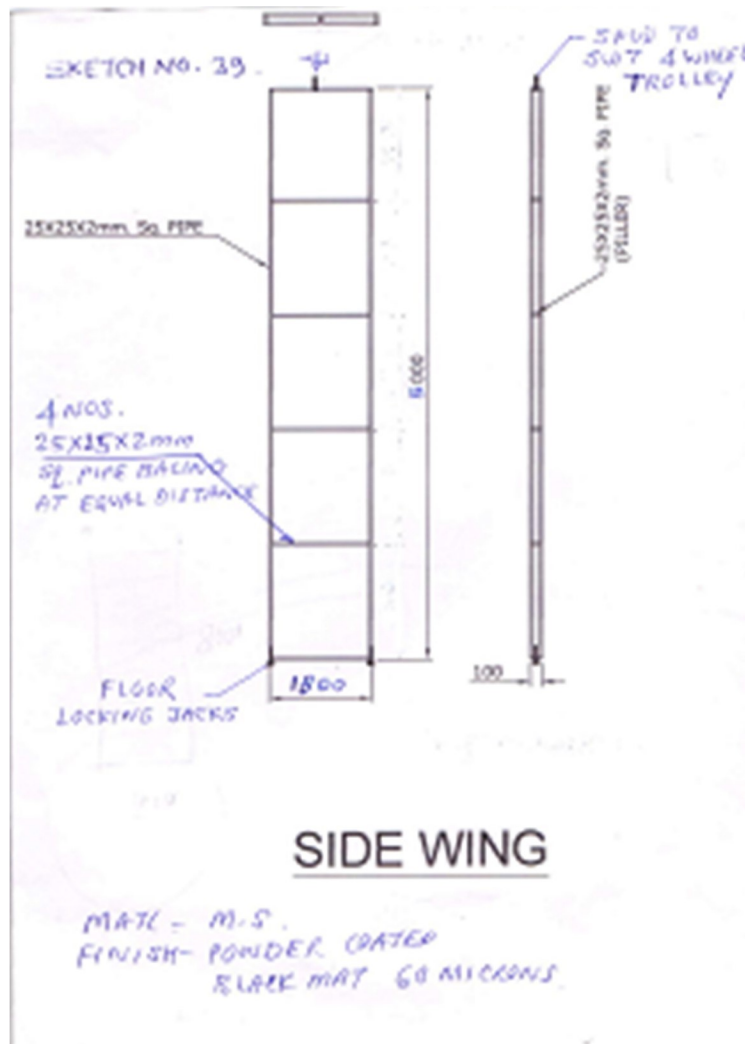

Mode of measurement and payment- Measurement and payment will be for complete one set comprising of all components as stated in above and BOQ.

Well engineered, designed and manufactured of Compact wall mount 12 feeder (MCCP-2) motor control Centre panel arrangement made out of 2 mm thick CRCA sheet with necessary mounting frame to control the motorized lighting bars, powder coated 60 microns black matt finish with proper chemical treatment and methodology. Including 1 No. 16A TPN MCB, 14 Nos. feeders consisting fuses, contactors, overload relays, emergency tripping system, step down transformer, cu. bus bars, indicating lamps, completely wired, clip on type terminals with mounting accessories, terminal marking lables, required brass cable glands, neoprene dust and vermin proof rubber gaskets, bolted inspection cover, name plates, MS hardware duly zinc plated etc.

Refer supporting leaflet and technical specifications

Mode of measurement and payment- Measurement and payment will be for complete one set comprising of all components as stated in above and BOQ

Well engineered, designed and manufactured Compact floor mount 12 feeder (RCP-2) remote control panel arrangement made out of 2 mm thick CRCA sheet with necessary mounting frame to control the motorized lighting bars, powder coated 60 microns black matt finish with proper chemical treatment and methodology. Including 14 Nos. selector switches, 1 No. up/down mode selector switch, 3 Nos. indicating lamps, completely wired, clip on type terminals with mounting accessories, terminal marking labels, required brass cable glands, neoprene dust and vermin proof rubber gaskets, bolted inspection cover, name plates, MS hardware duly zinc plated etc.

Refer supporting leaflet and technical specifications No-40.

Mode of measurement and payment- Measurement and payment will be for complete one set comprising of all components as stated in above and BOQ

Well engineered, designed and manufactured of Compact wall mount 3 feeder (MCCP-3) motor control centre panel arrangement made out of 2 mm thick CRCA sheet with necessary mounting frame to control the motorized lighting bars, powder coated 60 microns black matt finish with proper chemical treatment and methodology. Including 1 No. 16A TPN MCB, 5 Nos. feeders consisting fuses, contactors, overload relays, emergency tripping system, step down transformer, cu. bus bars, indicating lamps, completely wired, clip on type terminals with mounting accessories, terminal marking labels, required brass cable glands, neoprene dust and vermin proof rubber gaskets, bolted inspection cover, name plates, MS hardware duly zinc plated etc.

Refer supporting leaflet and technical specifications No-41.

Mode of measurement and payment- Measurement and payment will be for complete one set comprising of all components as stated in above and BOQ

Well engineered, designed and manufactured of Compact wall mount 3 feeder (RCP-3) remote control panel arrangement made out of 2 mm thick CRCA sheet with necessary

mounting frame to control the motorized lighting bars, powder coated 60 microns black matt finish with proper chemical treatment and methodology. Including 5 Nos. selector switches, 1 No. up/down mode selector switch, 3 Nos. indicating lamps, completely wired, clip on type terminals with mounting accessories, terminal marking lables, required brass cable glands, neoprene dust and vermin proof rubber gaskets, bolted inspection cover, name plates, MS hardware duly zinc plated etc.

Refer supporting leaflet and technical specifications No-41.

Mode of measurement and payment- Measurement and payment will be for complete one set comprising of all components as stated in above and BOQ

Fire retardant velvette2 fabric

Fire retardant velvette2 fabric with lining, 200% gathering for main scallop, 450 GSM, duly stitched with eyelets and approved pattern and colour fastness 4-6 shall be as decided by Engineer In-charge and the same shall generally comprising of the following:

- a. Velvette2.
- b. satin cloth.
- c. Lace.
- d. Decorative letters
- e. Decorative strip.
- f. Navar strip.
- g. Eye lets.

Mode of measurement and payment- Measurement and payment will be as per finished size of fabric.

Fire retardant velvette2 fabric with lining, 100% gathering for main house curtain, mid curtain & rear curtain centre parting, 450 GSM, duly stitched with eyelet and approved pattern and colour fastness 4-6 shall be as decided by Engineer In-charge.

- a. Velvette2.
- b. satin cloth.
- c. Lace.
- d. Decorative letters
- e. Decorative strip.
- f. Navar strip.
- g. Eye lets.

Mode of measurement and payment- Measurement and payment will be as per finished size of fabric.

Fire retardant cotton2 fabric blue for frill (FB1,FB2,FB3,FB4,FB5) 50% gathering, 450 GSM, duly stitched with eyelets and approved pattern and colour fastness 4-6 shall be as decided by Engineer In-charge.

- a. Cotton 2.
- b. Eye lets.
- c. Lace for tie 3mm dia.

- d. Mode of measurement and payment- Measurement and payment will be as per finished size of fabric.

Fire retardant cotton2 fabric blue for side wings 0% gathering, 450 GSM, duly stitched covering all sides of the frame and approved pattern and colour shall be decided by Engineer In-charge.

- a. Cotton 2.
b. Velcro tape 25mm wide.

Mode of measurement and payment- Measurement and payment will be as per finished size of fabric.

Cool Light

Installation, Testing and Commissioning of 220W (4X55W) Cool light high intensity dimmable cool light complete with colour 830 lamps,ballast,min. 3mtr IEC power and signal cables, normal yoke but without any accessories.

PAR LIGHT

Installation, Testing and Commissioning of 1000W spun aluminium PAR with floating G16d base lamp socket, min. 3mtrs power 16A CEE cord and filter frame but without lamp.

1000W spun aluminium PARCAN made out of spun aluminium 16 SWG in 2 piece cylindrical construction with punched slot on Parcan housing for natural ventilation and floating ceramic GX16d base lamp socket, 3mtr copper flexible PVC insulated power cable with 3 pin CE insulated plug, Yoke made of MS flat 25 X 3mm with 13mm free mounting hole to fit the adaptor, spigot with 28mm and filter frame and with all necessary accessories but without lamp.