



E-TENDER

FOR

Name of Work: Major Structural Repairs to Municipal Buildings Nos 50
Tenements & 72 Tenements at Peru Chawl, Gas Company lane,
Lalbaug in F/South ward.

Sd-
S.E (B.M.) F/S

Sd-
A.E.(B.M.)City

Sd-
E.E.(B.M.)City-II

-Sd-
Dy. Ch. E. (B. M.) City

Ch.E. (B.M.)'s office,
3 rd floor, Engineering Hub Building,
Dr.E.Moses Road, Worli Naka, Worli,
Mumbai 400 018.

This page is intentionally left blank.

INDEX

SECTION	DESCRIPTION	PG-NO
1	E-TENDER NOTICE	04
2	ELIGIBILITY CRITERIA	10
3	DISCLAIMER	14
4	INTRODUCTION	17
5	E-TENDERING ONLINE SUBMISSION PROCESS	20
6	INSTRUCTIONS TO APPLICANTS	24
7	SCOPE OF WORK	50
8	BILL OF QUANTITIES	52
9	GENERAL CONDITIONS OF CONTRACT	123
10	SPECIFICATIONS& SELECTION OF MATERIAL	200
11	FRAUD AND CORRUPT PRACTICES	213
12	PRE-BID MEETING	218
13	LIST OF APPROVED BANKS	220
14	SPECIAL DIRECTIONS TO TENDERER	224
15	APPENDIX	229
16	AGREEMENT FORM	234
17	ANNEXURE A, ANNEXURE B,ANNEXURE C, ANNEXURE D&ANNEXURE E	238
18	BANKERS GUARANTEE	247
19	PROFORMAS & SPECIAL ANNEXURE I	249
20	IRREVOCABLE UNDERTAKING	252

This page is intentionally left blank.

SECTION 1

E-TENDER NOTICE

BRIHANMUMBAI MUNICIPAL CORPORATION

Chief Engineer (Building Maintenance)

Ch. E./B.M./13450/II dtd. 13.10.2022

E-TENDER NOTICE

The Municipal Corporation of Greater Mumbai (MCGM) invites e-tender to appoint Contractor for the aforementioned work from contractors of repute, multidisciplinary engineering organizations i.e. eminent firm, Proprietary/Partnership Firms/ Private Limited Companies/ Public Limited Companies/Companies registered under the Indian companies' act 2013, the contractors registered with the Municipal Corporation of Greater Mumbai, (MCGM) in **Class 'II' & above as per new registration** and from the contractors/firms equivalent and superior classes registered in Central or State Government/Semi Govt. Organization/Central or State Public Sector Undertakings, will be allowed subject to condition that, the contractors who are not registered with MCGM will have to apply for registering their firm within three months time period from the award of contract, otherwise their Bid Security i.e. E.M.D (Earnest Money Deposit) will be forfeited/recovered and an amount equal to Registration Fee of respective class will be recovered as penalty.

Bidding Process will comprise of THREE stages.

The application form can be downloaded from MCGM's portal (<http://portal.mcgm.gov.in>) on payment of Rs.10,400+ 18% GST (9% CGST+9% SGST). The applicants not registered with MCGM are mandated to get registered (Vendor Registration) with MCGM for e-tendering process & obtain login credentials to participate in the online bidding process

- i) To download the application form, for those applicants not having vendor registration, need to apply first for vendor registration at the office of Account Officer (FAR), 4th floor, Municipal Headquarter.
- ii) Followed by SRM login ID and password to be obtained from Central Purchase Department (CPD), Office at Byculla, Bakariadda, Mumbai
- iii) For e-Tendering registration, enrolment for digital signature certificates and user manual, please refer to respective links provided in 'Tenders' tab. Vendors

can get digital signature from any one of the Certifying Authorities (CA's) licensed by controller of certifying authorities namely, Safes crypt, IDRBT, National informatics Center, TCS, CUSTOMS, MTNL, GNFC and e- Mudhra.

Name and location of work	Contract period	Estimated Cost of Project
Major Repairs to Municipal Buildings Nos 50 Tenements & 72 Tenements at Peru Chawl, Gas Company Lane, Lalbaug in F/South ward.	12 Months (Inclusive of monsoon period)	3,32,86,609.00/-

In terms of the 3 stage system of e-tendering, a Bidder will be required to deposit, along with its Bid, an **Earnest Money Deposit of Rs. 3,32,900/- (Rupees Three Lakh thirty two Thousand nine hundred only)** (the "EMD"), refundable in accordance to the relevant clause of bid document, from the Bid Due Date, except in the case of the selected Bidder whose Bid Security/EMD shall be retained. The Bidders will have to provide Earnest Money Deposit through the payment gateways while submitting the bids. The Bid shall be summarily rejected if it is not accompanied by the Earnest Money Deposit. The e-tender is available on MCGM portal (<http://portal.mcg.gov.in>) as mentioned in the Header Data of the tender.

As per THREE Packet systems, the document for Packet A & B is to be uploaded by the bidder in vendors' document online in Packet A, B. Packet A, B & C shall be opened on dates as mentioned in header data. All the responsive and eligible bidders if they so wish can be present at the time of opening of bids, in the office of Chief Engineer (Building Maintenance). The Packet C shall be opened if bids submission in Packet A & B satisfies/includes all the requirements and same are found acceptable to the Authority.

The Municipal Commissioner reserves the right to reject all or any of the e-tender(s) without assigning any reasons at any stage.

The dates and time for submission and opening the bids are as shown in the Header Data. If there are any changes in the dates the same will be displayed on the MCGM Portal. (<http://portal.mcgm.gov.in>).

The Applicants interested for the above referred works may contact the Chief Engineer (Building Maintenance) at the following address on any working day during office hours.

Chief Engineer (Building Maintenance)'s office,

3 rd floor, Engineering Hub Building,
Dr.E.Moses Road, Worli Naka, Worli,
Mumbai 400 018.

The applicants may wish to visit the site under reference located at Municipal Buildings known as 50 Tenements & 72 Tenements at Peru Chawl, Gas Company Lane, Lalbaug in F/South ward Mumbai, Maharashtra, India and can collect the information of the present status from the department who have invited the bids.

The MCGM reserves the rights to accept any of the application or reject any or all the application received for above works, without assigning any reasons thereof. The information regarding above subject matter is available on Website of MCGM. (<http://portal.mcgm.gov.in/tenders>).

-Sd-

Dy. Ch. E. (B. M.) City

HEADER DATA

Tender Document Number	7200037584
Name of Organization	Municipal Corporation of Greater Mumbai
Subject	Major Structural Repairs to Municipal Buildings known as 50 Tenements & 72 Tenements at Peru Chawl, Gas Company lane, Lalbaug in F/South ward.
Cost of Tender	Rs.10,400 + 18% GST (9% CGST+9% SGST).
Cost of E-Tender (Estimated Cost)	Rs.3,32,86,609/-
Bid Security Deposit/Earnest Money Deposit	Rs. 3,32,900/-
Date of issue and sale of tender	18/10/2022 from 11:00 AM
Date of Pre-bid Meeting	Nil
Pre-bid Meeting Venue	Nil
Last date & time for sale of tender	31/10/2022 up to 12:00 Hours
Submission of Packet A,B & C (Online)&Receipt of Bid Security Deposit	31/10/2022 up to 16:00 Hours
Opening of Packet – A	31/10/2022 after 16:01 Hours
Opening of Packet – B	31/10/2022 after 16:02 Hours
Opening of Packet – C	11/11/2022 after 15:00 Hours
Address for communication	Office of the:- Chief Engineer (BM), 3 rd floor, Engineering Hub Building, Dr.E.Moses Road, Worli Naka, Worli, Mumbai-018
Venue for opening of bid	Online in Ch. Engg. (BM)'s office.

This tender document is not transferable.

The MCGM reserves the rights to accept any of the application or reject any or all the application received for above subject without assigning any reason thereof.

**-Sd-
Dy. Ch. E. (B. M.) City**

SECTION 2
ELIGIBILITY CRITERIA

A. Technical Capacity

- (1) The tenderer(s) in their own name should have satisfactorily executed the work of similar nature in MCGM /Semi Govt. /Govt. & Public Sector Organizations in during last seven (7) years ending last day of month previous to the one in which bids are invited as a prime Contractor (or as a nominated sub-Contractor, where the subcontract had involved similar nature of work as described in the scope of works in this bid document, provided further that all other qualification criteria are satisfied)
- a) Three similar completed works each of value not less than the value equal to **20%** of estimated cost put to tender

Or

 - b) Two similar completed works each of value not less than the value equal to **25%** of estimated cost put to tender.

Or

 - c) One similar completed work of value equal and or not less than the **40%**of estimated cost put to tender

The value of executed works shall be brought to current costing level by enhancing the actual value of work at compound rate of 10 % per annum; calculated from the date of completion to last date of receipt of applications for tenders.

- (2) **Similar Experience:** For assessing the technical capacity of Major structural repairs and Maintenance works; Similar work shall mean, the completed or ongoing works in Building Construction OR Building Maintenance such as repairs/retrofitting /structural repairs .

“In case of ongoing works to be considered, the bidder must have received payment bills of 80% of the contract sum for the work/works executed last day of month previous to the one in which bids are invited”.

Financial Capacity

Achieved an average annual financial turnover as certified by 'Chartered Accountant' (in all classes of civil engineering construction works only) equal to 30% of the estimated cost of work in last three (3) financial years immediately preceding the Financial Year in which bids are invited.

The value of executed works shall be brought to current costing level by enhancing the actual value of work at compound rate of 10 % per annum; calculated from the date of completion to last date of receipt of applications for tenders.

B. Bid Capacity:

The bid capacity of the prospective bidders will be calculated as under

$$\text{Assessed Available Bid Capacity} = (A * N * 2 - B)$$

Where,

A = Maximum value of Civil Engineering works executed in any one year (year means Financial year) during the last five years (updated to the price level of the Financial year in which bids are received at a rate of 10% per year) taking into account the completed as well as works in progress.

N = Number of years prescribed for completion of the Project/Works, excluding monsoon period, for which these bids are being invited. (E.g. 7 months = 7/12 year) For every intervening monsoon 0.33 shall be added to N.

B = Value of existing commitments (only allotted works) on the last date of submission of bids as per bidding document and on-going works to be completed during the period of completion of the Project/Works for which these bids are being invited.

Note: The statement showing the value of existing commitments and on-going works as well as the stipulated period of completion remaining for each of the works listed should be attached along with certificates duly signed by the Engineer-in Charge, not below the rank of an Executive Engineer or equivalent.

Even though the bidders meet the above qualifying criteria, they are subject to be disqualified if they have:

- made misleading or false representation in the forms, statements and attachments submitted in proof of the qualification requirements; and/or
- Record for poor performance such as abandoning the works, not properly completing the contract, inordinate delays in completion, or financial failures etc

SECTION 3

DISCLAIMER

DISCLAIMER

The information contained in this e-tender document or provided to Applicant(s), whether verbally or in documentary or any other form, by or on behalf of the Municipal Corporation of Greater Mumbai (MCGM), hereafter also referred as “The Authority “, or any of its employees or advisors, is provided to Applicant(s) on the terms and conditions set out in this e-tender and such other terms and conditions subject to which such information is provided.

This e-tender includes statements, which reflect various assumptions and assessments arrived at by the Municipal Corporation of Greater Mumbai (MCGM) in relation to the Project. Such assumptions, assessments and statements do not purport to contain all the information that each Applicant may require. This e-tender may not be appropriate for all persons, and it is not possible for the Municipal Corporation of Greater Mumbai (MCGM), its employees or advisors to consider the investment objectives, financial situation and particular needs of each party who reads or uses this e-tender. The assumptions, assessments, statements and information contained in this e-tender may not be complete, accurate, adequate or correct. Each Applicant should therefore, conduct its own investigations and analysis and should check the accuracy, adequacy, correctness, reliability and completeness of the assumptions, assessments, statements and information contained in this e-tender and obtain independent advice from appropriate sources.

Information provided in this e-tender to the Applicant(s) is on a wide range of matters, some of which may depend upon interpretation of law. The information given is not intended to be an exhaustive account of statutory requirements and should not be regarded as a complete or authoritative statement of law. The Municipal Corporation of Greater Mumbai (MCGM) accepts no responsibility for the accuracy or otherwise for any interpretation or opinion on law expressed here.

The Municipal Corporation of Greater Mumbai(MCGM), its employees and advisors make no representation or warranty and shall have no liability to any person, including any Applicant or Bidder, under any law, statute, rules or regulations or tort, principles of restitution or unjust enrichment or otherwise for any loss, damages, cost or expense which may arise from or be incurred or suffered on account of anything contained in this e-tender or otherwise, including the accuracy, adequacy, correctness, completeness or reliability of the e-tender and any assessment, assumption, statement or information contained therein or

deemed to form part of this e-tender or arising in any way with pre-qualification of Applicants for participation in the Bidding Process. The Municipal Corporation of Greater Mumbai (MCGM) also accepts no liability of any nature whether resulting from negligence or otherwise howsoever caused arising from reliance of any Applicant upon the statements contained in this e-tender.

The Municipal Corporation of Greater Mumbai (MCGM) may, in its absolute discretion but without being under any obligation to do so, update, amend or supplement the information, assessment or assumptions contained in this e-tender.

The issue of this e-tender does not imply that the Municipal Corporation of Greater Mumbai (MCGM) is bound to select and short-list pre-qualified Applications for Bid Stage or to appoint the selected Bidder or Concessionaire, as the case may be, for the Project and the Municipal Corporation of Greater Mumbai (MCGM) reserves the right to reject all or any of the Applications or Bids without assigning any reasons whatsoever.

The Applicant shall bear all its costs associated with or relating to the preparation and submission of its Application including but not limited to preparation, copying, postage, delivery fees, expenses associated with any demonstrations or presentations which may be required by The Municipal Corporation of Greater Mumbai (MCGM) or any other costs incurred in connection with or relating to its Application. All such costs and expenses will remain with the Applicant and the Municipal Corporation of Greater Mumbai (MCGM) shall not be liable in any manner whatsoever for the same or for any other costs or other expenses incurred by an Applicant in preparation or submission of the Application, regardless of the conduct or outcome of the Bidding Process.

SECTION 4

INTRODUCTION

INTRODUCTION

1. Background:

The Municipal Corporation of Greater Mumbai covers an area of 437.71sq.kms.with a population of 1.24 Crores as per census of 2011. The metropolis accounts major portion of India's international trade and government's revenue, from being one of the foremost centers of education, science and technological research and advancement.

The Mumbai Metropolis has historic tradition of strong civic activism dedicated to the cause of a better life for all its citizens. And it's the Municipal Corporation of Greater Mumbai (MCGM), hereafter called the "corporation", the primary agency responsible for urban governance in Greater Mumbai.

MCGM (The Authority) is one of the largest local self-governments in the Asian Continent. In observance of historic traditions of strong civic activism, with the change in time and living conditions to match with the urbanization, MCGM has mainly focused in providing almost all kinds of engineering services viz, Hydraulics, storm water drain, sewerage, water supply projects, roads, bridges, solid waste management, and environmental services. Beside this, the MCGM is also providing dedicated services in various segments such as Health, Primary Education as well as the construction and maintenance of Public Markets and Slaughter Houses.

MCGM is an organization having different departments, right from engineering depts. to health depts. Moreover we have other dept. like education, market, fire brigade dept., Octroi and other such departments where quite a good number of staff members are working.

Scope of Work:

MCGM is primarily an organization, which in the interest of citizens and with the speed of urbanization deals with the variety of the infrastructure services and delivered to the public by different departments like Water Supply Projects, Sewerage Projects, Hydraulics, Storm Water Drain/Roads and bridges and Building Construction etc.

Scope of work:

Proposed work comprises of,

1. Structural Repairs by using P. M. M., Micro-concrete, and RCC work wherever required.
2. WPT works to terrace, WC, Bath, OHWT and chajja.
3. Internal plaster for common area & for the rooms wherever required.
4. External plaster.
5. Internal & external painting.
6. Kota flooring for common area, Kota Riser & tread, Ceramic flooring & Dado work wherever required.
7. Provisional Qty. of Structural steel and providing SS railing.
8. Masonry works
9. Other ancillary work such as Anti- termite treatment, & FRP doors, plumbing & sanitation work, dismantling & demolition work etc. and necessary electrification work.

SECTION 5

E-TENDERING ONLINE SUBMISSION PROCESS

E-TENDERING ONLINE SUBMISSION PROCESS

The terminology of e-Tendering is solely depending upon policies in existence, guidelines and methodology adopted since decades. The SRM is only change in process of accepting and evaluation of tenders in addition to manual. The SAP module to be used in this E-tendering is known as Supplier Relationship Module (SRM).SRM is designed and introduced by ABM Knowledge ware Ltd. who will assist MCGM in throughout the tendering process for successful implementation.

NOTE: This tendering process is covered under Information Technology ACT & Cyber Laws as applicable

(1) In e-tendering process some of the terms and its definitions are to be read as under wherever it reflects in online tendering process.

Start Date read as “Sale Date”

End Date read as “Submission Date”

Supplier read as “Contractor/bidder”

Vendor read as “Contractor/bidder”

Vendor Quotation read as “Contractors Bid/Offer”

Purchaser read as “Department/MCGM”

I. Before entering in to online tendering process, the contractors should complete the registration process so as to get User ID for E-tendering links. For this, the contractors can access through Supplier registration via MCGM Portal.

There are two methods for this registration :(II and III)

II. Transfer from R3 (registered contractors with MCGM) to SRM

- a. Contractors already registered with MCGM will approach to Vendor Transfer cell.
- b. Submit his details such as (name, vendor code, address, registered Email ID, pan card etc.) to Vendor transfer cell.
- c. MCGM authority for Vendor Transfer, transfers the Vendor to SRM application from R3 system to SRM system.
- d. Transferred Vendor receives User ID creation link on his supplied mail Id.
- e. Vendor creates his User ID and Password for e-tendering applications by accessing link sent to his mail ID.

III. Online Self Registration (Temporary registration for applicant not registered with MCGM)

- a. Vendor fills up Self Registration form via accessing MCGM portal.
- b. Vendor Transfer cell (same as mentioned above) accesses Supplier Registration system and accepts the Vendor request.
- c. Accepted Vendor receives User ID creation email with Link on his supplied mail Id.
- d. Vendor creates his User ID and Password for e-tendering application.

IV. CONTRACTORS BIDDING: Applicant will Quote and Upload Tender Documents

1. Access e-tender link of SRM Portal
2. Log in with User ID and Password
3. Selects desired Bid Invitation (he wants to bid)
4. To download tender documents contractors will have to pay online Tender fee. The same can be done by accessing Pay Tender Fees option. By this one will be able to pay Tender fee through Payment Gateway-If transaction successful, Contractors can register his interest to participate. Without Registration one cannot quote for the Bid/Tender.
5. Applicant will download Tender Documents from Information from purchaser tab by accessing Purchaser document folder through collaboration 'C' folder link.
6. Applicant will upload Packet A related and Packet B related Documents in Packet A and Packet B folder respectively by accessing these folders through "My Notes" Tab and collaboration folder link.
7. All the documents uploaded have to be digitally signed and saved. Contractors can procure there digital signature from any certified CA's in India.
8. Bid security deposit/EMD, if applicable, should be paid online as mentioned in tender.
9. For commercial details (in Packet C) contractors will fill data in Item Data tab in Service Line Item via details and quotes his "Percentage Variation" (i.e.% quoted) figure.(If entered '0' it will be treated as at par. By default the value is zero only.
10. Applicants to check the bid, digitally signs & save and submit his Bid Invitation.

11. Applicants can also save his uploaded documents/commercial information without submitting the BID for future editing through 'HOLD' option.
12. Please note that "Hold" action do not submit the Bid.
13. Applicants will receive confirmation once the Bid is submitted.
14. Bid creator (MCGM) starts Bid Opening for Packet A after reaching End Date and Time and Bid Evaluation process starts.

As per Three Packet system, the document for Packet A& B are to be uploaded by the tenderer in 'Vendor's document' online in Packet A & B. Before purchasing/downloading the tender copy, tenderer may refer to post- Qualification criteria mentioned in e-Tender Notice.

The tenderer shall pay the EMD/Bid Security through payment gateways before submission of Bid and shall upload the screenshot of receipt of payment in Packet 'A' instead of paying the EMD at any of the CFC centers in MCGM Ward Offices.

The e-tender is available on MCGM portal, <http://portal.mcg.gov.in>, as mentioned in the Header Data of the tender. The tenders duly filled in should be uploaded and submitted online on or before the end date of submission. The Packet 'A', Packet 'B' & Packet 'C' of the tenderer will be opened as per the timetable shown in the Header Data in the office of **Chief Engineer (Building Maintenance)**

The Municipal Commissioner reserves the right to reject all or any of the e-Tender(s) without assigning any reason at any stage. The dates and time for submission and opening the tenders are as shown in the Header Data. If there are any changes in the dates the same will be displayed on the MCGM Portal (<http://portal.mcg.gov.in>).

SECTION 6

INSTRUCTIONS TO APPLICANTS

INSTRUCTIONS TO APPLICANTS

Scope of Application

The Authority wishes to receive Applications for Qualification in order to SELECT experienced and capable Applicants for the Bid Stage.

Eligibility of Applicants

The Municipal Corporation of Greater Mumbai (MCGM) invites e-tender to appoint Contractor for the aforementioned work from contractors of repute, multidisciplinary engineering organizations i.e. eminent firm, Proprietary/Partnership Firms/ Private Limited Companies/ Public Limited Companies/Companies registered under the Indian companies' act 2013, the contractors registered with the Municipal Corporation of Greater Mumbai, (MCGM) in **Class 'II' & above** as per new registration and from the contractors/firms equivalent and superior classes registered in Central or State Government/Semi Govt. Organization/Central or State Public Sector Undertakings, will be allowed subject to condition that, the contractors who are not registered with MCGM will have to apply for registering their firm within three months' time period from the award of contract, otherwise their Bid Security i.e. E.M.D (Earnest Money Deposit) will be forfeited/recovered and an amount equal to Registration Fee of respective class will be recovered as penalty.

To be eligible for pre-qualification and short-listing, an Applicant shall fulfil the following conditions of eligibility:

A. Technical Capacity

- (1) The tenderer(s) in their own name should have satisfactorily executed the work of similar nature in MCGM /Semi Govt. /Govt. & Public Sector Organizations in during last seven (7) years ending last day of month previous to the one in which bids are invited as a prime Contractor (or as a nominated sub-Contractor, where the subcontract had involved similar nature of work as described in the scope of works in this bid document, provided further that all other qualification criteria are satisfied)
- a) **Three** similar completed works each of value not less than the value equal to **20%** of estimated cost put to tender

Or

- b) **Two** similar completed works each of value not less than the value equal to **25%** of estimated cost put to tender.

Or

- c) **One** similar completed work of value equal and or not less than the **40%** of estimated cost put to tender

The value of executed works shall be brought to current costing level by enhancing the actual value of work at compound rate of 10 % per annum; calculated from the date of completion to last date of receipt of applications for tenders.

(2) **Similar Experience:** For assessing the technical capacity of major structural repairs and maintenance works; Similar work shall mean, the completed or ongoing works in Building Construction OR Building Maintenance such as repairs/retrofitting /structural repairs.

“In case of ongoing works to be considered, the bidder must have received payment bills of 80% of the contract sum for the work/works executed last day of month previous to the one in which bids are invited”.

B. Financial Capacity

Achieved an average annual financial turnover as certified by ‘Chartered Accountant’ (in all classes of civil engineering construction works only) equal to **30%** of the estimated cost of work in **last three (3) financial years** immediately preceding the Financial Year in which bids are invited.

The value of executed works shall be brought to current costing level by enhancing the actual value of work at compound rate of 10 % per annum; calculated from the date of completion to last date of receipt of applications for tenders.

C. Bid Capacity:

The bid capacity of the prospective bidders will be calculated as under

Assessed Available Bid Capacity = $(A * N^2 - B)$

Where,

A = Maximum value of Civil Engineering works executed in any one year (year means Financial year) during the last five years (updated to the price level of the Financial year in which bids are received at a rate of 10% per year) taking into account the completed as well as works in progress.

N = Number of years prescribed for completion of the Project/Works, excluding monsoon period, for which these bids are being invited. (E.g. 7 months = 7/12 year) For every intervening monsoon 0.33 shall be added to N.

B = Value of existing commitments (only allotted works) on the last date of submission of bids as per bidding document and on-going works to be completed during the period of completion of the Project/Works for which these bids are being invited.

Note: The statement showing the value of existing commitments and on-going works as well as the stipulated period of completion remaining for each of the works listed should be attached along with certificates duly signed by the Engineer-in Charge, not below the rank of an Executive Engineer or equivalent.

Even though the bidders meet the above qualifying criteria, they are subject to be disqualified if they have:

- made misleading or false representation in the forms, statements and attachments submitted in proof of the qualification requirements; and/or
- Record for poor performance such as abandoning the works, not properly completing the contract, inordinate delays in completion, or financial failures etc

D. Equipment Capabilities as required for this work:

The successful bidder will make the arrangements of the required equipment on the day of commencement or with respect to the progress of the work in phases, as per the instructions of site in charge. The successful bidder will ensure commitment in this respect on an undertaking on Rs.500 stamp paper to be

submitted along with the Bid in Packet B. However, this condition in no way shall dilute the respective condition in Registration Rules of MCGM.

E. Technical Personnel

The contractor and/or its managerial staff should have qualification/experience appropriate to the function they fulfill. The minimum standard shall be increased by asking that at least one number or more of the contractor or its managerial staff have acquired qualifications or work experience to the needs of the contract. The minimum standard may also state that the person or persons responsible for managing the works must have a minimum of no's of years' experience working on similar nature of projects.

For fixing requirement of Technical Staff as required for this work.

(B) General Guidelines for Fixing Requirement of Technical Staff

(A)

Cost of work (Rs inCrore)	Requirement of Technical Staff		Minimum Experience(year)	Designation
	Qualification	Number		
10 to 20	i)Project Manager with degree in corresponding discipline of Engineering	1	10	Principal Technical Representative
	ii)Graduate Engineer	1	5	Technical Representative
	iii) Graduate Engineer or	2	2	
	Diploma Engineer	2	5	Project/Site Engineer and Project Planning/ billing Engineer

5 to10	i) Graduate Engineer	1	5	Principal Technical Representative
	ii)Graduate Engineer or Diploma Engineer	2	2	Project/Site Engineer
		2	5	Engineer
More than 1.5 to 5	i) Graduate Engineer	1	5	Principal Technical Representative
	ii)Graduate Engineer or Diploma Engineer	1	2	Project/Site Engineer
		1	5	Billing Engineer
Upto 1.5	ii)Graduate Engineer or Diploma Engineer	1	2	Principal Technical Representative
		1	5	Project/Site Engineer

Notes –

1. “Cost of work”, in table above, shall mean the agreement amount of the work.
2. Rate of recovery in case of non-compliance of the clause be stipulated at following rates:-

Sr. No.	Qualification	Experience(years)	Rate of Recovery
1	Project Manager with degree	10	Rs.30000/-p.m.
2	Graduate Engineer	5	Rs.25000/-p.m.
3	Graduate Engineer	2	Rs.15000/-p.m.
4	Diploma Engineer	5	Rs.15000/-p.m.

3. Nothing extra need to be added while preparing market rate justified amount of the work if stipulation is made as per above recommended scale of technical staff.
4. Requirement of technical staff and their experience can be varied depending upon nature of work by competent authority i.e. Chief Engineer with recorded reasons.

F. TIME PERIOD OF THE PROJECT

Entire project should be completed and delivered within **12months**(Inclusive of Monsoon) of time from the date of award of contract that includes Monsoon.

The time allowed for carrying out the work as entered in the Tender shall be strictly observed by the Contractor and shall be reckoned from the date on which the Letter of Acceptance is given to the Contractor. The work shall throughout the stipulated period of the Contract be proceeded with all due diligence as time being deemed to be the essence of the contract on the part of the Contractor. On failing to do so, the Contractor shall pay as compensation an amount which shall be governed as per Clause - 8(e) of Standard General Conditions of Contract

The Contractor should complete the work as per phase given below:

¼ of the work in	..	¼ of the time
½ of the work in	..	½ of the time
¾ of the work in	..	¾ of the time
Full of the work in	..	Full of the time

Full work will be completed in **12months** including monsoon.

The programme for completion of work shall be a part of the Contract Document in the form of Bar Chart / GANTT Chart. The Contractor is supposed to carry out the work and keep the progress as per Bar Chart/GANTT Chart. The Contractor shall complete the work as per the Schedule given in the Contract and the programme submitted by the Contractor.

G. Contract Execution

All required documents for execution of the contract shall be submitted within 30 days from the date of issue of letter of acceptance. If the documents are not submitted within the stipulated time a penalty of Rs 5000/- per day will be applicable to the contractor. All contract documents need to be duly affixed with stamp duty properly signed along with evidence/proof of payment of security/contract deposit/ within 30 days from the date of letter of acceptance received by him

- H.** If the amount of the Contract Deposit to be paid above is not paid within 30 days from the date of issue of Letter of Acceptance, the Tender / Contractor already accepted shall be considered as cancelled and legal steps be taken against the contractor for recovery of the amounts.
- I.** The amount of Security Deposit retained by the MCGM shall be released after expiry of period up to which the contractor has agreed to maintain the work in good order is over. In the event of the contractor failing or neglecting to complete the rectification work within the period up to which the contractor has agreed to maintain the work in good order, the amount of security deposit retained by MCGM shall be adjusted to-wards the excess cost incurred by the Department on rectification work.

J. Action when whole of security deposit is forfeited:

In any case in which under any Clause of this contract, the contractor shall have rendered himself liable to pay compensation amounting to the whole of this security deposit whether paid in one sum or deducted by instalments or in the case of abandonment of the work owing to serious illness or death of the contractor or any other cause, the Engineer on behalf of the Municipal Commissioner shall have power to adopt any of the following process, as he may deem best suited to the interest of MCGM -

- (a) To rescind the contract (for which recession notice in writing to the contractor under the head of Executive Engineer shall be conclusive evidence) and in that case, the security deposit of the contract shall stand forfeited and be absolutely at the disposal of MCGM.
- (b) To carry out the work or any part of the work departmentally debiting the contractor with the cost of the work, expenditure incurred on tools and plant, and charges on additional supervisory staff including the cost of work-charged establishment employed for getting the un-executed part of

the work completed and crediting him with the value of the work done departmentally in all respects in the same manner and at the same rates as if it had been carried out by the contractor under the terms of his contract. The certificate of the Executive Engineer as to the costs and other allied expenses so incurred and as to the value of the work so done departmentally shall be final and conclusive against the contractor.

- (C) To order that the work of the contractor be measured up and to take such part thereof as shall be un-executed out of his hands, and to give it to another contractor to complete, in which case all expenses incurred on advertisement for fixing a new contracting agency, additional supervisory staff including the cost of work charged establishment and the cost of the work executed by the new contract agency will be debited to the contractor and the value of the work done or executed through the new contractor shall be credited to the contractor in all respects and in the same manner and at the same rates as if it had been carried out by the contractor under the terms of his contract. The certificate of the Executive Engineer as to all the cost of the work and other expenses incurred as aforesaid for or in getting the un-executed work done by the new contractor and as to the value of the work so done shall be final and conclusive against the contractor.

In case the contract shall be rescinded under Clause (a) above, the contractor shall not be entitled to recover or be paid any sum for any work therefore actually performed by him under this contract unless and until the Executive Engineer shall have certified in writing the performance of such work and the amount payable to him in respect thereof and he shall only be entitled to be paid the amount so certified. In the event of either of the courses referred to in Clause (b) or (c) being adopted and the cost of the work executed departmentally or through a new contractor and other allied expenses exceeding the value of such work credited to the contractors amount of excess shall be deducted from any money due to the contractor, by MCGM under the contract or otherwise, howsoever, or from his security deposit or the sale proceeds thereof provided, however, the contractor shall have no claim against MCGM even if the certified value of the work done departmentally or through a new contractor exceeds the certified cost of such work and allied expenses, provided always that whichever of the three courses mentioned in clauses (a), (b) or (c) is adopted by the Executive Engineer, the contractor shall have no claim to compensation for any loss sustained by him by reason of his having purchase or procured any materials or entered in to any engagements or made any advance on

account of or with a view to the execution of the work or the performance of the contract.

K. Contract may be rescinded and security deposit forfeited for bribing a public officer or if contractor becomes insolvent:

If the contractor assigns or sublets his contracts or attempt so to do, or become insolvent or commence any proceeding to get himself adjudicated and insolvent or make any composition with his creditors, or attempt so to do or if bribe, gratuity, gift, loan, perquisite, reward or advantage, pecuniary or otherwise, shall either directly or indirectly be given promised or offered by the contractor or any of his servants or agents through any public officer, or person in the employ of MCGM/Govt. in any way relating to his office or employment, or if any such officer or person shall become in any way directly or indirectly interested in the contract the Engineer In-charge may thereupon, by notice in writing rescind the contract and the Security Deposit of the Contractor shall thereupon stand forfeited and be absolutely at the disposal of MCGM and the same consequences shall ensure as if the contract had been rescinded under above clause J hereof; and in addition the contractor shall not be entitled to recover or be paid for any work therefore actually performed under the contract.

Submission of Tenders

PACKET – A

The Packet 'A' shall contain scanned certified copies of the following documents
Scrutiny of this packet will be done strictly with reference to only the scanned copies of Documents uploaded online in packet 'A'

- a) Valid Registration Certificate.
- b) Valid Bank Solvency Certificate of Minimum solvency amount as governed by Registration Rules in force for respective Class of Contractor for Civil and M&E works.
- c) A document in support of Registration under GST. Those not registered under GST shall submit an undertaking to the effect that if they are successful tenderer, they shall submit GST Certificate within 15 days of issue of work order, failing which payment for the work executed will not be released.
- d) Certified copies of valid 'PAN' documents and photographs of the individuals, owners, Karta of Hindu undivided Family, firms, private limited companies, registered co-operative societies, partners of partnership firms and at least two

Directors, if number of Directors are more than two in case of Private Limited Companies, as the case may be. However, in case of Public Limited companies, Semi Government Undertakings, Government Undertakings, no 'PAN' documents will be insisted.

- e) Latest Partnership Deed in case of Partnership firm duly registered with Chief Accountant (Treasury) of MCGM and registration certificate with registrar of companies in case of Private Ltd/Public Ltd/Semi Govt&Govt undertakings. The bidders shall categorically provide their Email-ID in packet 'A'.

NOTE:

- If the tenderer(s) withdraw tender offer during the tender validity period, his entire E.M.D shall be forfeited.
- If it is found that the tenderer has not submitted required documents in Packet "A" then, the shortfalls will be communicated to the tenderer through e-mail only and compliance required to be made within a time period of **three working days** otherwise they will be treated as non-responsive.

PACKET – B

The Packet 'B' shall contain scanned certified copies of the following documents –

- a) The list of similar type of works as stated in para 1.1. of post qualification successfully completed during the last 7 years in prescribed proforma, in the role of prime contractor. Information furnished in the prescribed proforma(Proforma-I) shall be supported by the certificate duly self attested. Documents stating that it has successfully completed during the last 7 years at least one contract of similar work as stated in para 1.1 of post qualification.
- b) Annual financial turnover for preceding three financial years as certified by Chartered Accountant preceding the Financial Year in which bids are invited. Copies of Applicants duly audited balance sheet and profit and loss account for the preceding three financial years preceding the Financial Year in which bids are invited.(Proforma – II)
- c) Documents stating that, it has access to or has available liquid assets, unencumbered assets, lines of credit and other financial means (independent

of any contractual advance payment) sufficient to meet the construction cash flow requirements for the subject contract in the event of stoppage, start-up, or other delay in payment of the minimum 15% of the cost of the work tendered for, net of the tenderer's commitment of other contracts (Certificate from Bankers / C.A./Financial Institution shall be accepted as a evidence).

- d) The bidder shall give undertaking on Rs 500/-stamp paper that it is his/their sole responsibility to arrange the required machineries either owned/on lease or hire basis, at site before start of the work.
- e) Details of works in hand (Proforma VI-A & VI-B) (original), along with copies of work orders & attested copies of percentage of works completed or part thereof.
- f) Statement showing assessed available Bid Capacity.
- g) The undertaking of Rs.500/- stamp paper as per the proforma annexed in 'Annexure B & C'
- h) The undertaking of Rs.500/- stamp paper as per the Annexure A (Irrevocable Undertaking) for compliance of provisions of G. S. T. Act.
- i) List of 'Technical Personnel with their qualification working in tenderers establishment (original). [Proforma IV]
- j) The bidder shall disclose the litigation history in Packet 'B' under the head "Details of Litigation History". If there is no Litigation History, the bidder shall specifically mention that there is no Litigation History against him as per the clause of Litigation History. In case there is Litigation History- Litigation History must cover – Any action of blacklisting, debarring, banning,suspension,deregistration and cheating with MCGM,State Govt., Central Govt. or any authority under state or Central Govt./ Govt. organisation initiated against the company, firm, directors, partners or authorized signatory shall be disclosed for last 5 years from the date of submission of bid. Also, bidder must disclose the litigation history for last 5 years from the date of submission of bid about any action like show cause issued, blacklisting, debarring, banning, suspension, deregistration and cheating with MCGM and MCGM is party in the litigation against the company, firm, directors, partners or authorized signatory for carrying out any work for MCGM by any authority of MCGM and the orders passed by the

competent authority or by any Court where MCGM is a party.

Note: Bidders shall submit the undertaking for equipment capability and other undertakings as such on a single Rs.500/- stamp paper.

- i)** The tenderer shall upload work plan as per the following outline:
1. GANTT chart/ PERT/ CPM chart showing the completion of work within prescribed time period, considering major activities.
 2. Organizational set up envisaged by the contractors.
 3. Plant & equipment proposed to be deployed for this work.
 4. Site Offices and Laboratories proposed to be set up.
 5. A note on how the whole work will be carried out (work plan including methodology).
 6. Quality management plan.
 7. All the activities included in the Scope of Work shall be covered in the work plan.
 8. Signed copies of all amendment's/corrigendum's if any.
 9. Information of Litigation history.

Note:

- i.** The Electrical / Mechanical work shall be got carried out by the civil contractors through the contractors registered with MCGM in class "B1 and above" of Electrical Category. Information about the registered contractors shall be obtained from the office of the Ch.E. (M&E)/ E.E. (Monitoring & Registration Cell). Attested scanned copy of the valid registration certificate in Electrical Category shall be uploaded with the tender along with the undertaking from the registered Electrical Contractor stating his willingness to carry out the tender work.
- ii.** The successful bidder shall submit valid registration certificate under E.S.I.C., Act 1948, if the tenderer has more than 10 employees /persons on his establishment (in case of production by use of energy) and 20 employees/persons on his establishment (in case of production without use of energy) to MCGM as and when demanded. In case of less employees/persons mentioned above then the successful bidder has to submit an undertaking to that effect on Rs. 500 stamp paper as per circular u/no. CA/FRD/I/65 of 30.03.2013.

- iii.** The successful bidder shall submit valid registration certificate under E.P.F. & M.P., Act 1952, if tenderer has more than 20 employees/persons on his establishment, to MCGM as and when demanded. In case if the successful bidder has less employees/persons mentioned above then the successful bidder has to submit an undertaking to that effect on Rs. 500 stamp paper as per circular u/no. CA/FRD/I/44 of 04.01.2013.

Note:

- If it is found that the tenderer has not submitted required documents in Packet “B” then, the shortfalls will be communicated to the tenderer through e-mail only and compliance required to be made within a time period of **three working days** otherwise they will be treated as non-responsive.

PACKET – C

- a. Online tender filled in either percentage plus or minus (above or below), or at par. (There is no separate provision to quote % in physical form, this is a part in Header Data of online Tendering). For Packet ‘C’ tenderer(s) will fill data in ‘Item Data Tab’ in Service Line Item via Details and quotes his percentage variation figures. **(If entered ‘0’ it will be treated as ‘at par’**. By default the value is zero only).

Note: In case of rebate/premium of 15% and above as quoted by the tenderer, the rate analysis of major items shall be submitted by L1 and L2 bidder after demand notification by e-mail to bidders by concerned Dy.Ch.Eng. The format for rate analysis is annexed at Annexure D.

BID SECURITY OR EMD

- The Bidder shall furnish, as part of the Bid, Bid Security/EMD, in the amount specified in the Bid Data Sheet. This bid security shall be in favour of the authority mentioned in the Bid Data Sheet and shall be valid till the validity of the bid.
- The tenderers shall pay the EMD online instead paying the EMD at any of the CFC centres in MCGM Ward Offices.

- Any bid not accompanied by an acceptable Bid Security and not secured as indicated in sub-clause mentioned above, shall be rejected by the Employer as non-responsive.
- The Bid Security of the successful Bidder will be discharged when the Bidder has signed the Agreement and furnished the required Security Deposits.
- The Bid Security/ EMD of L2 and other higher bidders (L-3, L4 etc.) shall be refunded immediately after opening of financial bid.
- In case, the successful bidder becomes non-responsive or successful bidder withdraws the bid or is un-willing to extend the bid validity period, in such circumstances, if L2 bidder is agreeable to extend the bid validity period and ready to deposit the requisite amount of bid security/EMD and ASD to the department within the stipulated time period i.e. 15 days, the department will process further as per normal procedure.
- The Bid Security may be forfeited:
 - a) if the Bidder withdraws the Bid after bid opening (opening of technical qualification part of the bid during the period of Bid validity;
 - b) in the case of a successful Bidder, if the Bidder fails within the specified time limit to:
 - i. sign the Agreement; and/or
 - ii. Furnish the required Security Deposits.
- 1. The cases wherein if the shortfalls are not complied by a contractor, will be informed to Registration and Monitoring Cell. Such non-submission of documents will be considered as 'Intentional Avoidance' and if three or more cases in 12 months are re-reported, shall be viewed seriously and disciplinary action against the defaulters such as banning/de-registration, etc. shall be taken by the registration cell with due approval of the concerned AMC.
- 2. No rejections and forfeiture shall be done in case of curable defects. For non-curable defects the 10% of EMD shall be forfeited and bid will be liable for rejection.
 - i) Curable Defect shall mean shortfalls in submission such as:

- a. Non-submission of following documents,
 - i. Valid Registration Certificate
 - ii. Valid Bank Solvency
 - iii. GST Registration Certificate (GST)
 - iv. Certified Copies of PAN documents and photographs of individuals, owners, etc
 - v. Partnership Deed and any other documents
 - vi. Undertakings as mentioned in the tender document.
 - vii. Litigation History

- ii) Non-curable Defect shall mean
 - a. Inadequate submission of EMD amount.
 - b. Inadequacy of technical and financial capacity with respect to Eligibility criteria as stipulated in the tender.
 - c. Wrong calculation of Bid Capacity,
 - d. No proper submission of experience certificates and other documents, etc.
 - e. Non- Submission of Rate Analysis within 3 days of opening of Packet-C.

BID VALIDITY

- Bids shall remain valid for a period of not less than **one hundred eighty (180) days** after the deadline date for bid submission specified in Bid Data Sheet. A bid valid for a shorter period shall be rejected by the Employer as non-responsive.

- In exceptional circumstances, prior to expiry of the original time limit, the Employer may request that the bidders may extend the period of validity for a specified additional period. The request and the bidders' responses shall be made in writing or by cable. A bidder may refuse the request without forfeiting his Bid Security. A bidder agreeing to the request will not be

required or permitted to modify his bid, but will be required to extend the validity of his bid security for a period of the extension.

DEFECT LIABILITY PERIOD

- The Contractor is expected to carry out the construction work in Workmen like manner so as to meet the requirement and specification for the project. It is expected that the Workmanship and materials will be reasonably fit for the purpose for which they are required.
- Defects or defective work is where standard and quality of workmanship and materials as specified in the contract is deficient. Defect is defined as a failure of the completed project to satisfy the express or implied quality or quantity obligations of the construction contract. Defective construction works are as the works which fail short of complying with the express descriptions or requirements of the contract, especially any drawings or specifications with any implied terms and conditions as to its quality, workmanship, durability, aesthetic, performance or design. Defects in construction projects are attributable to various reasons.
- Some of the defects are structural defects results in cracks or collapse of faulty defective plumbing, inadequate or faulty drainage system, inadequate or faulty ventilation, cooling or heating systems, inadequate fire systems etc. The defects could be various on accounts of different reasons for variety of the projects.
- The Engineering In charge/Project Officer shall issue the practical completion certificate for the project. During the Defect Liability Period which commences on completion of the work, the Engineering In charge shall inform or the contractor is expected to be informed of any defective works by the Employer's representative of the defects and make good at contractor's cost with an intention of giving opportunity to the contractor of making good the defects appeared during that period. It is the contractor's obligation under the contract to rectify the defects that appear during Defect Liability Period and the contractor shall within a reasonable time after receipt of such instructions comply with the same at his own cost. The Engineering In

charge/Project Officer shall issue a certificate to that effect and completion of making good defects shall be deemed for all the purpose of this contract to have taken place on the day named in such defect liability certificate.

- If defective work or workmanship or design have been knowingly covered-up or concealed so as to constitute fraud, commencement of the Defect Liability Period may be delayed. The decided period may be delayed until **discover** actually occurs on at least the defect could have been discovered with reasonable diligence, whichever is earlier.
- The DLP shall be as below:

Sr. No.	Description of work	Defect Liability Period
1	General works	3 years
2	Structural works	5 years
3	Waterproofing works	5 years

- Also, in case of defect, the Engineer shall give notice to the Contractor of any Defects before the end of the Defects Liability Period, which begins at. The Defects Liability Period shall be extended for as long as Defects remain to be corrected. Every time notice of Defect/Defects is given, the Contractor shall correct the notified Defect/Defects within the duration of time specified by the Engineer's notice. The Engineer may issue notice to the Contractor to carry out removal of defects or deficiencies, if any, noticed in his inspection, or brought to his notice. The Contractor shall remove the defects and deficiencies within the period specified in the notice and submit to the Engineer a compliance report.
- It is the Completion Stage when the contractor has completed all of the works and fixed all of the defects that were on the list of issue by Engineer-in-charge. When this happens, the engineer must issue a 'Certificate of Completion'. On the issue of 'Certificate of Completion', the 'Defect Liability Period' starts. The contractor also must issue a 'Certificate statement' as an acknowledgment to the engineer not later than 14 days after the 'Certificate of Completion' has been issued. During the 'Defect Liability Period', the contractor has to obey all written instructions from the engineer to carryout

repairs and fix any defects which appear in the Permanent Works. If the contractor does not, due to his own faults finish the repair works or fix the defects by the end of 'Defect Liability Period', the 'Defect Liability Period' will continue until all works instructed by engineer is done.

SECURITY DEPOSIT AND PERFORMANCE GUARANTEE

A. Security Deposit

The security deposit shall mean and comprise of

I) Contract Deposit and

II) Retention Money.

I) **Contract Deposit** – The successful tender, here after referred to as the contractor shall pay an amount equal to **two (2)** percent of the contract sum shall be paid within thirty days from the date of issue of letter of acceptance.

II) **Retention Money** – The contractor shall pay the retention money an amount equal to Five **(5)** percent of the Contract Sum which will be recovered from the contractors every bill i.e. interim / running / final bill. As per CA(F) prevailing circular Un/No. CA(F)/P/21 dtd. 07.09.2020. The clause of retention money will not be applicable M. & E. Department.

B. Additional Security Deposit

New Condition For Additional Security Deposits as per Circular No.

प्रले (वित्त)/४२दिनांक०९.०२.२०२१ is applicable for this tender.

Calculation Of Additional Security Deposits is as below

The **additional security deposit** will be applicable when a rebate of more than of 12 % at the rate of with no maximum limit. The ASD is calculated as follows:

Additional security deposit = $(X/100) \times$ office estimated cost,

Where X=percentage rebate quoted above 12%

C. Performance Guarantee

The successful tender, here after referred to as the contractor shall pay in the form of “Performance Guarantee” at different rates for different slabs as stated below:

Offer	PG applicable %
For premium, at par and rebate 0 to 12%	PG= 0.92% x contract sum applicable for rebate of 12%
For rebate of 12.01% and more.	P.G. = {0.92% x contract sum applicable for rebate of 12%} +(X) x contract sum Where, X= percentage rebate quoted more than 12%

Note: Contract sum shall mean amount after application of rebate/premium as quoted by the contractor with contingencies only and excluding price variation.

The PG shall be paid in one the following forms.

- I) Cash (In case guarantee amount is less than Rs.10, 000/-
- II) Demand Draft (In case guarantee amount is less than Rs.1, 00,000/-
- III) Government securities
- IV) Fixed Deposit Receipts (FDR) of a Schedule Bank.
- V) An electronically issued irrevocable bank guarantee bond of anyscheduled bank or f in the prescribed form given in Annexure.

Performance Guarantee is applicable over and above the clause of Security Deposit. Performance Guarantee will have to be paid & shall be valid till the defect liability period or finalization of final bill whichever is later.

This deposit will be allowed in the form of I to V as mentioned above and shall be paid within 15 days after receipt of Letter of Acceptance.

Note: Following exceptions shall be adopted for ‘Demolition Tenders’:

- Irrespective of the offer (Rebate/ at par/ premium), ASD shall be differed and only PG of 10% of contract sum be taken from the successful bidder on award of contract only.
- MCGM departments shall ensure to incorporate specific condition regarding above in bid document and e-tender notice.

D. Refund of Security Deposit

I. Refund of Contract Deposit

The Contract Deposit shall be released within 30 days after completion of 3rd year of DLP (in case of 5 years DLP) and after issue of 'Defect Liability Certificate' (in case of 1 or 2 or 3 years DLP) subject to no recoveries are pending against the said work, provided that the Engineer is satisfied that there is no demand outstanding against the Contractor. No claim shall be made against the Balance Contract Deposit after the issue of Defects Liability Certificate.

II. Refund of Retention Money

One-half (50%) of the Retention Money shall be released within 30 days of issue of 'Certificate of Completion' with respect to the whole of the Works. In the event the Engineer issues a Taking-over Certificate for a section or part of the Permanent Works, only such proposition thereof as the Engineer determines (having regard to the relative value of such section or part of the Works) shall be considered by the Engineer for payment to the Contractor.

The balance Retention Money shall be released within 30 days after completion of 3rd year of DLP (in case of 5 years DLP) and after issue of 'Defect Liability Certificate' (in case of 1 or 2 or 3 years DLP) provided that the Engineer is satisfied that there is no demand outstanding against the Contractor. In the event of different Defects Liability Periods have been specified or become applicable to different sections or parts of the Permanent Works, the said moneys will be released within 30 days on expiration of the latest of such Defects Liability Periods.

Payment of the above mentioned 50% is exclusive of the amounts to be withheld as stated in and that amount shall be paid as per condition stated therein.

III. Refund of Additional Security Deposit

The additional security deposit shall be released within 30 days of issue of 'Certificate of Completion' with respect to the whole of the Works. In the event the Engineer issues a Taking-over Certificate for a section or part of the Permanent Works, only such proposition thereof as the Engineer determines (having regard to the relative value of such section or part of the Works) shall be considered by the Engineer for payment to the Contractor.

IV. Refund of Performance Guarantee

The Deposit on account of performance guarantee shall be released within 30 days of completion of Defects Liability Certificate subject finalization of final bill whichever is later and no recoveries are pending against the said work, provided that the Engineer is satisfied that there is no demand outstanding against the Contractor.

➤ Summary of time of Refund of deposit is tabulated as follows:

a) Time of Refund for works having 5 years DLP

Deposits refunded after completion	After 3 yrs of DLP	After Completion of DLP
ASD + 50% of RM	CD+50% of RM	PG

b) Time of Refund for works having 1 or 2 or 3 years DLP

Deposits refunded after completion	After Completion of DLP
ASD + 50% of RM	CD+50% of RM+PG

*Note:

- a) It shall be clearly mentioned that the BG shall be applicable for individual work/contract and clubbing of various contracts of the said contractor will not be allowed. In case of obtaining Bank Guarantee, it is necessary to mention that the same shall be valid further 6 months from the completion of defect liability period/ warranty period.
- b) It shall be the responsibility of the bidder to keep the submitted B.G. "VALID" for the stipulated time period in the tender & in case of its expiry it will attract penalization.
- c) Bank Guarantee should be issued by way of General Undertaking and Guarantee issued on behalf of the Contractor by any of the Nationalized or Scheduled banks or branches of foreign banks operating under Reserve Bank of India regulations located in Mumbai up to Virar & Kalyan. List of approved Banks is appended at the end of Instructions to Bidders (ITB). The Bank Guarantee issued by branches of approved Banks beyond Kalyan and Virar can be accepted only if the said Bank Guarantee is countersigned by the Manager of a Regional Branch of the same bank within the Mumbai City Limit categorically endorsing thereon that the said Bank Guarantee is binding on the endorsing Branch of the Bank or the Bank itself within Mumbai Limits and is liable to be enforced against the said Branch of the Bank or the bank itself in case of default by the Contractors furnishing the Bank Guarantee. The Bank Guarantee shall be renewed as and when required and/or directed from time to time until the Contractor has executed and completed the works and remedied any defects therein.

E. Legal + Stationary Charges: (As per applicable circular)

Successful tender shall pay the Legal Charges + Stationary charges as per Circular no. 10318 dtd. 24.03.2022

Contract Value						Legal + Stationary Charges	
upto	Rs.	10,001/-	T0	Rs.	50,000/-	Rs.	Nil

from	Rs.	50,001/-	To	Rs.	1,00,000/-	Rs.	6290/-
from	Rs.	1,00,001/-	To	Rs.	3,00,000/-	Rs.	10380/-
from	Rs.	3,00,001/-	To	Rs.	5,00,000/-	Rs.	12470/-
from	Rs.	5,00,001/-	To	Rs.	10,00,000/-	Rs.	14510/-
from	Rs.	10,00,001/-	To	Rs.	20,00,000/-	Rs.	16570/-
from	Rs.	20,00,001/-	To	Rs.	40,00,000/-	Rs.	18660/-
from	Rs.	40,00,001/-	To	Rs.	1,00,00,000/-	Rs.	20720/-
from	Rs.	1,00,00,001/-	To	Rs.	10,00,00,000/-	Rs.	24450/-
from	Rs.	10,00,00,000/-	To	Rs.	20,00,00,000/-	Rs.	28220/-
from	Rs.	20,00,00,000/-	To	Rs.	30,00,00,000/-	Rs.	31980/-
from	Rs.	30,00,00,000/-	To	Rs.	40,00,00,000/-	Rs.	35740/-
from	Rs.	40,00,00,000/-	To	Rs.	50,00,00,000/-	Rs.	39470/-
from	Rs.	50,00,00,000/-	To	Rs.	100,00,00,000/-	Rs.	47000/-
from	Rs.	100,00,00,000/-	To	Rs.	200,00,00,000/-	Rs.	58270/-
from	Rs.	200,00,00,000/-	To	Rs.	300,00,00,000/-	Rs.	65770/-
from	Rs.	300,00,00,000/-	To	Rs.	400,00,00,000/-	Rs.	75120/-
from	Rs.	400,00,00,000/-	To	Rs.	500,00,00,000/-	Rs.	84510/-
from	Rs.	500,00,00,000/-	To	Rs.	Up to Any Limit	Rs.	93920/-

requested to note that stationary charges as given in the table above will be recovered from the successful tenderer for supply of requisite prescribed forms for preparing certificate bills in respect of the work.

F. Stamp Duty: (As per applicable circular)

It shall be incumbent on the successful tenderer to pay stamp duty on the contract.

- (i) As per the provision made in Article 63, Schedule I of Bombay Stamp Act 1958, stamp duty is payable for “works contract” that is to say, a contract for works and labour or services involving transfer of property in goods (whether as goods or in some other form) in its execution and includes a sub-contract, as under :

(a)	Where the amount or value set forth in such contract does not exceed rupees ten lakh.	Five Hundred rupees stamp duty
(b)	Where it exceeds rupees ten lakhs.	Five hundred rupees plus 0.1% of amount above rupees subject to the maximum of rupees twenty five lakh stamp duty.
(c)	Stamp duty on BG equal to 0.5% of the BG Amount.	

- ii. The successful bidder shall enter into a contract agreement with M.C.G.M. within 30 days from the date of issue of Work Order and the same should be adjudicated for payment of Stamp Duty by the successful bidder.
- iii. Further shortfall if any, in amount of stamp duty paid as against prescribed amount for the documents executed in Mumbai City & Mumbai Suburban District be recovered from the concerned work contractors and to deposit the deficit or unpaid Stamp Duty and penalty by two separate Demand Draft or Pay Order in favour of “Superintendent of Stamp, Mumbai” within 15 days from intimation thereof.
- iv. All legal charges and incidental expenses in this respect shall be borne and paid by the successful tenderer.

IMPORTANT DIRECTIONS

1. All the information uploaded shall be supported by the corroborative documents in absence of which the information uploaded will be considered as baseless and not accepted for qualification criteria. All the documents shall be uploaded with proper pagination. The page No. shall be properly mentioned in the relevant places.

The information shall be uploaded in the sequence as asked for with proper indexing etc. The Bidder shall be fully responsible for the correctness of the information uploaded by him.

2. Applicants/Bidders shall refer portal.mcgm.gov.in\tenders for “The Manual of Bid-Submission for Percentage Rate/Item Rate Tender Document.” The detail guidelines for creation and submission of bid are available in the referred document. Any queries or request for additional information concerning this TENDER shall be submitted by e-mail to pk.mcgm@yahoo.com. The subject shall clearly bear the following identification/ title: "Queries/ Request for Additional Information: TENDER for “Major Structural Repairs to Municipal Buildings known as 50 Tenements & 72 tenements at Peru Chawl, Gas Company Lane, Lalbaug in F/South ward.” Any changes in mail ID will be intimated on the portal.

3. In case of **Equal Percentage** of lowest bidders (L1), the allotment of work shall be done by giving 48 hrs (**2 working days**) from the day of opening of packet C **on same BID-Document number for re-quoting** and such development needs to be done by IT department in MCGM’s SRM system. **Till such development is made; ‘Sealed Bids’ shall be called from the bidders quoting the same rates i.e. L1.**

In case of equal percentage of lowest bidders is obtained even after re-quoting, then the successful bidder will be decided by lottery system by concerned Chief Engineer.

The bidder shall need to submit the additional ASD if applicable within 15 days after receipt of LOA by concerned Chief Engineer. If ASD is not submitted within 15 days, EMD will be forfeited, company will be debarred for 2 years also other companies with same partner/ directors will be debarred for 2 years.

Also, the Performance Guarantee shall be paid in 15 days after receipt of Letter of Acceptance.

SECTION 7
SCOPE OF WORK

Scope of work:

Proposed work comprises of

1. Structural Repairs by using P. M. M., Micro-concrete and RCC work wherever required.
2. WPT works to terrace, WC, Bath, OHWT and chajja.
3. Internal plaster for common area & for the rooms wherever required.
4. External plaster.
5. Internal & external painting.
6. Kota flooring for common area, Kota Riser & tread, Ceramic flooring & Dado work wherever required.
7. Provisional Qty. of Structural steel and providing MS railing.
8. Masonry works
9. Other ancillary work such as Anti- termite treatment, FRP doors, plumbing & sanitation work, dismantling & demolition work etc. and necessary electrification work.

SECTION 8

Measurement Sheet (Civil)

MEASUREMENT SHEET for 50 Tenaments, Peru Chawl, Lalbaug in F/South Ward									
Sr No	ITEM CODE	ITEM DESCRIPTION	No.	L (m)	B (m)	H (m)	Qty	Total Qty	Unit
1	R2-CS-PL-16-c	External Plaster							
		back side	1	61.31		15.3	938.04		
		Sides of Building	2	7.4		15.3	226.44		
		Chajja	50	1.4		0.6	42.00		
		Chajja sides	50	2.6		0.1	13.00		
		Deduction windows	-50	1.5		1.5	-112.50		
			-50	0.6		0.9	-27.00		
		Front sides	2	2.5		13.3	66.50		
			1	2.3		13.3	30.59		
		Overhead water tank	3	23.4		2.6	182.52		
			4	7.70		4	123.20		
		Additional column plaster	10	4.00		1	40.00		
		Pump Room	2	16.00		3	96.00		
							1618.79		
		say					1620.00	1620.00	Sq.M
2	R2-CS-PL-09-c	Internal Plaster							
		Hall	2	3.6	2.90		20.88		
			2	3.5	2.90		20.30		
		less door	-1	0.9	2.1		-1.89		
		less window	-1	1	1.2		-1.20		
		Balcony/Kitchen	2	2.3	2.9		13.34		
			2	2.5	2.9		14.50		
		less door	-1	0.9	2.1		-1.89		
		less window	-1	1.5	1.5		-2.25		
		Balcony	2	1.57	2.9		9.11		
			2	1.3	2.9		7.54		
		less door opening	-1	0.9	2.1		-1.89		
							76.55		
		for 25 rooms					1913.65	A	
		say 50% qty					956.83	A'	
		Passage Area							
		Main wall	5	40	2.9		580.00		

		Pardi wall	10	40	0.3		120.00		
		wall top side	10	40	0.1		40.00		
		Staircase wall	2	3.6	15		108.00		
			2	2.4	15		72.00		
		less staircase opening	-5	2.4	2.9		-34.80		
		less doors	-50	0.9	2.1		-94.50		
		less windows	-50	0.9	1.1		-49.50		
							741.20	B	
		Say 50% qty					370.60	B'	
						Total A'+B'	1327.43		
		For painting				A + B	2654.85		
		say					2660.00	C	
						Say	1330.00	1330.00	Sq.M
3	R2-CS-PL-05	Ceiling Plater							
		Hall	1	3.6	3.5		12.60		
		Balcony/Kitchen	1	2.3	2.5		5.75		
		Bed	1	1.57	1.3		2.04		
		loft ceiling	1	1.2	1.3		1.56		
		Bath	1	1.2	2.8		3.36		
		WC	1	1.25	0.1		0.13		
		loft ceiling	1	2.8	2.4		6.72		
							32.16		
		For 25 Rooms					803.90	A	
		say 50 % qty					401.95	A'	
		Passage							
		ceiling	5	40	1.15		230.00		
		beam	5	40	0.4		80.00		
		staircase landing	4	2.4	1		9.60		
		staircase waist slab	10	1	3.6		36.00		
		pardi	20	0.9	3.6		64.80		
		head room	1	2.4	3.6		8.64		
							429.04	B	
		say 50% qty					214.52	B'	
						Total A'+B'	616.47		
		for painting				A + B	1232.94		

		say					1235.00	C	
						say	620.00	620.00	Sq.M
4	R2-CS-PL-25	Extra over plaster					405.00		
		25% of Qty as item no R2-CS-PL-16-c				say	425.00	425.00	Sq.M
5	R2-CS-WP-39	water proofing to toilet /baths							
		Bath	20	1.2	1.9		45.60		
		W/C	20	1	1.2		24.00		
							69.60		
		say					70.00	70.00	Sq.M
6	R2-CS-WP-17	Terrace waterproofing							
		Terrace	1	40.00	8.95		358.00		
		Front Passage	1	40.00	1.25		50.00		
		Water tank top	2	4.00	7.70		61.60		
							469.60		
						Say	470.00	470.00	Sq.M
7	R2-CS-WP-34	Providing water proofing treatment to existing RCC overhead tank							
		OHWT							
		sides	2	7.70		2.60	40.04		
			2	4.00		2.60	20.80		
		bottom	1	7.70		4.00	30.80		
		Provisional qty for under ground water tank					50.00		
							141.64		
						say	150.00	150.00	Sq.m
8	R2-CS-WP-44	Water proofing treatment to the chajja							
		chajja	50	1.50	0.60		45.00		
						Say	50	50.00	Sq.m
9	R2-CS-CW-1-a	Providing and laying in position plain cement concrete Nominal Mix of 1:1.5:3 (1 cement OPC: 1.5 coarse sand : 3 graded stone aggregate 20 mm nominal size)							
		for plinth protection							
		front	1	39.31	1.00	0.1	3.93		

		sides	2	8.5	1.00	0.1	1.70		
		back	1	39.31	1.00	0.1	3.93		
							9.56		
						Say	10	10.00	Cu.m
10	R2-CS-CW-7-d	M-20 Concrete (coping) Lintels, beams, plinth beams, girders, floor beam, coping							
		Coping	1	97.4	0.35	0.1	3.41		
		Provisional qty for lintels					3.00		
							6.41		
						Say	7.00	7.00	Cu.m
11	R2-CS-CW-7-c	Slabs, Suspended floors, roofs, landings, balconies, canopy and access platform							
		provisional qty for slabs					5.00		
						Say	5	5.00	Cu.m
12	R2-CS-CW-7-b	Walls (any thickness)							
		provisional qty for RCC parris					10.00		
						say	10.00	10.00	Cu.m
13	R2-CS-CW-35-c	Reinforcement							
							1.00	1.00	MT
14	R2-CS-CW-45	Microconcrete							
							1000.00	1000.00	Kg
15	R2-CS-CW-56	PMM 15 mm							
							800.00	800.00	Sqm
16	R2-CS-CW-55	Removing corrosion of steel							
							1100.00		
							1100.00	1100.00	Sqm
17	R2-CS-CW-57	PMM 30 mm							
							300.00	300.00	Sqm

	R2-CS-SS-07	Providing and fixing the Chemical Anchor Fasteners							
18	R2-CS-SS-07-a	M10 x 90 foil capsule (HVU) & M10 x 130 Rod					100.00	100.00	No
19	R2-CS-SS-07-b	M12 x 110 foil capsule (HVU) & M12 x 160 Rod					20.00	20.00	No
20	R2-CS-MW-4-b	Brick Work							
		Provisional qty for rooms and parapet walls					10.00		
						say	10.00	10.00	Cum
21	R2-CS-PN-4-a	Internal oil paint							
		Internal Plaster					2660.00		
		Ceiling Plaster					1235.00		
							3895.00		
							3895.00	3895.00	Sq.M
22	R2-CS-PN-12-a	External Paint							
		Quantity is same as per item No.- R2-CS-PL-16-c					1620.00		
							1620.00	1620.00	Sq.M
23	R2-CS-PN-4-b	Paint for wood work							
		Doors	50	0.9	2.1		94.5		
		Windows	50	1	1.2		60		
							154.50		
						say	160.00	160.00	Sq.M
24	R2-CS-PN-4-c	Paint for steel work					100.00		
							100.00	100.00	Sq.M
25	R2-CS-PN-15	Extra over paint							
		Assume 25% quantity of item No. CS-PN-12-a					405.00		
						say	425.00	425.00	Sq.m
26	R2-CS-FL-01-c	Kota flooring							
		Kota flooring							
		Passage	5	40	1.15		230.00		
		Landing	4	2.4	1		9.60		
		staircase room	1	2.4	2.3		5.52		

							245.12		
		50 % qty					122.56		
						say	125.00	125.00	Sq.M
27	R2-CS-FL-07-c	Ceramic flooring antiskid							
		WC	20	1	1.2		24.00		
		Bath	20	1.2	1.9		45.60		
							69.60		
						say	70.00	70.00	Sq.M
28	R2-CS-FL-31-a	Dado							
		Bath	2	1.2	1.8		4.32		
			2	1.9	1.8		6.84		
		less door	-1	0.75	1.8		-1.35		
		less louvers	-1	0.5	0.8		-0.40		
		WC	2	1	2.1		4.20		
			2	1.25	2.1		5.25		
		less door	-1	0.75	1.8		-1.35		
		less Louvers	-1	0.5	0.8		-0.40		
							17.11		
							34.22		
		For 20 Toilet /Bath					684.40		
		Say				say	670.00	670.00	Sqm
29	R2-CS-FL-21-d	Risers							
		50% qty	40	1			40.00		
							40.00	40.00	Rmt
30	R2-CS-FL-38-d	Treads							
		50% qty	40	1			40.00		
							40.00	40.00	Rmt
31	R2-CS-FL-40-e	150 mm green marble							
		for the sides of doors of toilet and bathroom							
		Bath and wc	40	5.1			204		
							204	204	Rmt

32	R2-CS-FL-40-p	18mm thk. green marble for width upto 300 mm							
		Provisional					50		
							50	50	Rmt
33	R2-CS-FL-8-a	Vitrified flooring							
		provisional qty for rooms					100	100	Sqm
34	R2-CS-EW-1	Excavation							
		Plinth Protection							
		front	1	39.31	1.00	0.3	11.79		
		Back Side	1	39.31	1.00	0.3	11.79		
		sides	2	8.5	1.00	0.3	5.10		
							28.69		
							say	30.00	30.00
									Cu.m
35	R2-CS-EW-26	Soling							
		Plinth Protection							
		front	1	39.31	1.00	0.23	9.04		
		Back Side	1	39.31	1.00	0.23	9.04		
		sides	2	8.5	1.00	0.23	3.91		
							21.99		
							say	25.00	25.00
									Cu.m
36	R2-CS-DD-2	Demolishing R.C.C.							
		Provisional qty					5.00		
							say	5.00	5.00
									Cu.m
37	R2-CS-DD-3	Demolishing brick work							
		qty as per item no R2-CS-MW-4-b					20.00		
							20.00	20.00	Cu.m
38	R2-CS-DD-37-a	Dismantling C.I., UPVC							
		Removing drain pipes (Soil Waste Water)							
		75-80 mm dia pipe					200.00		
							say	200.00	200.00
									R.m
39	R2-CS-DD-37-b	Dismantling C.I., UPVC							
		Removing drain pipes (Soil Waste Water)							
		100 mm dia pipe					300.00		

							300.00	300.00	R.m
40	R2-CS-DD-56	Removing any existing water proofing							
			50	1.5	0.6		45.00		
							45.00	45.00	Sq.m
41	R2-CS-DD-64	Removing flooring							
		Qty as per item No. R2-CS-FL-1-c					125.00		
		Qty as per item No. R2-CS-FL-7-c					90.00		
		Qty as per item No. R2-CS-FL-21-d (40 x 0.15)					6.00		
		Qty as per item No. R2-CS-FL-31-a					670.00		
		Qty as per item No. R2-CS-FL-38-d (40 x 0.25)					10.00		
		Qty as per item No. R2-CS-FL-40-e (204 x 0.15)					30.60		
		Qty as per item No. R2-CS-FL-40-p (50 x 0.30)					15.00		
		Qty as per item No. R2-CS-FL-8-a					100.00		
							1046.60		
							1050.00	1050.00	Rmt
42	R2-CS-DD-38-a	Dismantling GI pipes							
		Qty as per R2-CS-PS- 90-a ,c,d					500.00	500.00	Rmt
		Qty as per R2-CS-PS- 90-f							
43	R2-CS-DD-65	Removing cement plaster							
		Qty as per item no R2-CS-PL-16-c					1700.00		
		Qty as per item no R2-CS-PL-9-c					1330.00		
		Qty as per item no R2-CS-PL-5					620.00		
							3650.00		
						say	3650.00	3650.00	Sq.M
44	R2-CS-DD-79	Removing soil pan,					20.00		
							20.00	20.00	EA
45	R2-CS-DD-70	Removing and refixing existing door or window							
		Provisional					20.00	20.00	Nos

46	R2-CS-AT-2	Providing anti-termite treatment							
			1	100			100.00		
							100.00	100.00	Rm
		Provisional quantity per building (for wall etc)							
47	R2-CS-AW-04	aluminum louvered window	20	0.5	0.8		8.00	8.00	Sqm
48	R2-CS-SL-12-c	Providing and Fixing MS Safety grill							
		for louvers	25	0.6	0.9		13.5		
		provisional qty for windows	10	1.8	1.8		32.4		
							45.9		
		say					50.0	50.0	Sqm
49	R2-CS-PV-02	Providing and fixing to frames 30 mm thick							
		WC	20	0.75	1.8		27.00		
		Bath	20	0.75	1.8		27.00		
		Tercae Doors	1	0.8	1.8		1.44		
							55.44		
		Say					60.00	60.00	Sq.m
50	R2-CS-SS-32	Providing & fixing S.S. pipe hand rail							
			1	30			30.00		
							30.00	30.00	Mtr
51	R2-CS-PS-13-b	Providing and fixing white vitreous china water closet squatting pan (Indian type) Orissa pattern W.C. pan of size 580x440 mm	10				10.00	10.00	EA
52	R2-CS-PS-2-a	Providing and fixing white vitreous china pedestal type water closet (European type W.C. pan)	10				10.00	10.00	Ea
53	R2-CS-PS-87-a	CPVC pipes 15mm							
							150.00	150.00	Rmt
54	R2-CS-PS-87-b	CPVC pipes 20mm							
							100.00	100.00	Rmt
55	R2-CS-PS-87-c	CPVC pipes 25 mm							

						100.00	100.00	Rmt
56	CS-PS-59-b-2	Providing and fixing trap of self cleansing design				20.00	20.00	EA
57	R2-CS-PS-192	Providing and fixing in position uPVC/SWR (Soil/Waste/Rain) pipe of type-B 110 mm						
		qty as per item no R2-CS-DD-37-b				300.00	300.00	Rmt
58	R2-CS-PS-191	Providing and fixing in position uPVC/SWR pipe 75 mm dia.						
		qty as per item no R2-CS-DD-37-a				200.00	200.00	Rmt
59	R2-CS-PS-163-b	Providing, laying and jointing glazed stoneware pipes 150 mm diameter						
			1	60		60.00	60.00	Rmt
60	R2-CS-PS-166-b-1	Providing and fixing square-mouth S.W. gully trap						
						10.00	10.00	Each
61	R2-CS-PS-194	Constructing brick masonry inspection chamber 90cm x 45cm x30cm						
			15			15.00	15.00	Rmt
62	R2-CS-PS-196	Providing & fixing M. S. angled ISA 5050 of 6 mm. welded frame						
			10			10.00	10.00	Each
63	R2-CS-PS-167-b	Dismantling of old S.W. pipes						
			1	60		60.00	60.00	Rmt
64	R2-CS-PS-90-a	15 mm GI pipes		150		150.00	150.00	Mtr
65	R2-CS-PS-90-c	25mm GI pipes		100		100.00	100.00	Mtr
66	R2-CS-PS-90-d	32mm GI pipes		150		150.00	150.00	Mtr

67	R2-CS-PS-90-f	50mm GI pipes		100			100.00	100.00	Mtr
68	R2-CS-PS-93-a	Providing and fixing brass bib cock of approved quality :15 mm nominal bore		25			25.00	25.00	Each
69	R2-CS-SS-01	Structural steel							
		Provisional qty					1.00	1.00	MT
70	R2-CS-AW-01	Providing and fixing in position two track aluminum window							
		Kitchen/ balcony windows	10	1.5	1.5		22.50		
						say	25.00	25.00	Sqm
71	R2-RW-3-17	Providing and fixing 60 mm thick lacquer							
		front	1	40	1.00		40.00		
		Back Side	1	40	1.00		40.00		
		sides	2	8.7	1.00		17.40		
							97.40		
						say	100.00	100.00	Sqm
72	R2-RW-3-14	Removing and refixing 60 mm thick pavers							
		provisional qty					200.00	200.00	Sqm
73	R2-CS-RM-95	FRP chajja							
		provisional qty in chajja demolish					20.00		
							20.00	20.00	Sq.m
74	R2-CS-WW-05	Flush door							
		Provisional					20.00	20.00	Sqm
75	R2-CS-PN-14	Extra over paint							
		Qty as per item no R2-CS-PN-3 toR2-CS-PN-6					3895.00	3895.00	Sqm
76	R2-SWD-147	Supplying and fixing 0.90m x 0.45m internal size of rectangular C.I. air tight cover and frame							
			5				5.00	5.00	Each
77	R2-CS-RW-08	Polycarbonate corrugated sheets							
		front side chajja	5	40	0.8		160.00		
			10	2.5	0.8		20.00		
							180.00	180.00	Sqm

Sd/-

S.E. (B.M.) F/S

Sd/-

A.E.(B.M.) City

Sd/-

E.E. (B.M.) City- II

MEASUREMENT SHEET for 72 Tenaments, Peru Chawl, Lalbaug in F/South Ward									
Sr No	ITEM CODE	ITEM DESCRIPTION	No.	L (m)	B (m)	H (m)	Qty	Total Qty	Unit
		Front sides	1	35.31		18.3	646.17		
		back side	1	35.31		18.3	646.17		
		Sides of Building	2	13.38		18.3	489.71		
		Deduction windows	-72	1.8		1.5	-194.40		
			-72	0.6		0.9	-38.88		
		Deduction doors	-72	0.9		2.1	-136.08		
		Overhead water tank	2	4.3		3	25.80		
			2	10.10		3	60.60		
		top and bottom	2	4.30		10.1	86.86		
							1585.95		
		say					1600.00	1600.00	Sq.M
2	R2-CS-PL-09-c	Internal plaster							
		Hall	2	3.85	2.90		22.33		
			2	2.7	2.90		15.66		
		less door	-1	0.9	2.1		-1.89		
		less window	-1	0.6	0.9		-0.54		
		Balcony/Kitchen	2	2.37	2.9		13.75		
			2	2.35	2.9		13.63		
		less door	-1	0.9	2.1		-1.89		
		less window	-1	1.8	1.5		-2.70		
							58.35		
		for 36 rooms					2100.46	A	
		say 50% qty					1050.23	A'	
		Staircase passage Area							
		Main wall	4	7.45	18		536.40		
			4	2.4	18		172.80		
		wall top side	10	40	0.1		40.00		
		less opening	-24	0.9	2.1		-45.36		
							703.84	B	

		Say 50% qty					351.92	B'	
						Total A'+B'	1402.15		
		For painting				A + B	2804.30		
		say					2805.00	C	
						Say	1405.00	1405.00	Sq.M
3	R2-CS-PL-05	Ceiling plaster							
		Hall	1	3.8	2.75		10.45		
		Balcony/Kitchen	1	2.37	2.35		5.57		
		loft ceiling	1	1.2	1.3		1.56		
		Bath	1	1.2	1.8		2.16		
		WC	1	1	1.2		1.20		
							20.94		
		For 36 Rooms					753.82	A	
		say 50 % qty					376.91	A'	
		Passage							
		ceiling	2	2.4	7.45		35.76		
							35.76	B	
		say 50% qty					17.88	B'	
						Total A'+B'	394.79		
		for painting				A + B	789.58		
		say					800.00	C	
						say	400.00	400.00	Sq.M
4	R2-CS-PL-25	Extra for for all types of external plastering.							
		25% of Qty as item no R2-CS-PL-16-c				say	400.00	400.00	Sq.M
5	R2-CS-WP-39	Waterproofing to WC/Bath							
		Bath	30	1.2	1.8		64.80		
		W/C	30	0.9	1.2		32.40		
							97.20		
		say					100.00	100.00	Sq.M
6	R2-CS-WP-17	Terrace waterproofing							
		terrace area	1	35.31	13.38		472.45		
			-2	7.45	5.03		-74.95		
			-2	1.35	3.75		-10.13		

			-1	5.03	2.39		-12.02		
			-1	14.59	5.03		-73.39		
		water tank top	1	10.1	4.3		43.43		
		Balcony top	12	2	1.2		28.80		
							374.20		
						Say	400.00	400.00	Sq.M
7	R2-CS-WP-34	Providing water proofing treatment to existing RCC overhead tank,							
		OHWT							
		sides	2	10.10		3.00	60.60		
			2	4.30		3.00	25.80		
		bottom	1	10.10		4.30	43.43		
		Provisional qty for under ground water tank					40.00		
							169.83		
						say	170.00	170.00	Sq.m
8	R2-CS-WP-44	Water proofing treatment to the chajja							
		chajja	60	1.50	0.50		45.00		
						Say	45	45.00	Sq.m
9	R2-CS-CW-1-a	Providing and laying in position plain cement concrete Nominal Mix of 1:1.5:3 (1 cement OPC: 1.5 coarse sand : 3 graded stone aggregate 20 mm nominal size)							
		for plinth protection							
		front and back side	2	35.31	1.00	0.1	7.06		
		sides	2	15.38	1.00	0.1	3.08		
		duct	1	5.03	2.39	0.1	1.20		
			1	14.59	5.03	0.1	7.34		
			2	1.35	3.75	0.1	1.01		
							19.69		
						Say	20	20.00	Cu.m
10	R2-CS-CW-7-d	M-20 Concrete (coping) Lintels, beams, plinth beams, girders, floor beam, comping							
		Coping	1	97.38	0.35	0.1	3.41		
		Provisional qty for lintels					3.00		

							6.41		
						Say	7.00	7.00	Cu.m
11	R2-CS-CW-7-c	Slabs, provisional qty for slabs					5.00		
						Say	5	5.00	Cu.m
12	R2-CS-CW-7-b	Walls provisional qty for RCC pardis					5.00		
						say	5.00	5.00	Cu.m
13	R2-CS-CW-35-c	Reinforcement					1.50	1.50	MT
14	R2-CS-CW-45	Micro Concrete jacketing					4503.00	5000.00	Kg
15	R2-CS-CW-56	PMM 15 mm					985.00	985.00	Sqm
16	R2-CS-CW-55	Removing corrosion of steel					1285.00		
							1285.00	1285.00	Sqm
17	R2-CS-CW-57	PMM 30 mm					300.00	300.00	Sqm
	R2-CS-SS-07	Providing and fixing the Chemical Anchor Fasteners							
18	R2-CS-SS-07-a	M10 x 90 foil capsule (HVU) & M10 x 130 Rod					173.00	173.00	No
19	R2-CS-SS-07-b	M12 x 110 foil capsule (HVU) & M12 x 160 Rod					65.00	65.00	No
20	R2-CS-MW-4-b	Brick work Provisional qty for rooms and parapet walls					10.00		

						say	10.00	10.00	Cum
21	R2-CS-PN-4-a	Internal paint							
		Internal Plaster					2805.00		
		Ceiling Plaster					800.00		
							3605.00		
							3605.00	3605.00	Sq.M
22	R2-CS-PN-12-a	External paint							
		Quantity is same as per item No.- R2-CS-PL-16-c					1600.00		
							1700.00	1700.00	Sq.M
23	R2-CS-PN-4-b	Paint wood work							
		Doors	72	0.9	2.1		136.08		
		Windows	72	0.6	0.9		38.88		
							174.96		
						say	175.00	175.00	Sq.M
24	R2-CS-PN-4-c	Paint steel work					100.00		
							100.00	100.00	Sq.M
25	R2-CS-PN-15	Extra over paint							
		Assume 25% quantity of item No. CS-PN-12-a					400.00		
						say	400.00	400.00	Sq.m
26	R2-CS-FL-01-c	Kota flooring							
		Kota flooring							
		Passage	6	7.45	1.1		49.17		
		Landing	6	1.2	1.1		7.92		
							57.09		
		50 % qty					28.55		
						say	30.00	30.00	Sq.M
27	R2-CS-FL-07-c	Antiskid Flooring							
		WC	30	0.9	1.2		32.40		
		Bath	30	1.2	1.8		64.80		
							97.20		
						say	100.00	100.00	Sq.M
28	R2-CS-FL-31-a	Dado							

		Bath	2	1.2	1.8		4.32		
			2	1.9	1.8		6.84		
		less door	-1	0.75	1.8		-1.35		
		less louvers	-1	0.5	0.8		-0.40		
		WC	2	1	2.1		4.20		
			2	1.25	2.1		5.25		
		less door	-1	0.75	1.8		-1.35		
		less Louvers	-1	0.5	0.8		-0.40		
							17.11		
							34.22		
		For 30 Toilet /Bath					1026.60		
		Say				say	1030.00	1030.00	Sqm
29	R2-CS-FL-21-d	Treads							
		50% qty	50	1.1			55.00		
							55.00	55.00	Rmt
30	R2-CS-FL-38-d	Risers							
		50% qty	50	1.1			55.00		
							55.00	55.00	Rmt
31	R2-CS-FL-40-e	150mm marble frame							
		for the sides of doors of toilet and bathroom							
		Bath and wc	60	5.1			306		
							306	306	Rmt
32	R2-CS-FL-40-p	18mm thk. green marble for width upto 300 mm							
		Provisional					50		
							50	50	Rmt
33	R2-CS-FL-8-a	Vitrified flooring							
		provisional qty for rooms					100	100	Sqm
34	R2-CS-EW-1	Excavation							
		for plinth protection							
		front and back side	2	35.31	1.00	0.3	21.19		
		sides	2	15.38	1.00	0.3	9.23		
		duct	1	5.03	2.39	0.3	3.61		
			1	14.59	5.03	0.3	22.02		

			2	1.35	3.75	0.3	3.04		
							59.07		
						say	60.00	60.00	Cu.m
35	R2-CS-EW-26	Soling							
		for plinth protection							
		front and back side	2	35.31	1.00	0.23	16.24		
		sides	2	15.38	1.00	0.23	7.07		
		duct	1	5.03	2.39	0.23	2.76		
			1	14.59	5.03	0.23	16.88		
			2	1.35	3.75	0.23	2.33		
							45.29		
						say	50.00	50.00	Cu.m
36	R2-CS-DD-2	Demolishing R.C.C. slab,							
		Provisional qty					5.00		
						say	5.00	5.00	Cu.m
37	R2-CS-DD-3	Demolishing brick work							
		qty as per item no R2-CS-MW-4-b					10.00		
							10.00	10.00	Cu.m
38	R2-CS-DD-37-a	Dismantling C.I., UPVC 75 to 80 mm dia pipe.							
		Bath / kitchen pipe	12	18			216.00		
		extra for connectors	12	0.5			6.00		
		vent pipes	12	13			156.00		
							378.00		
						say	400.00	400.00	R.m
39	R2-CS-DD-37-b	Dismantling C.I., UPVC 100 mm dia pipe.							
		Rain water	12	18			216.00		
		WC pipe	12	21			252.00		
							468.00		
						say	500.00	500.00	R.m
40	R2-CS-DD-56	Removing any existing water proofing							
			60	1.5	0.5		45.00		
							50.00	50.00	Sq.m

41	R2-CS-DD-64	Removing flooring							
		Qty as per item No. R2-CS-FL-1-c						125.00	
		Qty as per item No. R2-CS-FL-7-c						90.00	
		Qty as per item No. R2-CS-FL-21-d (40 x 0.15)						6.00	
		Qty as per item No. R2-CS-FL-31-a						670.00	
		Qty as per item No. R2-CS-FL-38-d (40 x 0.25)						10.00	
		Qty as per item No. R2-CS-FL-40-e (204 x 0.15)						30.60	
		Qty as per item No. R2-CS-FL-40-p (50 x 0.30)						15.00	
		Qty as per item No. R2-CS-FL-8-a						100.00	
								1046.60	
								1050.00	1050.00 Rmt
42	R2-CS-DD-38-a	Dismantling GI pipes							
								500.00	500.00 Rmt
43	R2-CS-DD-65	Removing cement plaster							
		Qty as per item no R2-CS-PL-16-c						1700.00	
		Qty as per item no R2-CS-PL-9-c						1330.00	
		Qty as per item no R2-CS-PL-5						620.00	
								3650.00	
						say		3650.00	3650.00 Sq.M
44	R2-CS-DD-79	Removing soil pan						30.00	
								30.00	30.00 EA
45	R2-CS-DD-70	Removing and refixing existing door or window							
		Provisional						20.00	20.00 Nos
46	R2-CS-AT-2	Providing anti-termite treatment							
			1	97.38				97.38	
						say		100.00	100.00 Rm
		Provisional quantity per building (for wall etc)							
47	R2-CS-AW-04	aluminum louvered window	36	0.6	0.9			19.44	
						say		20.00	20.00 Sqm
48	R2-CS-SL-12-c	Providing and Fixing MS Safety grill							
		for louvers	36	0.6	0.9			19.4	

		provisional qty for windows	10	1.5	1.8		27.0		
							46.4		
						say	50.0	50.0	Sqm
49	R2-CS-PV-02	FRP doors							
		WC	30	0.75	1.8		40.50		
		Bath	30	0.75	1.8		40.50		
		Tercae Doors	1	0.8	1.8		1.44		
							82.44		
		Say					85.00	85.00	Sq.m
50	R2-CS-SS-32	Providing & fixing S.S. pipe hand rail							
			1	30			30.00		
							30.00	30.00	Mtr
51	R2-CS-PS-13-b	Providing and fixing white vitreous china water closet squatting pan (Indian type)	15				15.00	15.00	EA
52	R2-CS-PS-2-a	Providing and fixing white vitreous china pedestal type water closet (European type W.C. pan)	15				15.00	15.00	Ea
53	R2-CS-PS-87-a	(CPVC) pipes 15 mm nominal outer dia Pipes							
							150.00	150.00	Rmt
54	R2-CS-PS-87-b	(CPVC) pipes 20 mm nominal outer dia Pipes							
							100.00	100.00	Rmt
55	R2-CS-PS-87-c	(CPVC) pipes 25 mm nominal outer dia Pipes							
							100.00	100.00	Rmt
56	CS-PS-59-b-2	Providing and fixing trap of self cleansing design with screwed down or hinged grating with or without vent arm complete, including cost of cutting and making good the walls and floors : Sand Cast Iron S&S as per IS- 1729.					20.00	20.00	EA
57	R2-CS-PS-192	110 mm upvc pipes							

		qty as per item no R2-CS-DD-37-b					500.00	500.00	Rmt
58	R2-CS-PS-191	75mm upvc pipes							
		qty as per item no R2-CS-DD-37-a					400.00	400.00	Rmt
59	R2-CS-PS-163-b	SW Pipe 150 mm diameter							
			1	50			50.00	50.00	Rmt
60	R2-CS-PS-166-b-1	Gully trap							
			12				12.00	12.00	Each
61	R2-CS-PS-194	Constructing brick masonry inspection chamber							
			15				15.00	15.00	Rmt
62	R2-CS-PS-196	Providing & fixing M. S. angled ISA 5050 of 6 mm. welded frame							
			15				15.00	15.00	Each
63	R2-CS-PS-167-b	Dismantling of old S.W. pipes							
			1	50			50.00	50.00	Rmt
64	R2-CS-PS-90-a	Providing and fixing G.I. pipes 15 mm dia nominal bore		150			150.00	150.00	Mtr
65	R2-CS-PS-90-c	Providing and fixing GI pipes 25mm dia nominal bore		100			100.00	100.00	Mtr
66	R2-CS-PS-90-d	Providing and fixing GI pipes. 32mm dia nominal bore		150			150.00	150.00	Mtr
67	R2-CS-PS-90-f	Providing and fixing GI pipes 50mm dia nominal bore		100			100.00	100.00	Mtr
68	R2-CS-PS-93-a	Providing and fixing brass bib cock of approved quality :15 mm nominal bore		30			30.00	30.00	Each
69	R2-CS-SS-01	Structural steel							
		Provisional qty					1.00	1.00	MT

70	R2-CS-AW-01	two track aluminum window							
		Kitchen/ balcony windows	20	1.5	1.5		45.00		
						say	25.00	25.00	Sqm
71	R2-RW-3-17	Providing and fixing 60 mm thick lacquer							
		for plinth protection							
		front and back side	2	35.31	1.00		70.62		
		sides	2	15.38	1.00		30.76		
		duct	1	5.03	2.39		12.02		
			1	14.59	5.03		73.39		
			2	1.35	3.75		10.13		
							196.91		
						say	200.00	200.00	Sqm
72	R2-RW-3-14	Removing and refixing 60 mm thick pavers							
		provisional qty					200.00	200.00	Sqm
73	R2-CS-RM-95	FRP Chajja							
		provisional qty in chajja demolish					20.00		
							20.00	20.00	Sq.m
74	R2-CS-WW-05	Flush Doors							
		Provisional	20				20.00	20.00	Sqm
75	R2-CS-PN-14	Extra over item Paint							
		Qty as per item no R2-CS-PN-3 toR2-CS-PN-6					3880.00	3880.00	Sqm
76	R2-SWD-147	Supplying and fixing 0.90m x 0.45m internal size of rectangular C.I. air tight cover and frame							
			5				5.00	5.00	Each

Sd/-
S.E. (B.M.) F/S

Sd/-
A.E.(B.M.) City

Sd/-
E.E. (B.M.) City- II

Bill Of Quantities (Civil)

BOQ for 50 Tenaments & 72 Tenaments at Peru Chawl, Lalbaug in F/South Ward						
Sr No	ITEM CODE	ITEM DESCRIPTION	Qty	Unit	Rate	Amount
1	R2-CS-PL-16-c	Providing and applying 20 mm thick external sand faced cement plaster upto 10m from ground level and at all locations in cement mortar proportion specified below in two coats for masonry (except stone masonry) and concrete surfaces including providing water proofing compound to the first coat of plaster as per manufacturers specification, racking out joints, hacking of concrete surface, finishing, curing, scaffolding, etc complete as directed By Engineer In Charge. In cement mortar 1:3	3220	Sq.M	518	1667960
2	R2-CS-PL-09-c	Providing and applying 20 mm thick internal plaster with neeru finish at all heights and locations in cement mortar specified below in two coats for masonry(except stone masonry) and concrete surfaces including racking out joints, hacking of concrete surface, watering, finishing, curing, scaffolding etc complete as directed By Engineer In Charge. In cement mortar 1:4	2735	Sq.M	516	1411260
3	R2-CS-PL-05	Providing and applying 12mm thick internal plaster in cement mortar 1:3 with neeru finish at all heights and locations in one coat for masonry (except stone masonry) and concrete surfaces including racking out joints, hacking of concrete surface, watering, finishing, curing, scaffolding etc. complete.	1020	Sq.M	361	368220
4	R2-CS-PL-25	Extra for every additional height of 3m or part there of above 10m from ground level for all types of external plastering.	825	Sq.M	55	45375
5	R2-CS-WP-39	Providing the waterproofing treatment as per item no.CS-WP-38 but to the flooring of existing water closets, bathrooms, kitchen, nahanies, washing places, sanitary blocks etc. after removing existing flooring and brickbat coba etc. (The soil pan area will not be deducted. After completion of work leakage test shall be carried out after impounding the water for 7 days without any extra cost. The actual area treated including soil pan area will be measured and paid for).	170	Sq.M	1173	199410
6	R2-CS-WP-17	Providing and laying APP (Atactic Polypropylene Polymer) modified prefabricated five layer 3 mm thick water proofing membrane, black finished reinforced with non-woven polyester matt consisting of a coat of bitumen primer for bitumen membrane @ 0.40 litre/sqm by the same membrane manufacture of density at 25°C, 0.87-0.89 kg/ litre and viscosity 70-160 cps. Over the primer coat the layer of membrane shall be laid using Butane Torch and sealing all joints etc, and preparing the surface complete. The vital physical and chemical parameters of the membrane shall be as under : Joint strength in longitudinal and transverse direction at 23°C as 650/ 450N/5cm. Tear strength in longitudinal and transverse direction as 300/250N. Softening point of membrane not less than 150°C. Cold flexibility shall be upto -2°C when tested in accordance with ASTM, D - 5147. The laying of membrane shall be got done through the authorised applicator of the manufacturer of membrane 22.20.1 3 mm thick	870	Sq.M	486	422820
7	R2-CS-WP-34	Providing water proofing treatment to existing RCC overhead tank, basements, lift-pits and other underground structures. The treatment shall be done by giving INJECTIONS wherever necessary with waterproofing compound and cement solution as per tenderer's specifications into the floor & walls upto the	320	Sq.m	1343	429760

		full height of structures. All inherent holes, cavities, voids & honeycomb shall be filled up to make the structure consistent, homogenous resistant to water breakages, seepage, dampness and moisture etc. The floor shall then be treated with waterproofing metal coba of 30 mm to 35 mm thick in 1:4 C.S. mortar and walls with first coat of waterproofing plaster as per tenderer's specifications. Finally both floor and walls shall be finished smooth with jointless waterproofing plaster 1:3 C.S. 12 mm to 15 mm thick with water proofing materials as per tenderer's specifications in cement or finished rough to receive tile pavement or dado. The thickness of the treatment shall not be less than 50 mm to 60 mm for floors and 25 mm for walls. (The actual area of the treatment will be paid).				
8	R2-CS-WP-44	Water proofing treatment to the chajja after removing old plaster and roughening the surface and finishing the top surface with 20mm thk. 1:2 c.s. plaster with approved water proofing compounds and neat cement finish, the rate also includes for 1:3 c.s. facia of chajja to match the new surface(actual area treated will be paid).	95	Sq.m	327	31065
9	R2-CS-CW-1-a	Providing and laying in position plain cement concrete of specified grade with trap/granite/quartzite/gneiss metal mixing in concrete mixer including bailing out water, compacting, finishing surface, curing and including the cost of centering and shuttering at all level Nominal Mix of 1:1.5:3 (1 cement OPC: 1.5 coarse sand : 3 graded stone aggregate 20 mm nominal size)	30	Cu.m	7062	211860
10	R2-CS-CW-7-d	M-20 Concrete (coping) Lintels, beams, plinth beams, girders, floor beam, comping	14	Cu.m	9556	133784
11	R2-CS-CW-7-c	Slabs, Suspended floors, roofs, landings, balconies, canopy and access platform	10	Cu.m	11790	117900
12	R2-CS-CW-7-b	Walls (any thickness) including attached butteresses, retaining wall, shear wall, diaphragm wall , trench,pit walls, etc	15	Cu.m	10518	157770
13	R2-CS-CW-35-c	Providing and fixing in position steel bars reinforcement of various diameters for R.C.C. pile, pile caps, footings,raft,retaining wall,shear wall, lift wall, foundations, slabs, beams, columns, canopies, staircases, newels, chajjas, lintels, pardies, coping, fins, arches, etc. as per detailed designs, drawings and bar bending schedules,including straightening, cutting, bending, hooking the bars, binding with wires or tack welding, supporting as required etc. all complete at all levels.Thermo-Mechanically Treated steel bars. (Fe 500 D)	2.5	MT	76770	191925
14	R2-CS-CW-45	Providing Micro Concrete jacketing to walls of thickness upto 75 mm using Polymer modified cement premixed quartz sand aggregate packed in bags of standard manufacture, for high early strength of 40 N /mm sq.cm of approved brand. The dry product is to be mixed with 12.5% water by weight, along with washed and poured into rigid form work moulds & tamped properly, & cured for 3 days. [Payment is to be made by weight premixed of micro concrete product consumed as per site register records. No extra payment shall be made for shuttering or any other material.	6000	Kg	40	240000
15	R2-CS-CW-56	Providing and applying Ready mix Polymer modified cement mortar of average thickness 15mm using Polymer in one or more layers in proportion 1:5:15 of Polymer Cement Quartz Sand as manufacturer's specifications in specific layers, curing the surface after 72 hours of application with wet gunny bags etc and by finishing the surface with 12mm thick (1:3) Cement sand plaster.	1785	Sqm	2782	4965870
16	R2-CS-CW-55	Removing corrosion of steel reinforcement by mechanical means like wire brushing, chipping to remove loose rust and then applying rust removal solution by using brush application, leaving the surface for at least 15 to 30 minutes, then removing loose materials by scrubbing or with brush and applying polymer bond to the old concrete surface before applying Polymer mortar	2385	Sqm	33	78705

17	R2-CS-CW-57	Providing and applying Ready Mix Polymer modified cement mortar of average thickness 30mm using Polymer in two layers in proportion 1:5:15 of Polymer Cement Quartz Sand as manufacturer's specifications in specific layers, curing the surface after 72 hours of application with wet gunny bags etc and by finishing the surface with 12mm thick (1:3) Cement	600	Sqm	5281	3168600
	R2-CS-SS-07	Providing and fixing the Chemical Anchor Fasteners as specified below of Hilti Make or equivalent confirming to IS 1367 (Part 3) at required locations and level including drilling the hole, cleaning with blow pump and anchoring the bolt with chemical as per manufacturers specifications etc. complete as directed by Engineer In Charge.				
18	R2-CS-SS-07-a	M10 x 90 foil capsule (HVU) & M10 x 130 Rod	273	No	207	56511
19	R2-CS-SS-07-b	M12 x 110 foil capsule (HVU) & M12 x 160 Rod	80	No	320	25600
20	R2-CS-MW-4-b	Brick work with common burnt clay modular bricks of class designation 3.5 and above in superstructure above plinth level upto floor five level in all shapes and sizes in :Cement mortar 1:4 (1 cement : 4 coarse sand)	20	Cum	6930	138600
21	R2-CS-PN-4-a	Providing and applying first single coat of approved primer and two coats of synthetic enamel paint/flat oil paint of an approved make and colour as per manufacturers specifications to surfaces specified below, at all height and locations as directed including scaffolding, cleaning and preparing surfaces for painting by any approved means etc. complete as directed by Engineer-in-charge. For plastered wall surface	7500	Sq.M	153	1147500
22	R2-CS-PN-12-a	Providing and applying first single coat of approved primer and two coats of anti-algal, anti-fungal, exterior paint as specified below of an approved make and colour as per manufacturers specifications to any surface, upto 10m height from ground level and at all locations as directed including preparing surfaces for painting by any approved means, scaffolding, cleaning and curing etc. complete as directed by Engineer-in-charge. By using acrylic based exterior paint (External painting)	3320	Sq.M	177	587640
23	R2-CS-PN-4-b	Providing and applying first single coat of approved primer and two coats of synthetic enamel paint/flat oil paint of an approved make and colour as per manufacturers specifications to surfaces specified below, at all height and locations as directed including scaffolding, cleaning and preparing surfaces for painting by any approved means etc. complete as directed by Engineer-in-charge. For woodwork	335	Sq.M	140	46900
24	R2-CS-PN-4-c	Providing and applying first single coat of approved primer and two coats of acrylic distemper (oil bound distemper) of an approved make and colour as per manufacturers specifications to any surface, at all height and locations as directed including scaffolding, cleaning and preparing surfaces for painting with broom by any approved means, etc. complete as directed by Engineer-in-charge. Steel work	200	Sq.M	139	27800
25	R2-CS-PN-15	Extra over item no. CS-PN-7 to CS-PN-12 on exterior painting work of height more than 10 m from ground level for additional height of 3m or part thereof.	825	Sq.m	19	15675
26	R2-CS-FL-01-c	Providing and laying polished natural stone as specified below (Machine cut) of an approved quality and size for paving /flooring in plain and/or diamond /approved pattern including cement mortar bedding of 25 mm thick in 1:4 proportion, cement float, machine cutting, dressing, leveling, jointing, filling the joints with neat cement slurry or with required pigment, machine polishing at site, curing, finishing, etc complete as directed by Engineer In Charge. 25 to 30 mm thk. Shahbad stone of size 0.6m x 0.6m	155	Sq.M	1179	182745
27	R2-CS-FL-07-c	Providing and laying 8mm thk. ceramic tiles as specified below conforming to I.S.15622-2006 for flooring of an approved, quality, make, size and pattern/design, for flooring including	170	Sq.M	1701	289170

		cement mortar bedding of 25 mm thick in 1:4 proportion, neat cement float, cutting, leveling, jointing, filling the joints by neat cement slurry or approved colour grout, curing, finishing etc complete as directed by Engineer In Charge.				
28	R2-CS-FL-31-a	Providing and fixing 6mm thk. ceramic tiles as specified below conforming to I.S. 15622-2006 of approved quality, pattern and colour for dado in the wet area including preparing the surface and levelling in the desired line, backing of 20thk.cement mortar in porportion 1:3 with approved waterproofing compound, square cut top edge or chamfered top edge in cement mortar 1:3, cement float, machine cutting, leveling, jointing, filling the joints with neat cement slurry or approved colour grout, finishing, curing etc complete as directed by Engineer In Charge. Light coloured glazed ceramic tiles	1700	Sqm	1480	2516000
29	R2-CS-FL-21-d	Providing and fixing polished natural stone tiles/slab as specified below of approved quality, pattern and colour for flush /projected skirting and risers including preparing the surface and levelling in the desired line, backing of 20 thk.cement mortar in porportion 1:3, square cut top edge or chamfered top edge in cement mortar 1:3, cement float, machine cutting, leveling, jointing, filling the joints with neat cement or pigment mixed with cement, polishing, finishing, curing etc complete as directed by Engineer In Charge	95	Rmt	234	22230
30	R2-CS-FL-38-d	Providing and fixing polished natural stone slab as specified below of approved quality, pattern and colour for treads including preparing the surface and levelling in the desired line, in cement mortar 1:4, cement float, machine cutting, leveling, jointing, smooth cement plastering along the sides to match the existing surface in cement mortar 1:3, filling the joints with neat cement or pigment mixed with cement, polishing, finishing, curing etc complete as directed by Engineer In Charge. 15 to 20mm thk. Kota stone for width upto 300 mm	95	Rmt	664	63080
31	R2-CS-FL-40-e	Providing and fixing polished natural stone tiles as specified below of approved quality, pattern and colour for sill and jambs including preparing the surface and levelling in the desired line, cement mortar 1:3 bedding or backing, cement float, machine cutting, leveling, jointing, smooth cement plastering along the sides to match the existing surface in cement mortar 1:3, filling the joints with neat cement or pigment mixed with cement, finishing, curing etc complete as directed by Engineer In Charge. 18mm thk. green marble for width upto 150 mm	510	Rmt	304	155040
32	R2-CS-FL-40-p	18mm thk. green marble for width upto 300 mm	100	Rmt	476	47600
33	R2-CS-FL-8-a	Providing and laying 600 x 600 x 8 mm thk. vitrified tiles as specified below conforming to I.S.15622-2006 with water absorbtion less than 0.08% for flooring of an approved, quality, make and pattern /design for flooring including cement mortar bedding of 25 mm thick in 1:4 proportion, cutting, leveling, jointing, filling the joints by neat cement slurry or approved colour grout, curing, finishing etc complete as directed by Engineer In Charge.Light coloured glazed vitrified tiles	200	Sqm	1608	321600
34	R2-CS-EW-1	Excavation for foundations, substructures, basements, tanks, sumps, walls, chambers, manholes, trenches, poles, pits & general building works in all types of soils, vegetable earth, soft murum, running sand, shingle, turf clay, loam, peat, ash, shale, slag, chalk, garbage, muddy/ marshy/ slushy soil, marine clay, reclaimed land etc. for depths/lifts upto 1.5M measured from the ground level, including dressing/ trimming the sides, leveling and ramming of bottoms, manual dewatering, removing rank vegetation, backfilling in layers not more than 200mm thickness, watering, consolidating, compacting to achieve not less then 97% Modified Proctor density conforming to relevant IS, stacking the selected material in measurable heaps for future use within owners space or disposing within an initial lead of 150m as directed, loading, unloading, leveling excluding shoring, strutting etc. complete as directed by Engineer-in-Charge. Note: 1) The rate includes	90	Cu.m	307	27630

		the handling/supporting the existing utilities such as cables, drains, pipes, water mains etc. 2) It also includes the royalty and other taxes applicable if any. For more details refer General Notes.				
35	R2-CS-EW-26	Providing & Laying dry stone Rubble Soling with average 230 mm size hard stone set in regular lines, handpacked and interstices thoroughly filled with small chips including filling in with good quality murum brought from outside, compacting with iron rammers, watering, sand spreading 12mm thk. layer of grit on top etc complete as directed by Engineer In Charge. (Note: The rate includes the royalty and other taxes if any)	75	Cu.m	2231	167325
36	R2-CS-DD-2	Demolishing R.C.C. slab, R.C.C. wall of any thickness, R.C.C. beams, joists, R.C.C. columns, piles, pile caps etc., in any thickness and size manually/ by mechanical means including stacking of steel bars and disposal of unserviceable material within 50 metres lead as per direction of Engineer - in- charge.	10	Cu.m	1837	18370
37	R2-CS-DD-3	Demolishing brick work in lime or cement mortar including plaster, paint, etc. manually/ by mechanical means including stacking of serviceable material and disposal of unserviceable material within 50 metres lead as per direction of Engineer-in-charge.	30	Cu.m	484	14520
38	R2-CS-DD-37-a	Dismantling C.I., UPVC and asbestos vent pipes and shaft, soil, waste, rain water pipe, mild steel, GI and asbestos gutters, ridge and hips with fittings and clamps including stacking the material within 50 metres lead : 75 to 80 mm dia pipe.	600	R.m	43	25800
39	R2-CS-DD-37-b	Dismantling C.I., UPVC and asbestos vent pipes and shaft, soil, waste, rain water pipe, mild steel, GI and asbestos gutters, ridge and hips with fittings and clamps including stacking the material within 50 metres lead : 100 mm dia pipe.	800	R.m	44	35200
40	R2-CS-DD-56	Removing any existing water proofing layers of I. P. S. with bituminous joints and brick bat concrete over the existing terrace floor, chajja, top of headroom slab and canopy including cement vata and exposing R.C.C. slab top complete.	95	Sq.m	218	20710
41	R2-CS-DD-64	Removing mosaic, cement marble, granites non-slippery, tandur, kotah, shahabad stone or Indian Pattern stone, glazed tiles in flooring and dado including bedding brick bat coba etc., and delivering materials in Ward Office and carting away unserviceable materials.	2100	Rmt	240	504000
42	R2-CS-DD-38-a	Dismantling GI pipes	1000	Rmt	84	84000
43	R2-CS-DD-65	Removing cement plaster of any finish from the wall, complete with racking out the joints to a depth of 20 mm.	7300	Sq.M	147	1073100
44	R2-CS-DD-79	Removing soil pan, Urinal, wash basin and sink of any type, size make and brand including its bedding drainage fitting etc.	50	EA	110	5500
45	R2-CS-DD-70	Removing and refixing existing door or window with frames and shutters, making good the damaged brick work and applying 3 coats of Syn. Ena. paint.	40	Nos	1976	79040
46	R2-CS-AT-2	Providing anti-termite treatment around the periphery of the existing building conforming to IS-6313 (part III) by excavating trenches of 20cm width and exposing the sides of the columns, plinth beams and wall upto a depth of 300mm, rodding for the holes of 300mm deep and at 150m c/c in the trenches, treating with chloropyrifos EC 20 Emulsion or equivalent of 1% concentration by weight at the total rate of 2.25 Liters per meter including backfilling the trenches etc. complete as directed by Engineer-in-Charge covering 2 years guaranty.	200	Rm	66	13200

47	R2-CS-AW-04	Providing and fixing in position aluminum louvered window with anodised aluminum frame of approved make and of size 40mm x 20mm x 2.0mm (wt. 0.605 kg/Rm)	28	Sqm	4246	118888
48	R2-CS-SL-12-c	Providing and Fixing MS Safety grill of weight specified below for windows as per design including fabricating the grill using M.S. square / round bar, flats and angles including painting with one coat of red oxide zinc chromate primer and two coats of synthetic enamel paint of approved colour and brand etc complete as directed. Grill weighing 20 to 25 kg / sqm	100	Sqm	2828	282800
49	R2-CS-PV-02	Providing and fixing to frames 30 mm thick Fibre Glass Reinforced Plastic (FRP) panelled / extruded profiled door shutter of approved colour, brand and manufacture, made with fire - retardant grade unsaturated polyester resin, moulded to 3 mm thick FRP laminate for forming hollow rails and styles, with wooden frame and suitable blocks of seasoned wood inside at required places for fixing of fittings, cast monolithically with 5mm thick FRP laminate for panels conforming to IS: 14856 - 2000 etc complete as directed.	145	Sq.m	2382	345390
50	R2-CS-SS-32	Providing & fixing S.S. pipe hand rail along the wall in staircase or ramps or passages consisting of 50 mm dia. 18 gauge 304 grade stainless steel pipe. Supported with 25 mm 18 gauge S.S. pipe (304grade) brackets & 5mm thick tapered edge collar base plate fixed to wall with SS screws at approx. 600 mm center to center fixed horizontally or in inclined position at required height including grinding the welded joints, buffing,protecting the railing members by means of wrappers during construction etc. complete as per detailed drawing as directed by the Engineer in charge.	60	Mtr	1675	100500
51	R2-CS-PS-13-b	Providing and fixing white vitreous china water closet squatting pan (Indian type) Orissa pattern W.C. pan of size 580x440 mm	25	EA	2349	58725
52	R2-CS-PS-2-a	Providing and fixing white vitreous china pedestal type water closet (European type W.C. pan) with seat and lid, 10 litre low level white P.V.C. flushing cistern, including flush pipe, with manually controlled device (handle lever), conforming to IS : 7231, with all fittings and fixtures complete including cutting and making good the walls and floors wherever required :	25	Ea	6483	162075
53	R2-CS-PS-87-a	Providing and fixing Chlorinated Polyvinyl Chloride (CPVC) pipes,having thermal stability for hot & cold water supply including all CPVC plain & brass threaded fittings This includes jointing of pipes & fittings with one step CPVC solvent cement ,trenching ,refilling & testing of joints complete as per direction of Engineer in Charge. 15 mm nominal outer dia Pipes	300	Rmt	176.00	52800
54	R2-CS-PS-87-b	Providing and fixing Chlorinated Polyvinyl Chloride (CPVC) pipes,having thermal stability for hot & cold water supply including all CPVC plain & brass threaded fittings This includes jointing of pipes & fittings with one step CPVC solvent cement ,trenching ,refilling & testing of joints complete as per direction of Engineer in Charge.20 mm nominal outer dia Pipes	200	Rmt	219.00	43800
55	R2-CS-PS-87-c	Providing and fixing Chlorinated Polyvinyl Chloride (CPVC) pipes,having thermal stability for hot & cold water supply including all CPVC plain & brass threaded fittings This includes jointing of pipes & fittings with one step CPVC solvent cement ,trenching ,refilling & testing of joints complete as per direction of Engineer in Charge. 25 mm nominal outer dia Pipes	200	Rmt	245.00	49000

56	CS-PS-59-b-2	Providing and fixing trap of self cleansing design with screwed down or hinged grating with or without vent arm complete, including cost of cutting and making good the walls and floors : Sand Cast Iron S&S as per IS- 1729.	40	EA	1,179.00	47160
57	R2-CS-PS-192	Providing and fixing in position uPVC/SWR (Soil/Waste/Rain) pipe of type-B 110 mm dia. in any position including all fittings and accessories, making joints/connections water tight with solvent cement,scaffolding if necessary and making good the damages if any (excluding excavation and refilling the trenches) etc.complete as specified and directed. (All fittings and accessories like clamps, etc .should be of same brand. No separate payment shall be made for fittings and accessories).	800	Rmt	478	382400
58	R2-CS-PS-191	Providing and fixing in position uPVC/SWR pipe 75 mm dia. in any position including all fittings and accessories, making joints / connections water tight with solvent cement, scaffolding if necessary and making good the damages if any (excluding excavation and refilling the trenches) etc. complete as specified and directed.(No seperate payment shall be made for fittings and accessories).	600	Rmt	314	188400
59	R2-CS-PS-163-b	Providing, laying and jointing glazed stoneware pipes class SP-1 with stiff mixture of cement mortar in the proportion of 1:1 (1 cement : 1 fine sand) including testing of joints etc. complete :(stonewear pipe 150/200/250mm) 150 mm diameter	110	Rmt	460	50600
60	R2-CS-PS-166-b-1	Providing and fixing square-mouth S.W. gully trap class SP-1 complete with C.I. grating brick masonry chamber with water tight C.I. cover with frame of 300 x300 mm size (inside) the weight of cover to be not less than 4.50 kg and frame to be not less than 2.70 kg as per standard design : With common burnt clay F.P.S. (non modular) bricks of class designation 3.5	22	Each	2913	64086
61	R2-CS-PS-194	Constructing brick masonry inspection chamber 90cm x 45cm x30cm in cement mortar 1:4 (1 cement : 4 coarse sand) with R.C.C. top slab with 1:2:4 mix (1 cement : 2 coarse sand : 4 graded stone aggregate 20 mm nominal size), foundation concrete 1:4:8 mix (1 cement : 4 coarse sand : 8 graded stone aggregate 40 mm nominal size), inside plastering 12 mm thick with cement mortar 1:3 (1 cement : 3 coarse sand) finished with floating coat of neat cement and making haunches, channels in cement concrete 1:2:4 (1 cement : 2 coarse sand : 4 graded stone aggregate 20 mm nominal size) finished with a floating coat of neat cement complete as per standard design.	30	Rmt	3629	108870
62	R2-CS-PS-196	Providing & fixing M. S. angled ISA 5050 of 6 mm. welded frame for rectangular inspection chamber of 90 cm x 45 cm. with, 1 : 2 : 4 R. C. C. cover of approved design, 50mm. thick fixed complete including cement sand filleting 1 : 1 in C. S. complete as directed (Including fixing in cement mortar with cement and sand filleting around C. I. Frame and removal of the existing frame and cover if any. The frame and cover must be weighed before fixing in position.) (The dimension specified are clear inside dimensions of the frames. In case of M. S. angled frame, the proper hold fasts &fastening should be embedded in c.c.)	25	Each	1855	46375
63	R2-CS-PS-167-b	Dismantling of old S.W. pipes including breaking of joints and bed concrete stacking of useful materials near the site within 50 m lead and disposal of unserviceable materials into municipal dumps : 150mm dia.	110	Rmt	56	6160
64	R2-CS-PS-90-a	Providing and fixing G.I. pipes complete with G.I. fittings including trenching and refilling etc. 15 mm dia nominal bore	300	Mtr	199	59700
65	R2-CS-PS-90-c	Providing and fixing GI pipes complete with GI fittings including treaching and refilling etc. 25mm dia nominal bore	200	Mtr	281	56200

66	R2-CS-PS-90-d	Providing and fixing GI pipes complete with GI fittings including treaching and refilling etc. 32mm dia nominal bore	300	Mtr	331	99300
67	R2-CS-PS-90-f	Providing and fixing GI pipes complete with GI fittings including treaching and refilling etc. 50mm dia nominal bore	200	Mtr	470	94000
68	R2-CS-PS-93-a	Providing and fixing brass bib cock of approved quality :15 mm nominal bore	55	Each	313	17215
69	R2-CS-SS-01	Providing, detailing, fabricating and fixing at desired location using hot rolled sections and MS Plates of grade Fe 250 as per specifications and approved fabrication drawings (which are to be prepared by Contractor and got approved from Engineer), transporting to site and erecting structural steel members for all heights & at all levels including provision of necessary erection bolts, fixing bolts, nuts, washers, cleats, stiffeners, gussets, base plate, and all necessary fixtures and operations like preheating as per specifications, straightening, bending, cutting, drilling, grinding, machining if specified, welding, grinding and removing the welding burr and preparing surface for painting with wire brush cleaning and applying two coats of epoxy red oxide zinc phosphate primer of 30 microns each and two coats of Epoxy Corrosion Resistant Enamel paint of 30 microns after fabrication including touching up with spray painting after erection etc complete as directed by Engineer In Charge. (The qty. for this item shall be measured for gusset plates, base plates, bolts in M.T.)	2	MT	80088	160176
70	R2-CS-AW-01	Providing and fixing in position two track aluminum window of extruded modular and anodized aluminum sections of approved make and of size 61.85 mm x 45.5 mm x 1.3 mm thk (wt 1.055 kg/Rm) for bottom, 61.85 mm x 31.75 mm x 1.3 mm thk. (wt 0.659 kg/Rm) for top & sides, mounted on anodized aluminum rectangular frame of size 63mm x 38mm x 2.0mm(1.054). The shutter comprising of bearing bottom and top of size 40mm x 18 mm x 1.25 mm thk (wt. 0.417 Kg/Rm) Interlocking section of size 40mm x 26,7 mm x 1.10 mm thk. (Wt. 0469 kg./Rm) and hand sides of 40mm x 18mm x 1.25 mm thk (wt. 0.417kg/Rm) with 5 mm thick plain / frosted / tinted glass fixed in shutter including approved quality neoprene gasket, fixtures, fastenings and accessories like PVC rollers, PVC weep holes, locks, handles etc. complete as directed by Engineer In Charge. (Note: anodic film must not be less than 15 microns i.e. AC-15 as per IS, the anodizing must be scaleted by keeping the anodized section in boiling de-anodized water for a period of one hour)	50	Sqm	5266	263300
71	R2-RW-3-17	Providing & fixing in the footpath, 60 mm thick Lacquer coated (Reflective) interlocking gray cement concrete pavers in red (Terra Cotta) Black, Brown, Lemon Yellow or any colour with vermeticular or any antiskid texture on top surface of approved pattern/ shape and colour having average crusting strength 40 N/mm ² manufactured in double layer precast concrete blocks. The top layer of paver block should be 12 to 15 mm thick and consist cubical shape stone aggregate 8 mm size sieve 100% passing and retain on 4.75 mm size sieve , silica sand and with pure iron oxide ultra voilette stabilized pigment @ 5% by weight of cement and should be coated with lacquer having hard, high abrasive resistance and water repellent. The bottom layer should be 45 to 48 mm thick having 12 mm size sieve 100% passing aggregate as per technical specification placed on uniformly graded river sand cushioning of average compacted thickness 25 mm properly compacted with mechanical compactor with required level, grade and camber etc. complete as specified and as directed by the Engineer.	300	Sqm	858	257400
72	R2-RW-3-14	Removing & refixing interlocking concrete pavers of 60mm thick, of any size, shape and colour considering 10% breakage	400	Sqm	215	86000

		area of paver block while removing same from position and replacing the same by new paver blocks having average crushing strength of not less than 40N/mm ² as per technical specification sand IS Code 15658:2006, placed on average compacted thickness of 25 mm well graded sand cushioning uniformly compacted with proper capacity mechanical compactor with required level, grade and camber etc. complete as specified and as directed by the Engineer.				
73	R2-CS-RM-95	Providing & fixing factory made Fibreglass Reinforced plastics (F.R.P.) chajja 4 mm thick of required colour, size and design made by Resin Transfer Moulding (RTM) Machine Technology, resulting in void free compact laminate in single piece, having smooth gradual slope curvature for easy drainage of water and duly reinforced by 2 nos vertically and 1 nos horizontally 50x2 mm thick M.S. flat with 12 mm in built hole for grouting on the existing wall along with the 50 mm flanges duly inserted and sealed in the wall complete in one single piece casted monolithically, including all necessary fittings. The FRP chajja should be manufactured using unsaturated Polyester resin as per IS:6746, duly reinforced with fibre glass chopped strand mat (CSM) as per IS:11551 complete with protective gel coat U/V coating on top for complete resistance from the extreme of temperature, weather and sunlight.	40	Sq.m	2328	93120
74	R2-CS-WW-05	Providing and fixing superior quality factory made single or double leaf Phenol Bonded solid core flush door shutters commercial type hot pressed conforming to IS:2202 (Part I,II) 1991 including 12 mm thk teak wood lipping all around with one coat of primer, putty and 2 coats of synthetic enamel paint on both faces etc. complete as directed. (Hinges, aldrops & standard door hardware to be paid separately) 25mm thick shutter	40	Sqm	1436	57440
75	R2-CS-PN-14	Extra over item no. CS-PN-3 to CS-PN-6 for preparing and finishing plastered wall surfaces / concrete surfaces, steel or wood surfaces in line and level for acrylic (oil bound) distemper/ synthetic enamel paint or plastic emulsion paint by scrapping/removing the old paint if any with wire brush or blades and rubbing, with sand papers as required, filling in cracks in cement mortar 1:3, applying the whole surface with mixture of whiting powder or plaster of paris and double boiled linseed oil of premium quality or second quality synthetic enamel paint, filling the cracks with premium quality putty or hard glue in case of woodwork, rubbing down and even up the surface by any approved means etc. complete as directed by Engineer-in-charge.	7775	Sqm	15	116625
76	R2-SWD-147	Supplying and fixing 0.90m x 0.45m internal size of rectangular C.I. air tight cover and frame	10	Each	28889	288890
77	R2-CS-RW-08	Providing and fixing in position UV resistant, fire retardant, virtually unbreakable and temperature resistant (-40° C to +130° C) Polycarbonate corrugated sheet of 2mm thickness for roof of approved make to match the roof profile at any height with G.I. J hooks bolts of G.I. clamps nuts & bolts or with self drilling fastener and EPDM washer etc. complete as directed.	180	Sqm	1473	265140
					Total	25576905

Sd/-
S.E. (B.M.) F/S

Sd/-
A.E.(B.M.) City

Sd/-
E.E. (B.M.) City- II

Measurement Sheet (Electrical)

Measurement Sheet 50 & 72 tenaments									
Discription	TL	FAN	Bell	Exhaust Fan	CFL	Total Point	HP	IP	PP
Hall	1	1	1		1	4	2	3	1
Kitchen	1	1		1	1	4	2	2	1
Bathroom & WC					2	2			1
TOTAL	2	2	1	1	4	10	4	5	3
Similar 100 rooms	200	200	100	100	400	1000	400	500	300

50 & 72 tenaments	50	72	total
Compound light	8	10	18
passage & staircase TL	40	48	88
meter room	1	1	2
pump room	1	1	2
		Total TL	92
	total light point	1010	

sd/-	sd/-
S.E.(M&E) BM	A.E.(M&E) BM

Bill of Quantities(Electrical)

MUNICIPAL CORPORATION OF GREATER MUMBAI						
Subject:- Electrical Estimate of Major Structural Repairs of 50 & 72 Municipal Tenements, Peru chawl at Gas Company Lane , Lalbaug , Mumbai in F/South ward.						
<u>Schedule of quantities and rates.</u>						
<u>AE/M&E/ 16 / ChE(BM) of 2022 – 2023.</u>						
PART - A						
Sr. No	FME 2018 item No.	Description	Qty.	Rate Rs.Ps.	Per	Amount Rs.Ps
		<u>Meter leads:-</u>				
1	R2-ME-1-10-c	1.1 kV grade 2 nos. (P+N) copper conductor flexible cable of area 4.0 sq mm and 1no. (E) 2.5 sq. mm copper cable for 30 /32 Amp. single phase switch.	250	458.00	Mtr.	114500.00
2	R2-ME-1-10-e	3(PH) Noss. single core Cu PVC insulated flexible cable of 25 Sq.mm. for phases & 1 single core Cu PVC insulated flexible cable for neutral of 10 Sq.mm. for 63 Amp TPNSS switch.	20	1468.00	Mtr.	29360.00
		MCBs in 16SWG sheet steel metal box				
3	R2-ME-1-19-f	40A to 63A DP MCB (At meter room for Qrtrs & common meter)	122	3581.00	Each	436882.00
4	R2-ME-1-19-c	63 Amp. TPN MCB	2	5143.00	Each	10286.00
5	R2-ME-1-7-h	30Amp.DP switch (i.e. 'TICINO' type) with neon indicator, fuse links & complete with necessary fixing arrangement. (Switch shall be of ISI mark only).	50	179.00	Each	8950.00
6	R2-ME-1-27-a	415V Pump panel with 63A MCCB as incomer with phase indicator and ammeter & voltmeter with selector switches, 2Noss. Of 25A MPCB with DOL Starter, local push button station & contactor of required rating as outgoing	2	98304.00	Nos	196608.00
		<u>Switchgear at distribution position.</u>				
7	R2-ME-1-13-d	IP 42 Wall/column Mounted distribution board with one no of DP 32A MCB as incomer and 6 nos 10A SP MCB as outgoing (12 way SPN DB) (For common light passage & compound)	4	5533.00	Each	22132.00

8	R2-ME-1-13-c	IP 42 Wall/column Mounted distribution board with one Nos of DP 16/32A MCB as incomer and 4 Noss 6A/10A SP MCB as outgoing (8 way SPN DB	122	4449.00	Each	542778.00
		<u>EARTH LEAKAGE CIRCUIT BREAKER / RESIDUAL CURRENT CIRCUIT BREAKER:(With 100 mA SENSITIVITY & COMPLETE WITH & INTERCONNECTION & WIRING:</u>				
9	R2-ME-1-25-c	40Amp. 2Pole ELCB	248	5079.00	Each	1259592.00
10	R2-ME-1-25-g	63Amp. 4Pole	2	6707.00	Each	13414.00
		<u>1.1 kV grade stranded Al conductor, XLPE insulated, extruded PVC inner and outer sheathed, galvanised steel round or strip armoured cables</u>				
11	R2-ME-2-1-b	2C x 4.0 Sq.mm (for passage)	2000	76.00	Mtr.	152000.00
12	R2-ME-2-1-c	2C x 6.0 Sq.mm (for meter cabin to house DB)	3500	89.00	Mtr.	311500.00
13	R2-ME-2-1-s	4C x 16 Sq.mm for Pumps	200	194.00	Mtr.	38800.00
		<u>CABLE END TERMINATION</u>				
14	R2-ME-2-11-b	2C x 6 Sq.mm	244	159.00	Set	38796.00
15	R2-ME-2-11-a	2C x 2.5/4 Sq.mm	200	104.00	Set	20800.00
16	R2-ME-2-11-r	4C x 16 Sq.mm	14	305.00	Set	4270.00
		Point wiring by using FRLSH insulated copper cconductors (alongwith same size of FRLSH insulated copper conductor for earthing & 3 plate ceiling rose) using CASING-N CAPING				
17	R2-ME-3-48-a	Light /Fan / Ex. fan Points	1010	751.00	Pt.	758510.00
18	R2-ME-3-48-b	2/3 Pin Independent Plug (IP)	500	870.00	Pt.	435000.00
19	R2-ME-3-48-d	Bell Point with Bell / Buzzer & 1 Bell Push	100	944.00	Pt.	94400.00
20	R2-ME-3-48-c	5A/6A - 3/5 Pin Plug On Board	400	305.00	Pt	122000.00
21	R2-ME-3-34-i	15 / 5 A / 6 A Combined Power Plug Socket Point with Fuse and Indicating Lamp, One 15 Amp SP Switch	300	1216.00	Pt	364800.00
22	R2-ME-3-17-b	2 X 2.5 sq. mm + 1 X 2.5 sq. mm earth wire in 20 x 12 mm (1/2")	3500	170.00	Mtr	595000.00
		<u>FITTINGS & FIXTURES:</u>				
23	R2-ME-4-34-a	1X 18W (LED Tube light) 24-36 W	92	538.00	Nos	49496.00
24	R2-ME-4-27-d	SITC of LED Street Light fittings:- 48-60 W	18	5332.00	Nos	95976.00

25	R2-ME-10-3-e	Swan neck type bracket for fixing HPMV / HPSV lamp fixtures mounting on wall / shed etc. 0.5 to 1.2 Mtrs.	18	798.00	Nos	14364.00
26	R2-ME-4-15-a	S' type M.S. fan hook fabricated from suitable dia. M.S.rod duly painted for fixing of ceiling fan. The 'S' type hook shall be fixed to steel bar in RCC ceiling. The ceiling shall be replastered with sand, cement & neeru etc. The cost of labours for chipping out ceiling upto steel bar & fixing of 'S' hook & resurfacing the ceiling is included in the cost of item.	200	306.00	Each	61200.00
27	R2-ME-4-12-t	Supply and fixing of Step type Electronic Fan Regulator minimum rated for 100W	200	448.00	Each	89600.00
		<u>16 SWG G.I.Junction Boxes Complete With Earthing Terminal, Interconnection & Wiring</u>				
28	R2-ME-1-20-b	100mm x 100mm x 50mm size GI Junction box with knock out & 10Amp. Connector block /strip	92	131.00	Each	12052.00
29	R2-ME-1-21-a	SMCJB - 1414, Hinged cover, Size 170 x 170 x 105mm	18	1253.00	Each	22554.00
		<u>Angle iron</u>				
30	R2-ME-1-31-a	25 x 25 x 3 mm of M.S.angle.	100	150.00	Mtr.	15000.00
		<u>WOODEN ITEMS</u>				
31	R2-ME-1-30-a	Supply and fixing 12 mm thick Marine Ply Plank	80	1641.00	Sq.Mtr.	131280.00
32	R2-ME-1-30-b	Supply and fixing 20 mm thick Marine Ply Plank	30	1807.00	Sq.Mtr.	54210.00
33	R2-ME-1-30-c	Supply and fixing T. W.batten 25 mm x 40 mm.	30	78.00	Mtr.	2340.00
34	R2-ME-1-30-f	Marine Ply service cupboard made from 20 mm. thick Marine Ply. planks and 150 mm/200 mm. wide planks (panels) fixed on Marine Ply frame 25 x 40 mm. size (Marine Ply batten) and by using heavy duty hinges of stainless steel and locking arrangement for front doors danger board etc. Entire Marine Ply cupboard shall be dully varnished as per approved manner.	10	23784.00	Cu. Mtr	237840.00
		<u>REMOVAL</u>				
35	R2-ME-8-1-a	Removal of point wiring (Light ,fan points,IP,PP,call bell,gong bell,bell indicator points)	2310	9.00	Each	20790.00
36	R2-ME-8-1-g	Removal of fixtures / fittings / ceiling fans / bulkhead / street light / gyeser etc.	310	40.00	Each	12400.00

37	R2-ME-8-1-h	Removal of cable from 1.5 sq.mm to 3-1/2 core x 35 sq.mm.	9200	9.00	Mtr.	82800.00
38	R2-ME-8-1-b	Removal of switchgears / ELCB / RCCB upto 32 Amp / 40 Amp	302	11.00	Nos	3322.00
39	R2-ME-8-1-m	Removal of fan regulator. (All types)	200	8.00	Nos	1600.00
40	R2-ME-8-1-u	Removal of all types and capacities of pump sets (Monoblock / Coupled / Jet type) with all accessories such as valves etc. with demolishing cement concrete foundation.	4	138.00	Nos	552.00
		<u>Earthing (SP-ME-TS-37)</u>				
41	R2-ME-7-1-c	Earthing station with 600 mm x 600 mm x 6 mm galvanised iron plate & 50 mm dia. G.I. pipe, 3000mm long GI pipe (Class B or better) earth pit as per IS 3043. The earth pit shall be provided with watering pipe (Class B) with wire meshed funnel, 25x3 GI strip / 8 SWG GI wire up to chamber (wire or strip size as per fault level), disconnecting links with 600 x 600 mm (clear) RCC chamber & heavy duty 3mm thick CI chequered plate cover with hinge & stainless steel bolts. Bentonite/ Charcol & Salt shall be provided for earth pits. Excavation, backfilling, removal of excess soil is included in the scope	6	17789.00	Each	106734.00
42	R2-ME-7-4-e	25 x 3mm G	100	49.00	Mtr.	4900.00
43	R2-ME-7-4-l	Bare G.I. conductor size 10 SWG.	5700	6.00	Mtr.	34200.00
		<u>PUMPS</u>				
44	R2-ME-6-4-w	Monoblock pumpsets: 7.5 H. P. three phase motor, with head of (26-42 mtr.) giving discharge of (11.75 – 2.5 lps) (60 x 50mm). Pump body: Cast Iron, Impeller: Cast Iron, Shaft SS410	2	48683.00	Nos	97366.00
45	R2-ME-6-4-n	Monoblock pumpsets: 5 H. P. three phase motor, with head of (16-32 mtr.) giving discharge of (12 – 5 lps) (65 x 50mm). Pump body: Cast Iron, Impeller: Cast Iron, Shaft SS410	2	37578.00	Nos	75156.00
46	R2-ME-6-7-g	65 mm dia. C Class GI Pipe	60	960.00	Mtr	57600.00
47	R2-ME-6-7-f	50 mm dia. C Class GI Pipe	80	762.00	Mtr	60960.00
48	R2-ME-6-9-f	50 mm dia. NRV	4	12649.00	Nos	50596.00
49	R2-ME-6-11-a	15 mm dia Gate Valve	4	3623.00	Nos	14492.00
50	R2-ME-6-11-f	50 mm dia Gate Valve	4	13212.00	Nos	52848.00
51	R2-ME-6-8-g	65 mm dia.. FOOT VALVE	4	3858.00	Nos	15432.00
52	R2-ME-6-16-a	Supply & fixing Pressure Guage Range 0-10 Kg/Sq.cm	4	601.00	Nos	2404.00
53	R2-ME-6-6-b	Cement concrete foundation using M-20 cement concrete mix with J shaped foundation bolts where required.	8	8279.00	Cum	66232.00

REFIXING:						
54	R2-ME-8-2-c	Refixing of tubelight fixture with new flexible wire accessories & using old conduit pipe or old T. W. Round block.	10	63.00	Each	630.00
55	R2-ME-8-2-d	Refixing of ceiling fans.	200	50.00	Each	10000.00
56	R2-ME-8-2-h	Refixing of 2 core/ 3 core/ 3-1/2 core / 4 core/ 6 core copper /aluminium conductor armoured / unarmoured cable 1.5 sq.mm. to 16 sq.mm. size on wall / ceiling etc.	9200	52.00	Mtr	478400.00
57	R2-ME-8-2-q	Refixing of telephone wires/ cables, any type of communication /data cables/ wires in PVC conduit/casing n caping /concealed etc	2000	52.00	Mtr	104000.00
TOTAL of PART ' A ' -						7709704.00
NOTE :		1. First category material (for cables,point wiring and fixtures) shall be used as per approved list of material FME-2018.				
		2. The removed material in working condition such as ceiling fans,Tube lights shall be handed over to the Tenant for refixing at the time of electrification work. Rebate should be considered accordingly.				
		3. The work shall be carried out as per specifications of USOR-2018				
sd/-			sd/-			
S.E.(M&E) BM			A.E.(M&E) BM			

PART ' B ' (REBATE)

Subject:- Electrical Estimate of Major Structural Repairs of 50 & 72 Municipal Tenements, Peru chawl at Gas Company Lane , Lalbaug , Mumbai in F/South ward.

Note :- 1) Rebate charges for removed old switchgears fittings, fixtures, accessories, cables etc. shall be paid as per actuals at site.

2. The removed material in working condition such as ceiling fan shall be handed over to the building incharge for refixing the same at the time of electrification work. Rebate should be considered accordingly.

S r N o	FM E 201 8 ite m No.	Description	Qty.		Rate Rs.Ps	Per	Amount Rs. Ps.
	-	<u>Rebate for taking away removed old material:</u>	-	-			
5 8	R2- ME -8- 4-a	Point wiring in Aluminium conductor.	231 0	Pts	-10.00	Eac h	- 23100.0 0
5 9	R2- ME -8- 7-a	Aluminium cable upto 3-1/2 C x 35 sq. mm (Including 3-1/2 core x 35 sq.mm.)	920 0	Mtr	-14.00	Mtr.	- 128800. 00
6 0	R2- ME -8- 5-a	Switchgears upto 100 Amps (including 100 Amp.)	250	No s.	-47.00	Eac h	- 11750.0 0
6 1	R2- ME -8- 8-a	All types of tube light fittings / fixtures with down suspension rods ball socket and flanges.	92	No s.	-37.00	Eac h	- 3404.00
6 2	R2- ME -8- 9-a	Rebate for Monoblock / coupled pumpset upto 5 HP.	2	Set	- 1000. 00	Set	- 2000.00
6 3	R2- ME -8- 9-b	Rebate for Monoblock / coupled pumpset above 5 HP to 10 HP.	2	Set	- 1489. 00	Set	- 2978.00
6 4	R2- ME -8- 9-e	Rebate for B' & 'C' G.I. pipe with accessories all sizes.	140	Mtr	-14.00	Mtr	- 1960.00
6 5	R2- ME -8- 10- b	Rebate for Brass/ gun metal valve: foot valves 65mm dia. to 100 mm dia.	4	No s	-69.00	Nos	-276.00

6 6	R2- ME -8- 11- b	Rebate for Brass / gun metal valves: non return valves: 65 mm dia. to 100 mm dia.	4	No s	- 140.0 0	Nos	-560.00
6 7	R2- ME -8- 12- a	Rebate for brass / gun metal valves: gate valves:12 mm dia. to 50 mm dia.	4	No s	-30.00	Nos	-120.00
TOTAL of PART ' B ' - II							- 174948. 00
sd/-							
S.E.(M&E) BM				sd/-			
S.E.(M&E) BM				A.E.(M&E) BM			

MUNICIPAL CORPORATION OF GREATER MUMBAI

AE/M&E/ 16 / ChE(BM) of 2022 – 2023.

Subject:- Electrical Estimate of Major Structural Repairs of 50 & 72 Municipal Tenements, Peru chawl at Gas Company Lane , Lalbaug , Mumbai in F/South ward.

SUMMARY SHEET

Sr. No.	Description of work	Amount Rs. Ps.
1)	Total of PART ' A ' - Rs.	7709704.00
	Less Rebate:- Total of PART ' B ' Rs.	-174948.00
	Total of PART ' A ' - 'B' - Rs.	7534756.00
	Add 4% Physical Contingencies Rs.	301390.24
	Sub Total =	7836146.24
	Add 10% Supervision charges Rs.	783614.62
	Sub Total =	8619760.86
2)	Lumpsum provision for:	
i)	Supply company's charges for shifting of service cable & connecting meters & earthwire pipe etc.	100000.00
ii)	Reinstatement of cable trenches.	
	Total: Rs.	8719760.86
	Say Rs.	8719770.00

(Say Rs. Eighty Seven Lakh Nineteen Thousand Seven Hundred Seventy only)

sd/-

S.E.(M&E) BM

sd/-

A.E.(M&E) BM

SECTION 9
GENERAL CONDITIONS OF CONTRACT

General Conditions of Contract

A. General

1. Definitions

- 1.1 Terms which are defined in the Contract Data are not also defined in the Conditions of Contract but keep their defined meanings. Capital initials are used to identify defined terms.

The “Contract” shall mean the tender and acceptance thereof and the formal agreement if any, executed between the Contractor, Commissioner and the Corporation together with the documents referred to therein including these conditions and appendices and any special conditions, the specifications, designs, drawings, price schedules, bills of quantities and schedule of rates. All these documents taken together shall be deemed to form one Contract and shall be complementary to one another.

The Contract Data defines the documents and other information which comprise the Contract.

The “Contractor” shall mean the individual or firm or company whether incorporated or not, whose tender has been accepted by the employer and the legal successor of the individual or firm or company, but not (except with the consent of the Employer) any assignee of such person.

The Bidder is a person or corporate body who has desired to submit Bid to carry out the Works, including routine maintenance till the tender process is concluded.

The Contractor's Bid is the completed bidding document submitted by the Contractor to the Employer.

The “Contract Sum” means the sum named in the letter of acceptance including Physical contingencies subject to such addition thereto or deduction there-from as may be made under the provisions hereinafter contained.

Note : The contract sum shall include the following –

- In the case of percentage rate contracts the estimated value of works as mentioned in the tender adjusted by the Contractor's percentage.
- In the case of item rate contracts, the cost of the work arrived at after finalisation of the quantities shown in schedule of items / quantities by the item rates quoted by the tenderers for various items and summation of the extended cost of each item.
- In case of lump sum contract, the sum for which tender is accepted.
- Special discount / rebate / trade discount offered by the tenderer if any and accepted by the Corporation.
- Additions or deletions that are accepted after opening of the tenders.

The "Contract Cost" means the Contract Sum plus Price Variation. This cost shall be included in the letter of acceptance.

A Defect is any part of the Works not completed in accordance with the Contract.

The Defects Liability Certificate is the certificate issued by the Engineer, after the Defect Liability Period has ended and upon correction of Defects by the Contractor.

Drawings means all the drawings, calculations and technical information of a like nature provided by the Engineer to the Contractor under the Contract and all drawings, calculations, samples, patterns, models, operation & maintenance manual and other technical information of like nature submitted by the Contractor and approved by the Engineer.

The Authority shall mean Municipal Corporation of Greater Mumbai (MCGM)

The "Employer" shall mean the Municipal Corporation for Greater Mumbai / Municipal Commissioner for Greater Mumbai, for the time being holding the said office and also his successors and shall also include all "Additional Municipal Commissioners, Director (Engineering Services & Projects)" and the Deputy Municipal Commissioner, to whom the powers of Municipal Commissioner, have been deputed under Section 56 and 56B of the Mumbai Municipal Corporation Act.

The Engineer in-charge shall mean the Executive Engineer in executive charge of the works and shall include the superior officers of the Engineering department i.e. Dy.Ch.E/Ch.Eng. and shall mean and include all the successors in MCGM

The Engineer's Representative shall mean the Assistant Engineer, Sub. Engineer/Jr. Engineer in direct charge of the works and shall include Sub Eng./ Jr. Eng of Civil section/ Mechanical section/ Electrical section appointed by MCGM.

The "Engineer" shall mean the City Engineer / the Hydraulic Engineer / the Chief Engineer / the Special Engineer, appointed for the time being or any other officer or officers of the Municipal Corporation who may be authorized by the commissioner to carry out the functions of the City Engineer / the Hydraulic Engineer / the Chief Engineer / the Special Engineer or any other competent person appointed by the employer and notified in writing to the Contractor to act in replacement of the Engineer from time to time.

Contractor's Equipment means all appliances and things of whatsoever nature required for the execution and completions of the Works and the remedying of any defects therein, but does not include plant material or other things intended to form or forming part of the Permanent Works.

The Initial Contract Price is the Contract Price listed in the Employer's Letter of Acceptance.

The Intended Completion Date is the date on which it is intended that the Contractor shall complete the construction works. The Intended Completion Date is specified in the Contract Data. The Intended Completion Date may be revised only by the Engineer by issuing an extension of time.

Materials are all supplies, including consumables, used by the Contractor for incorporation in the Works and works of routine maintenance.

Plant is any integral part of the Works that shall have a mechanical, electrical, electronic, chemical, or biological function.

Routine Maintenance is the maintenance of activities of the completed structure for five years as specified in the Contract Data.

The “Site” shall mean the land and other places including water bodies more specifically mentioned in the special conditions of the tender, on, under in or through which the permanent works or temporary works are to be executed and any other lands and places provided by the Municipal Corporation for working space or any other purpose as may be specifically designated in the contract as forming part of the site.

Site Investigation Reports are those that were included in the bidding documents and are reports about the surface and subsurface conditions at the Site.

“Specification” shall mean the specification referred to in the tender and any modification thereof or addition or deduction thereto as may from time to time be furnished or approved in writing by the Engineer.

The Start Date/Commencement Date is given in the Contract Data. It is the date when the Contractor shall commence execution of the Works. It does not necessarily coincide with any of the Site Possession Dates.

A Nominated Sub-Contractor is a person or corporate body who has a Contract with the Contractor to carry out a part of the construction work and/or routine maintenance in the Contract, which includes work on the Site.

Temporary Works are works designed, constructed, installed, and removed by the Contractor that are needed for construction or installation of the Works.

Variation means a change to the:-

- i) Specification and /or Drawings (if any) which is instructed by the Employer.
- ii) Scope in the Contract which is instructed by the Employer.
- iii) Price in the Contract which is instructed by the Employer.

The Works, as defined in the Contract Data, are what the Contract requires the Contractor to construct, install, maintain, and turn over to the Employer. Routine maintenance is defined separately.

Jurisdiction: In case of any claim, dispute or difference arising in respect of a contract, the cause of action thereof shall be deemed to have arisen in Mumbai and all legal proceedings in respect of any claim, dispute or difference shall be instituted in a competent court in the City of Mumbai only.

2. Interpretation

- 2.1 In interpreting these Conditions of Contract, singular also means plural, male also means female or neuter, and the other way around. Headings have no significance. Words have their normal meaning under the language of the Contract unless specifically defined. The Engineer will provide instructions clarifying queries about these Conditions of Contract.
- 2.2 If sectional completion is specified in the Contract Data, references in the Conditions of Contract to the Works, the Completion Date, and the Intended Completion Date apply to any Section of the Works (other than references to the Completion Date and Intended Completion Date for the whole of the Works).
- 2.3 The documents forming the Contract shall be interpreted in the following documents: (1) Agreement, (2) Letter of Acceptance, (3) Notice to Proceed with the Work, (4) Contractor's Bid, (5) Contract Data, (6) Special Conditions of Contract Part (7) General Conditions of Contract Part I, (8) Specifications, (9) Drawings, (10) Bill of Quantities, and (11) Any other document listed in the Contract Data.

3 . Engineer's Decisions

- 3.1 Except where otherwise specifically stated, the Engineer will decide contractual matters between the Employer and the Contractor in the role representing the Employer. However, if the Engineer is required under the rules and regulations and orders of the Employer to obtain prior approval of some other authorities for specific actions, he will so obtain the approval, before communicating his decision to the Contractor.

3.2 Except as expressly stated in the Contract, the Engineer shall not have any authority to relieve the Contractor of any of his obligations under the contract.

4. Delegation

4.1 The Engineer, with the approval of the Employer, may delegate any of his duties and responsibilities to other person(s), except to the Adjudicator, after notifying the Contractor, and may cancel any delegation after notifying the Contractor.

5. Communications

All certificates, notices or instructions to be given to the Contractor by Employer/ Engineer shall be sent on the address or contact details given by the Contractor of Bid. The address and contact details for communication with the Employer/ Engineer shall be as per the details given in Contract Data. Communications between parties that are referred to in the conditions shall be in writing. The Notice sent by facsimile (fax) or other electronic means shall be effective on confirmation of the transmission. The Notice sent by Registered post or Speed post shall be effective on delivery or at the expiry of the normal delivery period as undertaken by the postal service.

6. Subcontracting

6.1 Unless specifically mentioned in the contract subletting will not be allowed. Subletting, where otherwise provided by the contract shall not be more than 25% of the contract price.

6.2 The Contractor shall not be required to obtain any consent from the Employer for:

- a. the sub-contracting of any part of the Works for which the Subcontractor is named in the Contract;
- b. The provision for labour, or labour component.
- c. The purchase of Materials which are in accordance with the standards specified in the Contract.

6.3 Beyond what has been stated in clauses 6.1 and 6.2, if the Contractor proposes sub contracting any part of the work during execution of the Works, because of some unforeseen circumstances to enable him to complete the Works as per terms of the Contract, the Employer will consider the following before according approval:

- a. The Contractor shall not sub-contract the whole of the Works.
- b. The permitted subletting of work by the Contractor shall not establish any contractual relation-ship between the sub-contractor and the MCGM and shall not relieve the Contractor of any responsibility under the Contract.

6.4 The Engineer should satisfy himself before recommending to the Employer whether

- a. the circumstances warrant such sub-contracting; and
- b. the sub-Contractor so proposed for the Work possesses the experience, qualifications and equipment necessary for the job proposed to be entrusted to him.

7. Other Contractors

7.1 The Contractor shall cooperate and share the Site with other Contractors, public authorities, utilities, and the Employer between the dates given in the Schedule of Other Contractors, as referred to in the Contract Data. The Contractor shall also provide facilities and services for them as described in the Schedule. The Employer may modify the Schedule of Other Contractors, and shall notify the Contractor of any such modification.

7.2 The Contractor should take up the works in convenient reaches as decided by the Engineer to ensure there is least hindrance to the smooth flow and safety of traffic including movement of vehicles and equipment of other Contractors till the completion of the Works.

8. Personnel

8.1 The Contractor shall employ for the construction work and routine maintenance the key personnel including technical personnel named in the Contract Data or other personnel approved by the Engineer. The Engineer

will approve any proposed replacement of technical personnel only if their relevant qualifications and abilities are substantially equal to those of the personnel stated in the Contract Data.

8.2 The Contractor's personnel shall appropriately be qualified, skilled and experienced in their respective trades or occupations. The Engineer shall have authority to remove, or cause to be removed, any person employed on the site or works, who carries out duties incompetently or negligently and persists in any conduct which is prejudicial to safety, health or the protection of the environment.

8.3 If the Engineer asks the Contractor to remove a person who is a member of the Contractor's staff or work force, stating the reasons, the Contractor shall ensure that the person leaves the Site within seven days and has no further connection with the Works in the Contract.

8.4 The Contractor shall not employ any retired Gazetted officer who has worked in the Engineering Department of the MCGM /State Government and has either not completed two years after the date of retirement or has not obtained MCGM/State Government's permission to employment with the Contractor.

9. Employer's and Contractor's Risks

9.1 The Employer carries the risks which this Contract states are Employer's risks, and the Contractor carries the risks which this Contract states are Contractor's risks.

10. Employer's Risks

10.1 The Employer is responsible for the excepted risks which are (a) in so far as they directly affect the execution of the Works in the Employer's country, the risks of war, invasion, act of foreign enemies, rebellion, revolution, insurrection or military or usurped power, civil war, riot, commotion or disorder (unless restricted to the Contractor's employees)

and contamination from any nuclear fuel or nuclear waste or radioactive toxic explosive, or (b) a cause due solely to the design of the Works, other than the Contractor's design.

11. Contractor's Risks

11.1 All risks of loss of or damage to physical property and of personal injury and death which arise during and in consequence of the performance of the Contract other than the excepted risks, referred to in clause 11.1, are the responsibility of the Contractor.

12. Insurance

12.1 The Contractor at his cost shall provide, in the joint names of the Employer and the Contractor, insurance cover from the Start Date to the end of Defects Liability Period, in the amounts and deductibles stated in the Contract Data for the following events which are due to the Contractor's risks:

- a) Loss of or damage to the Works, Plant and Materials;
- b) Loss of or damage to Equipment;
- c) Loss of or damage to property (other than the Works, Plant, Materials, and Equipment) in connection with the Contract; and
- d) Personal injury or death.

12.2 Insurance policies and certificates for insurance shall be delivered by the Contractor to the Engineer for the Engineer's approval before the Start Date. All such insurance shall provide for compensation to be payable in the types and proportions of currencies required to rectify the loss or damage incurred.

12.3 Alterations to the terms of insurance shall not be made without the approval of the Engineer.

12.4 Both parties shall comply with any conditions of the insurance policies.

12.5 If the Contractor does not provide any of the policies and certificates required, the Employer may affect the insurance which the Contractor should have provided and recover the premiums the Employer has paid,

from payments otherwise due to the Contractor or if no payment is due, the payment of premiums shall be debt due.

13. Site Investigation Reports

13.1 The Contractor, in preparing the Bid, may rely, at his own risk, on any Site Investigation Reports referred to in the Contract Data, supplemented by any other information available to him, before submitting the bid.

14. Queries about the Contract Data

14.1 The Engineer will clarify queries on the Contract Data.

15. Contractor to Construct the Works and Undertake Maintenance (if specified in the tender)

15.1 The Contractor shall construct, and install and maintain the Works in accordance with the Specifications and Drawings and as per instructions of the Engineer.

15.2 The Contractor shall construct the works with intermediate technology, i.e., by manual means with medium input of machinery required to ensure the quality of works as per specifications. The Contractor shall deploy the equipment and machinery as required in the contract.

15.3 The Contractor shall take all reasonable steps to protect the environment he Site and to avoid damage or nuisance to persons or to property of the public or others resulting from pollution, noise or other causes arising as a consequence of his methods of operation.

During continuance of the contract, the Contractor and his sub-contractors shall abide at all times by all existing enactments on environmental protection and rules made there under, regulations, notifications and byelaws of the State or Central Government, or local authorities and any other law, bye-law, regulations that may be passed or notification that may be issued in future by the State or Central Government or the local authority. Salient features of some of the major laws that are applicable are given below:

- The Water (Prevention and Control of Pollution) Act, 1974, this provides for the prevention and control of water pollution and the maintaining and restoring of wholesomeness of water. 'Pollution' means such contamination of water or such alteration of the physical, chemical or biological properties of water or such discharge of any sewage or trade effluent or of any other liquid, gaseous or solid substance into water (whether directly or indirectly) as may, or is likely to, create a nuisance or render such water harmful or injurious to public health or safety, or to domestic, commercial, industrial, agricultural or other legitimate uses, or to the life and health of animals or plants or of aquatic organisms.
- The Air (Prevention and Control of Pollution) Act, 1981, this provides for prevention, control and abatement of air pollution. 'Air Pollution' means the presence in the atmosphere of any 'air pollutant', which means any solid, liquid or gaseous substance (including noise) present in the atmosphere in such concentration as may be or tend to be injurious to human beings or other living creatures or plants or property or environment.
- The Environment (Protection) Act, 1986, this provides for the protection and improvement of environment and for matters connected therewith, and the prevention of hazards to human beings, other living creatures, plants and property. 'Environment' includes water, air and land and the inter-relationship which exists among and between water, air and land, and human beings, other living creatures, plants, micro-organism and property.
- The Public Liability Insurance Act, 1991, This provides for public liability insurance for the purpose of providing immediate relief to the persons affected by accident occurring while handling hazardous substances and for matters connected herewith or incidental thereto. Hazardous substance means any substance or preparation which is defined as hazardous substance under the Environment (Protection) Act 1986, and exceeding such quantity as may be specified by notification by the Central Government.

16. The Works and Routine Maintenance to be completed by the Intended Completion Date

16.1 The Contractor may commence execution of the Works on the Start Date and shall carry out the Works and Routine Maintenance, if specified in the tender, in accordance with the Programme submitted by the Contractor, as updated with the approval of the Engineer, and complete them by the Intended Completion Date.

17. Approval by the Engineer

17.1 The Contractor shall submit Specifications and Drawings showing the proposed Temporary Works to the Engineer, who is to approve them if they comply with the Specifications and Drawings.

17.2 The Contractor shall be responsible for design and safety of Temporary Works.

17.3 The Engineer's approval shall not alter the Contractor's responsibility for design and safety of the Temporary Works.

17.4 The Contractor shall obtain approval of third parties to the design of the Temporary Works, where required.

17.5 All Drawings prepared by the Contractor for the execution of the temporary or permanent Works, are subject to prior approval by the Engineer before their use.

18. Safety

18.1 The Contractor shall be responsible for the safety of all activities on the Site. He shall comply with all applicable safety requirements and take care of safety of all persons entitled to be on the site and the works. He shall use reasonable efforts to keep the site and the works, both during construction and maintenance, clear of unnecessary obstruction so as to avoid danger to the persons and the users.

- Workers employed on mixing asphaltic materials, cement and lime mortars shall be provided with protective footwear and protective goggles.
- Stone breaker shall be provided with protective goggles and protective clothing and seated at sufficiently safe intervals.
- The area should be barricaded or cordoned off by suitable means to avoid mishaps of any kind. Power warning signs should be displayed for the safety of the public whenever cleaning works are undertaken during night or day.
- The workers engaged for cleaning the manholes/sewers should be properly trained before allowing working in the manhole.

18.2 Safety Programs:-

- Have adequate safety supervision in place to ensure that safety programs set up by the firms/agencies are in compliance with prevalent laws and regulations.
- Review safety programs developed by each of the trade firms, prepare and submit a comprehensive safety program.
- Monitor day to day implementation of safety procedures.

18.3 First Aid Facilities: -

- i. At every work place there shall be provided and maintained, so as to be easily accessible during working hours, first-aid boxes at the rate of not less than one box for 150 contract labour or part thereof ordinarily employed.
- ii. The first-aid box shall be distinctly marked with a red cross on white back ground.
- iii. Adequate arrangements shall be made for immediate recoupment of the equipment when necessary.
- iv. Nothing except the prescribed contents shall be kept in the First-aid box.

- v. The first-aid box shall be kept in charge of a responsible person who shall always be readily available during the working hours of the work place.
- vi. A person in charge of the First-aid box shall be a person trained in First-aid treatment, in the work places where the number of contract labour employed is 150 or more.

19. Discoveries

19.1 Anything of historical or other interest or of significant value unexpectedly discovered on the Site shall be the property of the Employer. The Contractor shall notify the Engineer of such discoveries and carry out the Engineer's instructions for dealing with them.

20. Possession of the Site

20.1 The Employer shall handover complete or part possession of the site to the Contractor 7 days in advance of construction programme. At the start of the work, the Employer shall handover the possession of at-least 75% of the site free of all encumbrances, the remaining 25 % of the possession as per contractor's construction programme.

21. Access to the Site

21.1 The Contractor shall allow access to the Site and to any place where work in connection with the Contract is being carried out, or is intended to be carried out to the Engineer and any person/persons/agency authorized by: a. The Engineer b. The Employer or authorized by the Employer.

22. Instructions

- 22.1 The Contractor shall carry out all instructions of the Engineer, which comply with the applicable laws where the Site is located.
- 22.2 The Contractor shall permit the appointed and/or authorized persons to inspect the Site and/or accounts and records of the Contractor and its subcontractors relating to the performance of the Contract, and to have such accounts and records audited by auditors appointed, if so required.

The Contractor's attention is invited to Clause of 'Fraud and Corruption', which provides, inter alia, that acts intended to materially impede the exercise of the inspection and audit rights provided for under the Clause & constitute a obstructive practice subject to contract termination.

22.3 Engineer to have power to issue further drawings or instructions:

The Engineer shall have the power and authority from time to time and at all times to make and issue such further drawings and to give such further instructions and directions as may appear to him necessary or proper for the guidance of the contractor and the good and sufficient execution of the works according to terms of the specifications and Contractor shall receive, execute, obey and be bound by the same, according to the true intent and meaning thereof, as fully and effectually as though the same had accompanied or had been mentioned or referred to in the specification, and the Engineer may also alter or vary the levels or position of nature of works contemplated by the specifications, or may order any of the works contemplated thereby to be omitted, with or without the substitution of any other works in lieu thereof, or may order any work or any portion of work executed or partially executed, to be removed, changed or altered, added if needful, may order that other works shall be substituted instead thereof and difference of expense occasioned by any such diminution or alteration so ordered and directed shall be added to or deducted from the amount of this Contract, as provided under condition no.10(a) hereinafter.

No work which radically changes the original nature of the Contract shall be ordered by the Engineer and in the event of any deviation being ordered which in the opinion of the Contractor changes the original nature of Contract he shall nevertheless carry it out and disagreement as to the nature of the work and the rate to be paid therefore shall be resolved in accordance with condition no.13d.

The time for completion of the Works, shall be in even of any deviations resulting in additional cost over the contract price being ordered, be extended or reduced reasonably by the Engineer. The Engineer's decision in this case shall be final.

B. Time Control

23. Programme

23.1 Within the time stated in the Contract Data, the Contractor shall submit to the Engineer for approval a Programme, including Environment Management Plan showing the general methods, arrangements, order, and timing for all the activities in the Works, along with monthly cash flow forecasts for the construction of works.

After the completion of the construction works, the programme for the Routine Maintenance Work, showing the general methods, arrangements, order and timing for all the activities involved in the Routine Maintenance will also be submitted by the Contractor to the Engineer for approval if specified in the tender. The programme for Routine Maintenance will be submitted in each year for the period of Maintenance.

23.2 The Contractor shall submit the list of equipment and machinery being brought to site, the list of key personnel being deployed, the list of machinery/ equipments being placed in field laboratory and the location of field laboratory along with the Programme. The Engineer shall cause these details to be verified at each appropriate stage of the programme.

23.3 An update of the Programme shall be a programme showing the actual progress achieved on each activity and the effect of the progress achieved on the timing of the remaining Works, including any changes to the sequence of the activities.

23.4 The Contractor shall submit to the Engineer for approval an updated Programme at intervals no longer than the period stated in the Contract Data. If the Contractor does not submit an updated Programme within this period, the Engineer may withhold the amount stated in the Contract Data from the next payment certificate and continue to withhold this amount until the next payment after the date on which the overdue Programme has been submitted.

23.5 The Engineer's approval of the Programme shall not alter the Contractor's obligations. The Contractor may revise the Programme and submit it to the Engineer again at any time. A revised Programme shall show the effect of Variations and Compensation Events.

24. Extension Of Time In Contracts:

Subject to any requirement in the contract as to completion of any portions or portions of the works before completion of the whole, the contractor shall fully and finally complete the whole of the works comprised in the contract (with such modifications as may be directed under conditions of this contract) by the date entered in the contract or extended date in terms of the following clauses:

a) Extension attributable to MCGM

- (i) Extension Due To Modification: If any modifications have been ordered which in the opinion of the Engineer have materially increased the magnitude of the work, then such extension of the contracted date of completion may be granted as shall appear to the Engineer to be reasonable in the circumstances, provided moreover that the Contractor shall be responsible for requesting such extension of the date as may be considered necessary as soon as the cause thereof shall arise and in any case should not be less than 30 days before the expiry of the date fixed for completion of the works.
- (ii) Extension For Delay Due To MCGM: In the event of any failure or delay by the MCGM to hand over the Contractor possession of the lands necessary for the execution of the works or to give the necessary notice to commence the works or to provide the necessary drawings or instructions or any other delay caused by the MCGM due to any other cause whatsoever, then such failure or delay shall in no way affect or vitiate the contract or alter the character thereof or entitle the contractor to damages or compensation therefore, but in any such case, the MCGM may grant such extension(s) of the completion date as may be considered reasonable.

Note: For extension of time period as governed in (i) and (ii) above, any modifications in design/drawings, specifications, quantities shall be needed to be justified with recorded reasons with approval of Ch.Eng. for not anticipating the same while preparing estimates and draft tender.

- b) **Extension Of Time For Delay Due To Contractor:** The time for the execution of the work or part of the works specified in the contract documents shall be deemed to be the essence of the contract and the works must be completed no later than the date(s) / the programme for completion of work as specified in the contract. If the contractor fails to complete the works within the time as specified in the contract for the reasons other than the reasons specified in above as (a.i) and (a.ii), the MCGM may, if satisfied that the works can be completed by the contractor within reasonable short time thereafter, allow the contractor for further extension of time as the Engineer may decide. On such extension the MCGM will be entitled without prejudice to any other right and remedy available on that behalf, to recover the compensation as governed by Clause 8(e) of GCC.

For the purpose of this Clause, the contract value of the works shall be taken as value of work as per contract agreement including any supplementary work order/contract agreement issued.

Further, competent authority while granting extension to the currency of contract under Clause (b) of as above may also consider levy of penalty, as deemed fit based on the merit of the case. Also, the reasons for granting extension shall be properly documented.

25. Delays Ordered by the Engineer

- 25.1 The Engineer may instruct the Contractor to delay the start or progress of any activity within the Works. Delay/delays totalling more than 30 days will require prior written approval of the DMC/AMC.

26. Management Meetings

- 26.1 The Engineer may require the Contractor to attend a management meeting. The business of a management meeting shall be to review the plans for progress of the Works.
- 26.2 The Engineer shall record the business of management meetings and provide copies of the record to those attending the meeting. The responsibility of the parties for actions to be taken shall be decided by the Engineer either at the management meeting or after the management meeting and stated in writing to all those who attended the meeting.

C. Quality Control

- 27.1. **Work to be open to Inspection and Contractor or Responsible agent to be present:** All works under or in course of execution or executed in pursuance of the contract shall at all times be open to the inspection and supervision of the Eng-in-charge and his subordinates and the contractor shall at all times during the usual working hours, at all other times, during the usual working hours and at all other times at which reasonable notice of the intention of the Eng-in-charge and his subordinates to visit the works shall have been given to the contractor, either himself be present to receive orders and instruction or have responsible agent duly accredited in writing present for that purpose. Order given to the contractors' duly authorized agent shall be considered to have the same force and effect as if they had been given to the contractor himself.
- 27.2. **Notice To Be Given Before Work Is Covered Up:**
The contractor shall give not less than ten days' notice in writing to the Eng-In-Charge or his subordinate in charge of the work before covering up or otherwise placing beyond the reach of measurement any work in order that the same may be measured and correct dimension thereof taken before the same is so covered up or placed beyond the reach of measurements and shall not cover up or place beyond the reach of measurement any work without the consent in writing of the Eng-In-Charge or his subordinate incharge of the work, and if any work shall be covered up or placed beyond the reach of measurement, without such notice having been given or consent

obtained the same shall be uncovered at the contractors expenses, and in default thereof no payment or allowance shall be made for such work or for the materials with which the same was executed.

27.3 Works to be executed in accordance with specifications / drawings / orders etc. :

The contractor shall execute the whole and every part of the work the most substantial and workman like manner and both has regards material and every other respect in strict accordance with specifications. The contractor shall also confirm exactly, fully and faithfully to the designs, drawings and instructions in writing relating to the work signed by the Engineer In-charge and lodged in his office and to which the contractor shall be entitled to have access for the purpose of inspection at such office, or on the site or work during office hours. The contractor shall be entitled to receive three sets of contract drawings and working drawings as well as one certified copy of the accepted tender along with the work order free of cost.

27.4 Ready Mix Concrete/ Asphalt Mix:

- i) The contractor shall have to arrange Ready Mix concrete (RMC)/Asphalt from RMC/ASPHALT producing plants registered with MCGM
- ii) The contractor shall, within a7 days of award of the work, submit a list of at least three RMC/Asphalt producers with details of such plants including details and number of transit, mixers & pumps etc. to be deployed indicating name of owner/company, its location, capacity, technical establishment.

The Engineer-in-charge will reserve right to inspect at any stage and reject the concrete if he is not satisfied about quality of product at the user's end.

- iii) The Engineer-in-charge reserves the right to exercise control over the:-
 - a) Calibration check of the RMC/Asphalt plant.
 - b) Weight and quantity check on the ingredients, water and admixtures added for batch mixing for RMC plants
 - c) Time of mixing of concrete/grade of asphalt.

- d) Testing of fresh concrete/asphalt mix, recording of results and declaring the mix fit or unfit for use. This will include continuous control on the work ability during production and taking corrective action, if required.
- e) For exercising such control, the Engineer-in-charge shall periodically depute his authorized representative at the RMC/Asphalt plant. It shall be responsibility of the contractor to ensure that all necessary equipment, manpower & facilities are made available to Engineer-in-charge and or his authorized representative at RMC/Asphalt plant.
- f) All required relevant records of RMC/Asphalt mix shall be made available to the Engineer-in-charge or his authorized representative. Engineer-in-charge shall, as required, specify guidelines & additional procedures for quality control & other parameters in respect of material production& transportation of concrete mix which shall be binding on the contractor & the RMC/Asphalt plant. Only concrete as approved in design mix by Engineer-in-charge shall be produced in RMC plant and transported to the site.
- g) The contractor shall have to produce a copy of chalan receipts/SCADA reports/VTS reports as issued by the RMC/Asphalt plant as a documentary proof in lieu of supply of RMC/Asphalt mix before releasing payment.

28. Identifying Defects

- 28.1 The Engineer shall check the Contractor's work and notify the Contractor of any Defects that are found. Such checking shall not affect the Contractor's responsibilities. The Engineer may instruct the Contractor to search for a Defect and to uncover and test any work that the Engineer considers may have a Defect.
- 28.2 The Contractor shall permit the Employer's technical person(s) to check the Contractor's work and notify the Engineer and Contractor if any defects that are found.

29. Tests

29.1 For carrying out mandatory tests as prescribed in the specifications, the Contractor shall establish field laboratory at the location decided by Engineer. The field laboratory will have minimum of equipments as specified in the Contract Data. The contractor shall be solely responsible for:

- a. Carrying out the mandatory tests prescribed in the Specifications, and
- b. For the correctness of the test results, whether performed in his laboratory or elsewhere.

29.2 If the Engineer instructs the Contractor to carry out a test not specified in the Specification/ Quality Assurance Handbook to check whether any work has a Defect and the test shows that it does, the Contractor shall pay for the test and any samples. If there is no defect, the test shall be a compensation event.

When required by the Engineer-in-charge the contractor(s) shall supply for the purpose of testing samples of all materials proposed to be used in the works. Samples submitted either to govern bulk supplies or required for testing before use shall be in suitable packages to contain them and shall be provided free of charge by the contractor. The cost of testing shall be borne by the contractor even if the result of the sample confirm or do not confirm to the relevant BIS code specifications.

- i. All expenditure required to be incurred for taking the samples conveyance, packing shall be borne by the contractor himself.
- ii. The failed material shall be removed from the site by the contractor at his own cost within a week time of written order of the Engineer-in-charge.

29.3 Setting of Site Laboratories:

Contractors shall set up a laboratory at site before commencement of work at their cost for performing various tests and at least the following machines and equipments shall be provided therein –

1. Set of Sieves as per I.R.C. /I.S.
2. Compressive Testing Machine(For new works)
3. Oven, Electrically Operated
4. Weighing Balance (20 kg capacity)
5. 3 m straight edge
6. Sieve shaker
7. First Aid Box
8. Measuring Jar (for silt content)
9. Other Machines/apparatus as may be directed by the Engineer
10. Vernier Caliper
11. Level / Theodolite

All the test records shall be maintained in the site office and made available as and when required. The laboratory must be established within 15 days from the date of receipt of the orders from Engineer In charge. On failure to do so, a penalty of Rs 1000/- per day shall be imposed.

The contractor shall install testing equipment at site. The contractor shall ensure and certify the calibration of the equipment so installed and shall maintain the same in working order throughout the period of construction. The contractor shall also provide necessary technically qualified experienced trained staff for carrying out such tests for using such equipment. The tests shall be carried out under the supervision of the Engineer-in-charge. The calibration shall be checked every twelve months as directed by Engineer-in-charge.

30. Correction of Defects noticed during the Defects Liability Period.

- 30.1 (a) The Engineer shall give notice to the Contractor of any Defects before the end of the Defects Liability Period, which begins at Completion and ends after five years. The Defects Liability Period shall be extended for as long as Defects remain to be corrected.

- (b) Every time notice of Defect/Defects is given, the Contractor shall correct the notified Defect/Defects within the duration of time specified by the Engineer's notice.
- (c) The Engineer may issue notice to the Contractor to carry out removal of defects or deficiencies, if any, noticed in his inspection, or brought to his notice. The Contractor shall remove the defects and deficiencies within the period specified in the notice and submit to the Engineer a compliance report.

31. Uncorrected Defects and Deficiencies

- 31.1 If the Contractor has not corrected a Defect pertaining to the Defect Liability Period under clause and deficiencies in maintenance, to the satisfaction of the Engineer, within the time specified in the Engineer's notice, the Engineer will assess the cost of having the Defect or deficiency corrected, and the Contractor shall pay this amount, on correction of the Defect or deficiency by another agency.

D. Cost Control

32. Variations

The Engineer shall, having regard to the scope of the Works and the sanctioned estimated cost, have power to order, in writing, Variations within the scope of the Works he considers necessary or advisable during the progress of the Works. Such Variations shall form part of the Contract and the Contractor shall carry them out and include them in updated Programmes produced by the Contractor. Oral orders of the Engineer for Variations, unless followed by written confirmation, shall not be taken into account.

33. Payments for Variations

33.1 If rates for Variation items are specified in the Bill of Quantities, the Contractor shall carry out such work at the same rate.

33.2 The rate for Extra/Excess shall be governed by clause 10.A of Standard General Condition of Contract

34. Cash Flow Forecasts

When the Programme is updated, the Contractor shall provide the Engineer with an updated cash flow forecast.

35. Payment Certificates

The payment to the Contractor will be as follows for construction work:

- (a) A bill shall be submitted by the Contractor monthly or before the date fixed by the Engineer In-charge for all works executed in the previous month, and the Engineer In-charge shall take or cause to be taken requisite measurement for the purpose of having the same verified and the claim, so far as it is admissible, shall be adjusted, if possible, within 10 days from the presentation of the bill. If the contractor does not submit the bill within the time fixed as aforesaid, the Engineer In-charge may depute a subordinate to measure up the said work in the presence of the contractor or his duly authorized agent whose counter signature to the measurement list shall be sufficient warrant, and Engineer In-Charge may prepare a bill from such list which shall be binding on the contractor in all respects.
- (b) The Engineer shall check the Contractor's fortnightly/monthly statement within 14 days and certify the amount to be paid to the Contractor.
- (c) The value of work executed shall be determined, based on measurements by the Engineer.
- (d) The value of work executed shall comprise the value of the quantities of the items in the Bill of Quantities completed.
- (e) The value of work executed shall also include the valuation of Variations and CompensationEvents.

- (f) The Engineer may exclude any item certified in a previous certificate or reduce the proportion of any item previously certified in any certificate in the light of later information. (g) The contractor shall submit all bills on the printed forms at the office of Engineer In-charge. The charges to be made in the bills shall always be entered at the rates specified in tender.

36 Payments

- 36.1 Payments shall be adjusted for deductions for advance payments, retention, security deposit, other recoveries in terms of the Contract and taxes at source, as applicable under the law. The Employer shall pay the Contractor the amounts certified by the Engineer within 15 days of the date of each certificate.
- 36.2 All sums payable by a contractor by way of compensation under any of these conditions, shall be considered as a reasonable compensation to be applied to the use of MCGM without reference to the actual loss or damage sustained and whether any damage has or has not been sustained.
- 36.3 No payment shall be made for any work estimated to cost less than Rupees One Thousand till after the whole of work shall have been completed and the certificate of completion given. But in the case of works estimated to cost more than Rs. One Thousand, the contractor shall on submitting a monthly bill therefore be entitled to receive payment proportionate to the part of the work than approved and passed by the Engineer In-charge, whose certificate of such approval and passing of the sum so payable shall be final and conclusive against the contractor. All such intermediate payments shall be regarded as payments by way of advance against the final payments only and not as payments for work actual done and completed and shall not preclude the Engineer In-charge from requiring any bad, unsound, imperfect or unskilful work to be removed or taken away and reconstructed or re-erected nor shall any such payment be considered as an admission of the due performance of the contract or any part thereof in any respect or

the offering of any claim not shall it conclude, determine or effect in any other way, the powers of the Engineer In-charge as to the final settlement and adjustment of the accounts or otherwise, or in any other way vary or effect the contract. The final bill shall be submitted by the Contractor within one month of the date fixed for the completion of the work otherwise the Engineer In-charge's certificate of the measurements and of the total amount payable for the work shall be final and binding on all parties.

37. The Contractor shall not be entitled to compensation to the extent that the Employer's interests are adversely affected by the Contractor for not having given early warning or not having cooperated with the Engineer.

38. Tax

G.S.T. and other state levies/cess which are not subsumed under GST will be applicable. The tenderer shall quote inclusive of all taxes applicable at the time of bid submission. It is clearly understood that MCGM will not bear any additional liability towards payment of any Taxes & Duties.

Wherever the Services to be provided by the Tenderers falls under Reverse Charge Mechanism, the Price quoted shall be exclusive of GST, but inclusive of Taxes / Duties / Cess other than GST, if any.

Rates accepted by MCGM shall hold good till completion of work and no additional individual claim shall be admissible on account of fluctuations in market rates; increase in taxes/any other levies/tolls etc. except that payment/recovery for overall market situation shall be made as per price Variation and if there is any subsequent change(after submission of bid) in rate of GST applicable on the works/services to be executed as per tender i.e any increase will be reimbursed by BMC whereas any reduction in the rate of GST shall be passed on to BMC as per the provisions of the GST Act.

"Chapter XXI-Miscellaneous, section 171(1) of GST Act,2017 governs the 'Anti Profiteering Measure'(APM).

As per the provision of this section,' Any reduction in rate of tax on any supply of goods or services or the benefit of input tax credit shall be passed on to the recipient by way of commensurate reduction in prices'.

Accordingly, the contractor should pass on the complete benefit accruing to him on account of reduced tax rate or additional input tax credit, to MCGM.

Further, all the provisions of GST Act will be applicable to the tender."

Circular u/no CA/F/ Project/26 dt. 28.07.2022 and Circular u/no CA/F/ Project/25 dt. 12.07.2022 will be applicable.

- 39. Currencies:**All payments will be made in Indian Rupees.

40. Liquidated Damages

Both, the Contractor and the Employer have agreed that it is not feasible to precisely estimate the amount of losses due to delay in completion of works and the losses to the public and the economy, therefore, both the parties have agreed that the Contractor shall pay liquidated damages to the Employer and not by way of penalty, at the rate per week or part thereof stated in the Contract Data for the period that the Completion Date is later than the Intended Completion Date. Liquidated damages at the same rates shall be withheld if the Contractor fails to achieve the milestones prescribed in the Contract Data. However, in case the Contractor achieves the next milestone, the amount of the liquidated damages already withheld shall be restored to the Contractor by adjustment in the next payment certificate. The Employer and the contractor have agreed that this is a reasonable agreed amount of liquidated damage. The Employer may deduct liquidated damages from payments due to the Contractor. Payment of liquidated damages shall not affect the Contractor's other liabilities.

41. Cost of Repairs

Loss or damage to the Works or Materials to be incorporated in the Works between the Start Date and the end of the Defects Correction periods shall be remedied by the Contractor at his cost if the loss or damage arises from the Contractor's acts or omissions.

E. Finishing the Contract

42. Completion of Construction and Maintenance

42.1 The Contractor shall request the Engineer to issue a certificate of completion of the construction of the works, and the Engineer will do so upon deciding that the works is completed. This shall be governed as per clause no.8 (g) of Standard General Conditions of Contract.

43. Taking Over

43.1 The Employer shall take over the works within seven days of the Engineer issuing a certificate of completion of works. The Contractor shall continue to remain responsible for its routine maintenance during the maintenance period if specified in the contract.

44. Final Account

Final joint measurement along-with the representatives of the contractor should be taken recorded and signed by the Contractors. Contractors should submit the final bill within 1 month of physical completion of the work.

If the contractor fails to submit the final bill within 1 month, the MCGM staff will prepare the final bill based on the joint measurement within next 3 months.

Engineer's decision shall be final in respect of claims for defect and pending claims against contractors.

No further claims should be made by the Contractor after submission of the final bill and these shall be deemed to have been waived and extinguished. Payment of those items of the bills in respect of which there is no dispute and of items in dispute, for quantities and rates as approved by the Commissioner shall be made within a reasonable period as may be necessary for the purpose of verification etc.

After payment of the final bill as aforesaid has been made, the contractor may, if he so desires, reconsider his position in respect of a disputed portion of the final bills and if he fails to do so within 84 days, his disputed claim shall be dealt with as provided in the contract.

A percentage of the retention money, over and above the actual retention money as indicated below shall be held back from payments till the finalization of final bill to be submitted as per above and will be paid within 30 days of acceptance of the final bill.

Sr.no.	Amount of Contract Cost	Minimum Payable Amount in final bill
1	Upto Rs.5 Crs.	Rs.10 Lacs or final bill whichever is more
2	Upto Rs.25 Crs.	Rs.1 Crore or final bill amount whichever is more
3	UptoRs. 50 Crs.	Rs.2 Crores or final bill amount whichever is more

4	Upto Rs.100 Crs.	Rs.4 Crore or final bill amount whichever is more
5	More than Rs.100 Crs.	Rs.7 Crore or final bill amount whichever is more

The contractor have to submit the bill for the work carried out within 15 days from the date of completion of the work to the respective executing department. If the contractor fails to submit their bills to concerned executing department, penalty or action as shown below will be taken for each delayed bill:-

After 15 days from the date of completion/running bill upto certain date, upto next 15 days i.e. upto 30 days	Equal to 5% of bill amount
Next 15 days upto 45 days from the date of completion/running bill upto specified date	Equal to 10% of bill amount
If not submitted within 45 days from the date of completion/ R.A. bill	Bill will not be admitted for payment.

45. Operating and Maintenance Manuals

45.1 If "as built" Drawings and/or operating and maintenance manuals are required, the Contractor shall supply them by the dates stated in the Contract Data.

45.2 If the Contractor does not supply the Drawings and/or manuals by the dates stated in the Contract Data, or they do not receive the Engineer's approval, the Engineer shall withhold the amount stated in the Contract Data from payments due to the Contractor.

46. Termination

46.1 The Employer or the Contractor may terminate the Contract if the other party causes a fundamental breach of the Contract.

46.2 Fundamental breaches of Contract shall include, but shall not be limited to, the following:

- a) the Contractor stops work for 30 days when no stoppage of work is shown on the current Programme and the stoppage has not been authorized by the Engineer;
- b) the Contractor is declared as bankrupt or goes into liquidation other than for approved reconstruction or amalgamation;
- c) the Engineer gives Notice that failure to correct a particular Defect is a fundamental breach of Contract and the Contractor fails to correct it within a reasonable period of time determined by the Engineer;
- d) the Contractor does not maintain a Security, which is required;
- e) the Contractor has delayed the completion of the Works by the number of days for which the maximum amount of liquidated damages can be paid, as defined in relevant clause.
- f) the Contractor fails to provide insurance cover as required under relevant clause .
- g) if the Contractor, in the judgment of the Employer, has engaged in the corrupt or fraudulent practices as defined in GCC in competing for or in executing the Contract.
- h) if the Contractor fails to set up a field laboratory with the prescribed equipment, within the period specified in the Contract Data; and
- i) any other fundamental breaches as specified in the Contract Data.
- j) if the Contractor fails to deploy machinery and equipment or personnel as specified in the Contract Data at the appropriate time.

46.3 When either party to the contract gives notice of a breach of contract to the Engineer for a cause other than those listed above, the Engineer shall decide whether the breach is fundamental or not.

46.4 Notwithstanding the above, the Employer may terminate the Contract for convenience.

46.5 If the Contract is terminated, the Contractor shall stop work immediately, make the Site safe and secure, and leave the Site as soon as reasonably possible.

47. Payment upon Termination

47.1 If the Contract is terminated because of a fundamental breach of Contract by the Contractor, the Engineer shall issue a certificate for value of the work done and materials ordered less liquidated damages, if any, less advance payments received up to the date of the issue of the certificate and less the percentage to apply to the value of the work not completed, as indicated in the Contract Data. If the total amount due to the Employer exceeds any payment due to the Contractor, the difference shall be recovered from the security deposit, and performance security. If any amount is still left un-recovered it will be a debt due from the Contractor to the Employer

47.2 If the Contract is terminated at the Employer's convenience, the Engineer shall issue a certificate for the value of the work done, the reasonable cost of removal of Equipment, repatriation of the Contractor's personnel employed solely on the Works, and the Contractor's costs of protecting and securing the Works and less advance payments received up to the date of the certificate, less other recoveries due in terms of the Contract, and less taxes due to be deducted at source as per applicable law.

48. Property

48.1 All Materials on the Site, Plant, Equipment, Temporary Works, and Works shall be deemed to be the property of the Employer for use for completing balance construction work if the Contract is terminated because of the Contractor's default, till the Works is completed after which it will be transferred to the Contractor and credit, if any, given for its use.

49. Release from Performance

If the Contract is frustrated by the outbreak of war or by any other event entirely outside the control of the Employer or the Contractor, the Engineer shall certify that the Contract has been frustrated. The Contractor shall make the Site safe and stop work as quickly as possible after receiving this certificate and shall be paid for all work carried out before receiving it and for any work carried out afterwards to which a commitment was made.

A) Other Conditions of Contract

50. Labour

50.1 The Contractor shall, unless otherwise provided in the Contract, make his own arrangements for the engagement of all staff and labour, local or other, and for their payment, housing, feeding and transport.

50.2 The Contractor shall, if required by the Engineer, deliver to the Engineer a return in detail, in such form and at such intervals as the Engineer may prescribe, showing the staff and the number of the several classes of labour from time to time employed by the Contractor on the Site and such other information as the Engineer may require.

51. Compliance with Labour Regulations

(a) During continuance of the Contract, the Contractor and his sub-Contractors shall abide at all times by all existing labour enactments and rules made there under, regulations, notifications and bye laws of the State or Central Government or local authority and any other labour law (including rules), regulations, bye laws that may be passed or notification that may be issued under any labour law in future either by the State or the Central Government or the local authority.

(b) Furthermore, the Contractor shall keep the Employer indemnified in case any action is taken against the Employer by the competent authority on account of contravention of any of the provisions of any Act or rules made

there under, regulations or notifications including amendments. If the Employer is caused to pay or reimburse, such amounts as may be necessary to cause or observe, or for non-observance of the provisions stipulated in the notifications/bye laws/Acts/Rules/regulations including amendments, if any, on the part of the Contractor, the Engineer/Employer shall have the right to deduct any money due to the Contractor including his amount of performance guarantee. The Employer/Engineer shall also have right to recover from the Contractor any sum required or estimated to be required for making good the loss or damage suffered by the Employer.

(c) The Contractor shall require his employees to obey all applicable laws, including those concerning safety at work.

(d) The employees of the Contractor and the Sub-Contractor in no case shall be treated as the employees of the Employer at any point of time.

52. Drawings and Photographs of the Works

52.1 The Contractor shall do photography/video photography of the site firstly before the start of the work, secondly mid-way in the execution of different stages of work as required by Engineer In-charge and lastly after the completion of the work. No separate payment will be made to the Contractor for this.

52.2 The Contractor shall not disclose details of Drawings furnished to him and works on which he is engaged without the prior approval of the Engineer in writing. No photograph of the works or any part thereof or plant employed thereon, except those permitted under above clause, shall be taken or permitted by the Contractor to be taken by any of his employees or any employees of his sub-Contractors without the prior approval of the Engineer in writing. No photographs/ Video photography shall be published or otherwise circulated without the approval of the Engineer in writing.

53. The Apprentices Act, 1961

The Contractor shall duly comply with the provisions of the Apprentices Act 1961 (III of 1961), the rules made there under and the orders that may be

issued from time to time under the said Act and the said Rules and on his failure or neglect to do so, he shall be subject to all liabilities and penalties provided by the said Act and said Rules.

54 Contract Document

The documents forming the contract are to be taken as mutually explanatory of one another. Unless otherwise provided in the contract, the priority of the documents forming the contract shall be, as follows:

- 1) Contract Agreement (if completed)
- 2) The letter of Acceptance
- 3) The Bid:
- 4) Addendum to Bid; if any
- 5) Tender Document
- 6) The Bill of Quantities:
- 7) The Specification:
- 8) Detailed Engineering Drawings
- 9) Standard General Conditions of Contracts (GCC)
- 10) All correspondence documents between bidder/contractor and MCGM.

55 Conflict of Interest

The Applicant shall not have a conflict of interest (the “Conflict of Interest”) that affects the Bidding Process. Any Applicant found to have a Conflict of Interest shall be disqualified. An Applicant shall be deemed to have a Conflict of Interest affecting the Bidding Process, if

1. A constituent of such Applicant is also a constituent of another Applicant; or
2. Such Applicant has the same legal representative for purposes of this Application as any other Applicant; or
3. Such Applicant, or any Associate thereof has a relationship with another Applicant, or any Associate thereof, directly or through common third party/ parties, that puts either or both of them in a position to have

access to each other's information about, or to influence the Application of either or each other; or

4. The Applicant shall be liable for disqualification if any legal, financial or technical adviser of the Authority in relation to the Project is engaged by the Applicant, its Member or any Associate thereof, as the case may be, in any manner for matters related to or incidental to the Project. For the avoidance of doubt, this disqualification shall not apply where such adviser was engaged by the Applicant, its Member or Associate in the past but its assignment expired or was terminated 6 (six) months prior to the date of issue of this TENDER. Nor will this disqualification apply where such adviser is engaged after a period of 3 (three) years from the date of commercial operation of the Project.

56. Applications and costs thereof

No Applicant shall submit more than one Application for the Project. An applicant applying individually shall not be entitled to submit another application either individually. The Applicant shall be responsible for all of the costs associated with the preparation of their Applications and their participation in the Bid Process. The Authority will not be responsible or in any way liable for such costs, regardless of the conduct or outcome of the Bidding Process.

57. Acknowledgment by Applicant

It shall be deemed that by submitting the Application, the Applicant has:

- a. made a complete and careful examination of the tender;
- b. received all relevant information requested from the Authority;
- c. accepted the risk of inadequacy, error or mistake in the information provided in the tender or furnished by or on behalf of the Authority relating to any of the matters referred; and
- d. Agreed to be bound by the undertakings provided by it under and in terms hereof. "The Authority" shall not be liable for any omission, mistake or error in respect of any of the above or on account of any matter or

thing arising out of or concerning or relating to the TENDER or the Bidding Process, including any error or mistake therein or in any information or data given by the Authority.

58. Right to accept or reject any or all Applications/ Bids

Notwithstanding anything contained in this TENDER, “The Authority” reserves the right to accept or reject any Application and to annul the Bidding Process and reject all Applications/ Bids, at any time without any liability or any obligation for such acceptance, rejection or annulment, and without assigning any reasons therefore. In the event that the Authority rejects or annuls all the Bids, it may, in its discretion, invite all eligible Bidders to submit fresh Bids hereunder.

“The Authority” reserves the right to reject any Application and/ or Bid if:

- a. at any time, a material misrepresentation is made or uncovered, or
- b. The Applicant does not provide, within the time specified by the Authority, the supplemental information sought by the Authority for evaluation of the Application.

In case it is found during the evaluation or at any time before signing of the Agreement or after its execution and during the period of subsistence thereof including the concession thereby granted by “The Authority”, that one or more of the pre-qualification conditions have not been met by the Applicant, or the Applicant has made material misrepresentation or has given any materially incorrect or false information, the Applicant shall be disqualified forthwith if not yet appointed as the Successful Bidder either by issue of the LOA (Letter of Approval) or entering into of the Agreement, and if the Applicant has already been issued the LOA or has entered into the Concession Agreement, as the case may be, the same shall, notwithstanding anything to the contrary contained therein or in this TENDER, be liable to be terminated, by a communication in writing by “The Authority” to the Applicant, without the Authority being liable in any manner whatsoever to the Applicant and without prejudice to any other right or remedy which the Authority may have under this TENDER, the Bidding Documents, the Concession Agreement or under applicable law.

“The Authority” reserves the right to verify all statements, information and documents submitted by the Applicant in response to the TENDER. Any such verification or lack of such verification by the Authority shall not relieve the Applicant of its obligations or liabilities hereunder nor will it affect any rights of the Authority there under.

59 The bid shall be rejected if the bidder-

- a. Stipulates the validity period less than 180 days.
- b. Stipulates own condition/conditions.
- c. Does not fill and (digital) sign undertaking forms, which are incorporated, in the document.

60 Clarifications

Applicants requiring any clarification on the tender may notify “the Authority” in writing or by fax or e-mail. They should send in their queries before the date specified in the header data. “The Authority” shall Endeavor to respond to the queries within the period specified therein. The responses will be sent by fax and/or e-mail. The Authority will forward all the queries and its responses thereto, to all purchasers of the TENDER without identifying the source of queries.

“The Authority” shall Endeavour to respond to the questions raised or clarifications sought by the Applicants. However, the Authority reserves the right not to respond to any question or provide any clarification, in its sole discretion, and nothing in this Clause shall be taken or read as compelling or requiring the Authority to respond to any question or to provide any clarification, but not later than the date provided in header data.

“The Authority” may also on its own motion, if deemed necessary, issue interpretations and clarifications to all Applicants. All clarifications and interpretations issued by the Authority shall be deemed to be part of the tender. Verbal clarifications and information given by Authority or its employees or representatives shall not in any way or manner be binding on the Authority.

61 Amendment of tender

At any time prior to the deadline for submission of Application, the Authority may, for any reason, whether at its own initiative or in response to clarifications requested by an Applicant, modify the tender by the issuance of Addendum.

Any Addendum thus issued will be sent in writing/ Fax/ Email to all those who have purchased the tender.

In order to afford the Applicants a reasonable time for taking an Addendum into account, or for any other reason, the Authority may, in its sole discretion, extend the Application Due Date.

Preparation and Submission of Application

62 Language

The Application and all related correspondence and documents in relation to the Bidding Process shall be in English language. Supporting documents and printed literature furnished by the Applicant with the Application may be in any other language provided that they are accompanied by translations of all the pertinent passages in the English language, duly authenticated and certified by the Applicant. Supporting materials, which are not translated into English, may not be considered. For the purpose of interpretation and evaluation of the Application, the English language translation shall prevail.

63 Format and signing of Application

The Applicant shall provide all the information sought under this TENDER. The Authority will evaluate only those Applications that are received in the

required formats and complete in all respects. Incomplete and /or conditional Applications shall be liable to rejection.

The Applicant will upload bid in One Folder in electronic form which shall contain the scanned certified copies of the documents given below and the documents uploaded has to be digitally signed by the bidder. These copies shall be certified by Practicing Notary approved by the Govt. of Maharashtra or Govt. of India with his stamp, clearly stating hisname& registration number, except where original documents are demanded

64 Marking of Applications

The Applicant shall submit the Application in the format specified at Appendix-I, together with the documents, upload in folder as “VENDOR” together with their respective enclosures

Applications submitted by fax, telex, telegram shall not be entertained and shall be rejected outright.

65 Late Applications

Applications received by the Authority after the specified time on the Application Due Date shall not be eligible for consideration and shall be summarily rejected.

66 Confidentiality

Information relating to the examination, clarification, evaluation, and recommendation for the short-listed qualified Applicants shall not be disclosed to any person who is not officially concerned with the process or is not a retained professional advisor advising the Authority in relation to or matters arising out of, or concerning the Bidding Process. The Authority will treat all information, submitted as part of Application, in confidence and will require all those who have access to such material to treat the same in confidence. The Authority may not divulge any such information unless it is directed to do so by any statutory entity that has the power under law to require its disclosure or is to enforce or assert any right or privilege of the statutory entity

and/ or the Authority or as may be required by law or in connection with any legal process.

67 Clarification Of Financial Bids

To assist in the examination, evaluation and comparison of Bids, the Engineer may, at his discretion, ask any bidder for clarification of his Bid, including breakdown of unit rates. The request for clarification and the response shall be in writing or by post/facsimile/e-mail. No Bidder shall contact the Engineer on any matter relating to his bid from the time of the bid opening to the time the contract is awarded. Any effort by the Bidder to influence the Engineer in the Engineer's bid evaluation, bid comparison or contract award decisions may result in the rejection of the Bidder's bid.

68 Inspection of site and sufficiency of tender:

1. The Contractor shall inspect and examine the site and its surrounding and shall satisfy himself before submitting his tender as to the nature of the ground and subsoil (so far as is practicable), the form and nature of the site, the quantities and nature of the work and materials necessary for the completion of the works and means of access to the site, the accommodation he may require and in general shall himself obtain all necessary information as to risk, contingencies and other circumstances which may influence or affect his tender. He shall also take into consideration the hydrological and climatic conditions.
2. The Employer may make available to the Contractor data on hydrological and sub-surface conditions as obtained by or on his behalf from investigations relevant to the works but the Contractor shall be responsible for his own interpretation thereof. The contractor shall engage his investigating agency with prior approval of the Engineer from the approved list of such agencies by MCGM or Govt at his cost initially before commencing actual work and which shall be reimbursed immediately subject to satisfaction of the Engineer for faithful compliance and submission of required data regarding such investigation within specified time.

3. The Contractor shall be deemed to have satisfied himself before tendering as to the correctness and sufficiency of his tender for the works and of the rates and prices quoted in the schedule of works / items / quantities, or in Bill of Quantities, which rates and prices shall, except as otherwise provided cover all his obligations under the Contract and all matters and things necessary for proper completion and maintenance of the works. No extra charges consequent on any misunderstanding.
4. **Not Foreseeable Physical Obstructions or Conditions:** If, however, during the execution of the Works the Contractor encounters physical obstructions or physical conditions, other than climatic conditions on the Site, which obstructions or conditions were, in his opinion, not foreseeable by an experienced contractor, the Contractor shall forthwith give notice thereof to the Engineer. On receipt of such notice, the Engineer shall, if in his opinion such obstructions or conditions could not have been reasonably foreseen by an experienced contractor, after due consultation with the Contractor, determine:
- any extension of time to which the Contractor is entitled and
 - The amount of any costs which may have been incurred by the Contractor by reason of such obstructions or conditions having been encountered, which shall be added to the Contract Price.
 - and shall notify the Contractor accordingly. Such determination shall take account of any instruction which the Engineer may issue to the Contractor in connection therewith, and any proper and reasonable measures acceptable to the Engineer which the Contractor may take in the absence of specific instructions from the Engineer. However such costings shall be got approved by the competent authority as governed vide rules prevailing with authority.
 -
5. **Office for the Engineer (Works costing upto Rs.50 Lakhs)**

The Contractor shall at his own cost and to satisfaction of the Engineer provide a small temporary office, at the work-site which will include tables, chairs and lockers for keeping the records. He shall also make necessary arrangements for drinking water, telephone with a pre-requisite of e-governance and electronic communication. These offices are not to be allowed on public roads without the written instruction of the Engineer. These offices should be preferably located within 50 to 500 m of the worksite. In case the office is more than 500m away from the worksite, the contractor is to provide conveyance for Municipal Staff.

6. **Office for the Engineer (Works costing above Rs.50 lakhs)**

The Contractor shall at his own cost and to satisfaction of the Engineer provide a temporary office at the work-site which will include tables, chairs and lockers for keeping the records. He shall also make necessary arrangements for drinking water, latrines, with doors, windows, locks, bolts and fastenings sufficient for security for the Engineer, and his subordinates, as close to the works from time to time in progress as can be conveniently arranged, and shall at his own cost furnish the office with such chairs, tables, lockers, locks and fastenings as may be required by the Engineer, and no expense of any kind in connection with the erection or upkeep of the offices or fittings shall be borne by the Corporation, but all such work shall be carried out by the Contractor and the expenses thereof defrayed by him. The Contractor shall also make water connections and fit up stand pipe with a bib tap at each office. The latrines and the water connections shall be subject to all the conditions herein elsewhere laid down for temporary water connection and latrines generally with all requisite equipments for e-governance and electronic and digital communication. These offices are not to be allowed on public roads without the written instruction of the Engineer. These offices should be preferably located within 50 to 500 m of the worksite. In case the office is more than 500m away from the worksite, the contractor is to provide conveyance. Also, for staff working beyond working hours the contractor has to provide conveyance.

7. Permission for provision and removal of office on completion of work:

The tenderer shall obtain permission for provision of site office, cement go-down, store, etc. on payment of necessary cost implication. The cement go-down, Watchman cabins, etc. shall be provided as directed and shall be removed by the Tenderers on completion of the work at their cost. It is binding on the Tenderer to fulfil requirements of Environmental Authorities. The location of such office shall be finalized and got approved from the Engineer before erection/commencement work.

- 8. Contractor's office near works:** The Contractor shall have an office near the works at which notice from the Commissioner or the Engineer may be served and shall, between the hours of sunrise and sunset on all working days, have a clerk or some other authorized person always present at such office upon whom such notices may be served and service of any notices left with such clerk or other authorized person or at such office shall be deemed good service upon the Contractor and such offices shall have pre-requisite facilities for e-governance.

69 Official Secrecy:

The Contractor shall of all the persons employed in any works in connection with the contract that the India Official Secrets Act 1923 (XIX of 1923) applies to them and will continue to apply even after execution of the said works and they will not disclose any information regarding this contract to any third party. The contractor shall also bring into notice that, any information found to be leaked out or disclosed the concern person as well as the Contractor will be liable for penal action; further the Corporation will be at liberty to terminate the contract without notice.

70 Subsequent Legislation:

If on the day of submission of bids for the contract, there occur changes to any National or State statute, Ordinance, decree or other law or any regulation or By-laws or any local or other duly constituted authority or the introduction of any such National or State Statute, Ordinance, decree or by which causes additional or reduced cost to the Contractor, such additional or reduced cost

shall, after due consultation with the Contractor, be determined by the concerned Engineering Department of MCGM and shall be added to or deducted from the Contract Price with prior approval of competent authority and the concerned Engineering Department shall notify the Contractor accordingly with a copy to the Employer. MCGM reserve the right to take decision in respect of addition/reduction of costin contract.

71 Patent, Right and Royalties:

The contractor shall save harmless and indemnify the Corporation from and against all claims and proceedings for or on account of infringement of any Patent rights, design trademark or name of other protected rights in respect of any constructional plant, machine work, or material used for or in connection with the Works or any of them and from and against all claims, proceedings, damages, costs, charges and expenses whatsoever in respect thereof or in relation thereto. Except where otherwise specified, the contractor shall pay all tonnage and other royalties, rent and other payments or compensation, if any, for getting stone, sand, gravel, clay or other materials required for the works or any of them.

72 Payments, Tax and Claims:

- **The limit for unforeseen claims**

Under no circumstances whatever the contractor shall be entitled to any compensation from MCGM on any account unless the contractor shall have submitted a claim in writing to the Eng-in-charge within 1 month of the case of such claim occurring.

- **No interest for delayed payments due to disputes, etc:**

It is agreed that the Municipal Corporation of Greater Mumbai or its Engineer or Officer shall not be liable to pay any interest or damage with respect of any moneys or balance which may be in its or its Engineer's or officer's hands owing to any dispute or difference or claim or misunderstanding between the Municipal Corporation of Greater Bombay or its Engineer or Officer on the one hand and the contractor on the other, or with respect to any delay on the part

of the Municipal Corporation of Greater Bombay or its Engineer or Officers in making periodical or final payments or in any other respect whatever.

73 Settlement of Disputes:

- **Termination of contract for death**

If the Contractor is an individual or a proprietary concern and the individual or the proprietor dies and if the Contractor is a partnership concern and one of the legal representative of the individual Contractor or the proprietor of the proprietary concern and in case of partnership, the surviving partners, are capable of carrying out and completing the contract, the Commissioner shall be entitled to cancel the contract as to its uncompleted part without the Corporation being in any way liable to payment of any compensation to the estate of the deceased Contractor and or to the surviving partners of the Contractor's firm on account of the cancellation of the contract. The decision of the Commissioner that the legal representative of the deceased Contractor or surviving partners of the Contractor's firm cannot carry out and complete the contract shall be final and binding on the parties. In the event of such cancellation the Commissioner shall not hold estate of the deceased Contractor and or surviving partners of the Contractor's firm liable in damages for not completing the contract.

- **Settlement of Disputes:**

If any dispute or differences of any kind whatsoever other than those in respect of which, the decision of any person is, by the Contract, expressed to be final and binding) shall arise between the Employer and the Contractor or the Engineer and the Contractor in connection with or arising out of the Contract or carrying out of the Works (Whether during the progress of the Works or after their completion and whether before or after the termination, abandonment or breach of the Contract) it, the aggrieved party may refer such dispute within a period of 7 days to the concerned Addl. Municipal Commissioner who shall constitute a committee comprising of three officers i.e. concerned Deputy Municipal Commissioner or Director (ES&P), Chief Engineer other than the Engineer of the Contract and concerned Chief Accountant. The Committee shall give decision in writing within 60 days.

Appeal on the Order of the Committee may be referred to the Municipal Commissioner within 7 days. Thereafter the Municipal Commissioner shall constitute a Committee comprising of three Addl. Municipal Commissioners including Addl. Municipal Commissioner in charge of Finance Department. The Municipal Commissioner within a period of 90 days after being requested to do so shall give written notice of committee's decision to the Contractor. Save as herein provided such decision in respect of every matter so referred shall be final and binding upon both parties until the completion of the works, and shall forthwith be given effect to by the Contractor who shall proceed with the works with due diligence, whether he requires arbitration as hereinafter provided or not. If the Commissioner has given written notice of the decision to the Contractor and no Claim to arbitration has been communicated within a period of 90 days from receipt of such notice the said decision shall remain final and binding upon the Contractor.

74 Arbitration and Jurisdiction:

If the Commissioner shall fail to give notice of the decision as aforesaid within a period of 90 days after being requested as aforesaid, or if the Contractor be dissatisfied with any such decision, then the Contractor may within 90 days after receiving notice of such decision or within 90 days after the expirations of the first named period of 90 days (as the case may be) require that the matter or matters in dispute be referred to arbitration as hereinafter provided.

- i) In case of contract where the contract price and /or contract value is less than Rs.5,00,00,000/-(Rupees Five Crore Only), any dispute arising out of or in connection with this contract, including any question regarding its existence, validity or termination, shall be referred to a mutually agreed arbitral tribunal in accordance with the Arbitration and Conciliation Act, 1996 (amended upto date). The arbitral tribunal shall consist of a sole arbitrator, as mutually agreed upon by the parties and the said dispute shall be finally resolved by the said arbitral tribunal. The decision of the arbitral tribunal shall be in writing (with reasons) and which will be final and binding upon the parties hereto and the expenses of the arbitration shall be paid as may be determined by the arbitral tribunal. The seat of the arbitration shall be Mumbai. The venue

of arbitration shall be within the limits of Brihan Mumbai. The language of the Arbitration shall be English.

If the parties fails to appoint mutually agreed arbitral tribunal, within the period of 30days from the date of application seeking arbitration in the dispute, the arbitral tribunal shall be appointed by the recognised arbitral institution i.e. Mumbai Centre for International Arbitration (approved by Government of Maharashtra under G.R. no. ARB/Case No.1/2017/D-19 dtd. 28.02.2017 as per the Arbitration Rules of the Mumbai Centre for international Arbitration then in force (MCIA Rules”),

- ii) In case of contract where the contact price and / or contract value is Rs. 5,00,00,000/- (Rupees Five Crore Only) or more, any dispute arising out of or in connection with such a contract, including any question regarding it existence, validity or termination, shall be directly referred to any finally resolved by the recognized arbitral Institution i.e. Mumbai Centre for International Arbitration (approved by Government of Maharashtra under G.R. no. ARB/Case No.1/2017/D-19 dtd. 28.02.2017 as per the Arbitration Rules of the Mumbai Centre for international Arbitration then in force (MCIA Rules”), The arbitral tribunal shall consist of a sole arbitrator. The seat of the arbitration shall be Mumbai. The language of the Arbitration shall be English.

In either case, the law governing this arbitration agreement and the contract shall be Indian Law.

75 Copyright:

The copyright of all drawings and other documents provided by the Contractor under the contract shall remain vested in the Contractor or his sub-contractors as the case may be the employer shall have a license to use such drawings and other documents in connection with the design, construction, operation, maintenance of the works. At any time the Employer shall have further license without additional payment to the Contractor to use any such drawings or documents for the purpose of making any improvement of the works or enlargement or duplication of any part thereof, provided that such improvement, enlargement, or duplication by itself or in conjunction with any

other improvements, enlargements or duplications already made in accordance with the further license does not result in the duplication of the whole works.

76. Receipts to be signed in firm's name by any one of the partners:

Every receipt for money which may become payable or for any security which may become transferable to the Contractor under these present shall, if signed in the partnership name by any one of the partners, be a good and sufficient discharge to the Commissioner and Municipal Corporation in respect of the money or security purporting to be acknowledged thereby, and in the event of death of any of the partners during the pendency of this contract, it is hereby expressly agreed that every receipt by any one of the surviving partners shall, if so signed as aforesaid, be good and sufficient discharge as aforesaid provided that nothing in this clause contained shall be deemed to prejudice or effect any claim which the Commissioner or the Corporation may hereafter have against the legal representatives of any partners so dying or in respect of any breach of any of the conditions thereof, provided also that nothing in this clause contained shall be deemed prejudicial or affect the respective rights or obligations of the Contractors and of the legal representatives of any deceased Contractors interest.

77 Proprietary data

All documents and other information supplied by the Authority or submitted by an Applicant to the Authority shall remain or become the property of the Authority. Applicants are to treat all information as strictly confidential and shall not use it for any purpose other than for preparation and submission of their Application. The Authority will not return any Application or any information provided along therewith.

78 Correspondence with the Applicant

Save and except as provided in this TENDER, the Authority shall not entertain any correspondence with any Applicant in relation to the acceptance or rejection of any Application.

79 Price Variation Clause

The Contractor shall be reimbursed or shall refund to the Corporation as he case may be the variation in the value of the work carried out from time to time, depending on whether the prices of material and labour as a whole rise or fall, and the method adopted for such computations shall be as given below, it being clearly understood that the contractor shall have no claim for being reimbursed on the ground that the price of a particular material or group of materials have risen beyond the limits of the presumptions made in the following paras, however, no price variations shall be made applicable for contracts upto 12 months:

- A) Controlled materials: Price variations shall be permitted in respect of these materials the price level of which is controlled by the Government or its agency. The rate ruling on the date of submission of the tender shall be considered as the basic price of such material for adjustment. Any variation in this rate shall be considered for reimbursement to the contractor or refund to be claimed from the contractor as the case may be. The contractor shall, for the purpose of adjustment submit in original the relevant documents from the suppliers.

- B) Labour and other materials: For the purpose of this contract and for allowing reimbursement of refund on account of variation of prices of (i) labour, and (ii) materials other than materials mentioned in A above, computation will be based on the formula enunciated below which is based on the presumptions that :
 - i) The general price level of labour, rises or falls in proportion to the rise or fall of consumer price index number 9 (general) for working class in Mumbai.
 - ii) The general price level of materials rises or falls in proportion to rise or fall of whole-sale price index as published by 'Economic Adviser to Govt. of India'.

iii) And that the component of labour is to the extent of 30 percent of 88 percent and the component of materials is to the extent of 70 percent of 88 percent of the value of the work carried out. The remaining 12 percent being the presumptive profit of the contractor.

a) Formula for Labour component:

$$VL = \frac{(0.88 R) \times 30 \times (I - IO)}{100 \quad IO}$$

b) Formula for Material component :

$$VM = \frac{(0.88 R \times 70 - C) \times (W - WO)}{100 \quad WO}$$

Where –

VL = Amount of price variation to be reimbursed or claimed as refund on account of general rise or fall of index referred to above.

I = Consumer Price Index number of working class for Mumbai (declared by the Commissioner of Labour and Director of Employment, Mumbai) applicable to the period under reference (base year ending 2004-05 as 100 i.e. new series of indices).

IO = Consumer price index number for working class for Mumbai (declared by the Commissioner of labour and Director of Employment, Mumbai) prevailing, on the day of 28 days prior to the date of submission of the tender.

VM = The amount of price variation to be reimbursed or claimed as refund on account of general rise or fall of wholesale price index for period under reference.

W = Average wholesale price index as published by Economic Adviser to Govt. of India applicable to the period under reference.

WO = Wholesale price index as stated above prevailing on the day of 28 days prior to the date of submission of the tender.

R = Total value of the work done during the period under reference as recorded in the Measurement Book excluding water charges and sewerage charges but including cost of excess in respect of item upto 50 percent

C = Total value of Controlled materials used for the works as recorded in Measurement Book and paid for at original basic rate plus the value of materials used .

- i) The quantity of the Controlled material adopted in working out the value of 'C' shall be inclusive of permitted wastages as / if mentioned in specifications.
- ii) The basic rate for the supply of controlled material shall be inclusive of all the components of cost of materials excluding transport charges incurred for bringing the material from place of delivery to the site.

Computations based on the above formula will be made for the period of each bill separately and reimbursement will be made to (when the result is plus) and refund will claimed from (when the result is minus) the contractor's next bill. The above formulae will be replaced by the formulae in Annexure-I as and when mentioned in special conditions of contract

The operative period of the contract for application of price variation shall mean the period commencing from the date of commencement of work mentioned in the work order and ending on the date when time allowed for the work order and ending on the date when time allowed for the work specified in the contract for work expires, taking into consideration, the extension of time, if any, for completion of the work granted by Engineer under the relevant clause of the conditions of contract in cases other than those where such extension is necessitated on account of default of the contractor.

The decision of the Engineer as regards the operative period of the contract shall be final and binding on the contractors.

- iii) Where there is no supply of controlled items to contractor the component 'C' shall be taken as zero.

C) Adjustment after completion: If the Contractor fails to complete the works within the time for completion adjustment of prices thereafter until the date of

completion of the works shall be made using either the indices or prices relating to the prescribed time for completion, or the current indices or prices whichever is more favorable to the employer, provided that if an extension of time is granted, the above provision shall apply only to adjustments made after the expiry of such extension of time.

- D) Price variation will be calculated similarly and separately for extra items and / or excess quantities and provisional sums calculated under Sub Clause 10 (b)A (i)&(ii) and Sub Clause 10 (b) B(ii) based on the above formula/formulae in Annexure-I as and when mentioned in Special conditions of contract; IO and WO being the indices applicable to the date on which the rates under Sub Clause 10 (a)A (i)&(ii) and Sub Clause 10 (a) B(iii) are fixed. No price variation shall be admissible for FAIR items created during execution.

80. Maximum Price Variation shall be as follows:

Time Period of Project	Maximum limit of Price Variation
Up to 12 months	No variation allowed
Above 12 months to 24 months	5%
Above 24 months	10%

Note: 1) The extension in time period for the projects originally estimated including monsoon results in change of price variation slabs as mentioned above i.e. from first slab to second slab or from second slab to third slab, then the maximum limit of original slab will prevail.

2) Operative period shall mean original or extended time period of contract.

For example:

Extension of Time period	Maximum Price Variation
If original period of 11 months including monsoon extends to 16. The operative period will be 11+5 months.	No variation allowed

<p>If original period of 11 months excluding monsoon extends to 16. The operative period will be 11+5 months.</p>	<p>Maximum 5% variation allowed</p>
--	-------------------------------------

Price Variation during Extended Period of Contract:

- (i) Extension Due To Modification & Extension for delay due to MCGM :
 The price variation for the period of extension granted shall be limited to the amount payable as per the Indices. In case the indices increases or decreases, above/below the indices applicable, to the last month of the original or extended period vide clause 8(l)(a)(i) and (ii) of standard GCC

- (ii) Extension Of Time For Delay Due To Contractor :
 - (a) The price variation for the period of extension granted shall be limited to the amount payable as per the Indices in case the indices increase, above the indices applicable, to the last month of the original completion period or the extended period vide above clause 8(l)(a)(i) and (ii) of standard GCC.

 - (b) The price variation shall be limited to the amount payable as per the indices, in case the indices decrease or fall below the indices applicable, to the last month of original / extended period of completion period vide above clause 8(l)(b) of standard GCC, then lower indices shall be adopted.

- (iii) Extension of Time For Delay due to reasons not attributable to MCGM and Contractor (Reference Cl.8(d) of Standard GCC):
 The price variation for the period of extension granted shall be limited to the amount payable as per the Indices in case the indices increases or decreases, above/below the indices applicable, to the last month of the original period.

81.Payment:

Interim Payment:

- i) Interim bills shall be submitted by the Contractor from time to time (but at an interval of not less than one month) for the works executed. The Engineer shall arrange to have the bills verified by taking or causing to be taken, where necessary, the requisite measurement of work.
- ii) Payment on account for amount admissible shall be made on the Engineer certifying the sum to which the Contractor is considered entitled by way of interim payment for all the work executed, after deducting there from the amount already paid, the security deposit / retention money and such other amounts as may be deductible or recoverable in terms of the contract.
- iii) On request, the contractor will be paid upto 75 percent of the value of the work carried out as an adhoc payment in the first week of next month after deducting there from recoveries on account of advances, interest, retention money, income tax etc. The balance payment due will be paid thereafter.
- iv) No interim payment will be admitted until such time the Contractor have fully complied with the requirement of the Condition no.8 (g) and 8 (h) concerning submission and approval of Network Schedule for the works, as detailed in Condition 8 (h). A fixed sum shall be held in abeyance at the time of next interim payment for non-attainment of each milestone in the network and shall be released only on attainment of the said milestone.
- iv) An interim certificate given relating to work done or material delivered may be modified or corrected by a subsequent interim certificate or by the final certificate. No certificate of the Engineer supporting an interim payment shall of itself be conclusive evidence that any work or materials to which it relates is / are in accordance with the contract.

82 Banning/De-Registration of Agencies of Construction works in MCGM

- The regulations regarding Demotion/ Suspension Banning for specific period or permanently / De-Registration shall be governed as per the respective condition in Contractor Registration Rules of MCGM.

83. JOINT VENTURE

Not Applicable.

84. Compensation for delay:

If the Contractor fails to complete the works and clear the site on or before the Contract or extended date(s) / period(s) of completion, he shall, without prejudice to any other right or remedy of Municipal Corporation on account of such breach, pay as agreed compensation, amount calculated as stipulated below (or such smaller amount as may be fixed by the Engineer) on the contract value of the whole work or on the contract value of the time or group of items of work for which separate period of completion are given in the contract and of which completion is delayed for every week that the whole of the work of item or group of items of work concerned remains uncompleted, even though the contract as a whole be completed by the contract or the extended date of completion. For this purpose the term 'Contract Value' shall be the value of the work at Contract Rates as ordered including the value of all deviations ordered:

- Completion period for projects (originally stipulated or as extended) not exceeding 6 months: **to the extent of maximum 1 percent per week.**
- Completion period for projects (originally stipulated or as extended) exceeding 6 months and not exceeding 2 years: **to the extent of maximum ½ percent per week.**
- Completion period for projects (originally stipulated or as extended) exceeding 2 years : **to the extent of maximum ¼ percent per week.**

When the delay is not a full week or in multiple of a week but involves a fraction of a week the compensation payable for that fraction shall be proportional to the number of days involved.

Provided always that the total amount of compensation for delay to be paid this condition shall not exceed the undernoted percentage of the Contract Value of the item or group of items of work for which a separate period of completion is given.

- i) Completion period (as originally stipulated or as extended) not exceeding 6 months: **10 percent.**
- ii) Completion period (as originally stipulated or as extended) exceeding 6 months and not exceeding 2 years: **7½ percent.**

iii) Completion period (as originally stipulated or as extended) exceeding 2 years :**5 percent.**

The amount of compensation may be adjusted set off against any sum payable to the contractor under this or any other contract with the Municipal Corporation.

85. Action And Compensation Payable In Case Of Bad Work And Not Done As Per Specifications

All works under or in course of execution or executed in pursuance of the contract, shall at all times be open and accessible to the inspection and supervision of the Engineer-in-charge, his authorized subordinates in charge of the work and all the superior officers, officer of the Vigilance Department of the MCGM or any organization engaged by the MCGM for Quality Assurance and the contractor shall, at all times, during the usual working hours and at all other times at which reasonable notice of the visit of such officers has been given to the contractor, either himself be present to receive orders and instructions or have a responsible agent duly accredited in writing, present for that purpose. Orders given to the Contractor's agent shall be considered to have the same force as if they had been given to the contractor himself.

If it shall appear to the Engineer-in-charge or his authorized subordinates in-charge of the work or to the officer of Vigilance Department, that any work has been executed with unsound, imperfect or unskilful workmanship or with materials of any inferior description, or that any materials or articles provided by him for the execution of the work are unsound or of a quality inferior to that contracted for or otherwise not in accordance with the contract, the contractor shall, on demand in writing which shall be made within twelve months of the completion of the work from the Engineer-in-Charge specifying the work, materials or articles complained of notwithstanding that the same may have been passed, certified and paid for forthwith rectify, or remove and reconstruct the work so specified in whole or in part, as the case may require or as the case may be, remove the materials or articles so specified and provide other proper and suitable materials or articles at his own charge and cost. In the event of the failing to do so within a period specified by the Engineer-in-Charge in his demand aforesaid, then the contractor shall be liable to pay compensation at the same rate as under

clause 8.e. of the general condition of contract in section 9 of tender document (for Compensation for delay) for this default. In such case the Engineer-in Charge may not accept the item of work at the rates applicable under the contract but may accept such items at reduced rates as the Engineer in charge may consider reasonable during the preparation of on account bills or final bill if the item is so acceptable without detriment to the safety and utility of the item and the structure or he may reject the work outright without any payment and/or get it and other connected and incidental items rectified, or removed and re-executed at the risk and cost of the contractor. Decision of the Engineer-in-Charge to be conveyed in writing in respect of the same will be final and binding on the contractor.

If the penalization amount exceeds maximum limit with respect to Clause 8.e of Standard General Conditions of Contract, then a show cause notice shall necessarily be issued to the contract as to why the contract should not be terminated.

The above clause is summarized to make it easy to understand as follows:

- 1.** *The Engineer-in-charge shall issue notice to the contractor for rectifying the defects or redoing of the work if necessary, within specific time to achieve the desired quality and quantity of the work and this should be governed by clause 8.f and 9.b of Standard General Conditions of Contract.*
- 2.** *If the contractor fails to comply the same, only then, the contractor shall be liable to pay compensation at the same rate as under clause 8.e of the Standard General Condition of Contract (for Compensation for delay) for this default.*
- 3.** *If the penalization amount exceeds the maximum limit, then the contractor will be liable for being banned/ deregistered from business dealings with MCGM and this shall be governed by relative provision in Registration Rules of MCGM and Standard General Conditions of Contract.*
- 4.** *This penalization shall be levied only on account of delay in work, unsound, imperfect or unskilful workmanship or with materials of any inferior*

description, or that any materials or articles provided by him for the execution of the work are unsound or of quality inferior to that contracted for or otherwise not in accordance with the contract.

86. Contractors remain liable to pay compensation:

In any case in which any of the powers conferred upon the Engineer In-charge by the **relevant clauses** in documents that form a part of contract as exercised or is exercisable in the event of any future case of default by the Contractor, he is declared liable to pay compensation amounting to the whole of his security deposit. The liability of the Contractor for past and future compensation shall remain unaffected.

In the event of the Executive Engineer taking action against these **relevant clauses**, he may, if he so desires, take possession of all or any tools and plant, materials and stores in or upon the work of site thereof or belonging to the Contractor or procured by him and intended to be used for the execution of the work or any part thereof paying or allowing for the same in account at the contract rates, or in the case of contract rates not being applicable at current market rates to be certified by the Executive Engineer, may after giving notice in writing to the Contractor or his staff of the work or other authorized agent require him to remove such tools and plants, materials or stores from the premises within a time to be specified in such notice and in the event of the Contractor failing to comply with any such requisition, the Executive Engineer may remove them at the contractors expense or sell them by auction or private sell on account of the Contractor at his risk in all respects and certificate of the Executive Engineer as to the expense of any such removal and the amount of the proceeds an expense of any such sell be final and conclusive against the Contractor.

87. No Claim to Any Payment or Compensation or Alteration in or Restriction of Work

(a) If at any time after the execution of contract documents, the Engineer shall for any reason whatsoever, desires that the whole or any part of the works specified in the Tender should be suspended for any period or that the whole or part of the work should not be carried out, at all, he shall give to the Contractor a Notice in writing of such desire and

upon the receipt of such notice, the Contractor shall forthwith suspend or stop the work wholly or in part as required after having due regard to the appropriate stage at which the work should be stopped or suspended so as not to cause any damage or injury the work already done or endanger the safety thereof, provided that the decision of the Engineer as to the stage at which the work or any part of it could be or could have been safely stopped or suspended shall be final and conclusive against the contractor.

The Contractor shall have no claim to any payment or compensation whatsoever by reason of or in pursuance of any notice as aforesaid, on account of any suspension, stoppage or curtailment except to the extent specified hereinafter.

- (b) Where the total suspension of Work Order as aforesaid continued for a continuous period exceeding 90 days the contractor shall be at liberty to withdraw from the contractual obligations under the contract so far as it pertains to the unexecuted part of the work by giving 10 days prior notice in writing to the Engineer within 30 days of the expiry of the said period of 90 days, of such intention and requiring the Engineering to record the final measurement of the work already done and to pay final bill. Upon giving such Notice, the Contractor shall be deemed to have been discharged from his obligations to complete the remaining unexecuted work under his contract. On receipt of such notice the Engineer shall proceed to complete the measurement and make such payment as may be finally due to the contractor within a period of 90 days from the receipt of such Notice in respect of the work already done by the contractor. Such payment shall not in any manner prejudice the right of the contractor to any further compensation under the remaining provisions of this clause.
- (c) Where the Engineer required to Contractor to suspend the work for a period in excess of 30 days at any time or 60 days in the aggregate, the Contractor shall be entitled to apply to the Engineer within 30 days of the resumption of the work after such suspension for payment of compensation to the extent of pecuniary loss suffered by him in respect of working machinery remained ideal on the site of on the account of his having an to pay the salary of wages and labour

engaged by him during the said period of suspension provided always that the contractor shall not be entitled to any claim in respect of any such working machinery, salary or wages for the first 30 days whether consecutive or in the aggregate or such suspension or in respect of any such suspension whatsoever occasion by unsatisfactory work or any other default on his part, the decision of the Engineer in this regard shall be final and conclusive against the contractor.

88. Contractor to supply plant, ladder, scaffolding, etc and is liable for damages arising from non provision of lights, fencing, etc.

The Contractor shall supply at his own cost all material, plant, tools, appliances, implements, ladders, cordage, tackle scaffolding and temporary works requisite or proper for the proper execution of the work, whether, in the original altered or substituted form and whether included in the specification of other documents forming part of the contract or referred to in these conditions or not and which may be necessary for the purpose of satisfying or complying with the requirements of the Eng-In-Charge as to any matter as to which under these conditions is entitled to be satisfied, or which is entitled to require together with the carriage therefore to and from the work.

The Contractor shall also supply without charge, the requisite number of person with the means and materials necessary for the purpose of setting out works and counting, weighing and assisting in the measurements of examination at any time and from time to time of the work or materials, failing which the same may be provided by the Engineer In-charge at the expense of the contractor and the expenses may be deducted from any money due to the contractor under the contract or from his security deposit or the proceeds of sale thereof, or offers sufficient portion thereof.

The contractor shall provide all necessary fencing and lights required to protect the public from accident and shall also be bound to bear the expenses of defence of every suit, action or other legal proceedings, that may be brought by any person for injury sustained owing to neglect of the above precautions and to pay any damages and cost which may be awarded in any such suit action or proceedings to any such person or which may with the

consent of the contractor be paid for compromising any claim by any such person.

89. Prevention of Fire:

The contractor shall not set fire to any standing jungle, trees, brushwood or grass without a written permit from the Engineer In-charge. When such permit is given, and also in all cases when destroying cut or dug up trees brushwood, grass, etc., by fire, the contractor shall take necessary measure to prevent such fire spreading to or otherwise damaging surrounding property. The Contractor shall make his own arrangements for drinking water for the labour employed by him.

90. Compensation for all damages done intentionally or unintentionally by contractor's labour whether in or beyond the limits of MCGM property including any damage caused by spreading the fire shall be estimated by the Engineer In-charge or such other officer as he may appoint and the estimate of the Engineer in-charge to the decision of the Dy. Chief Engineer on appeal shall be final and the contractor shall be bound to pay the amount of the assessed compensation on demand failing which the same will be recovered from the Contractor as damages or deducted by the Engineer In-charge from any sums that may be due or become due from MCGM to contractor under this Contract or otherwise. Contractor shall bear the expenses of defending any action or other legal proceedings that may be brought to prevent the spread of fire and he shall pay any damages and costs that may be awarded by the Court in consequence.

91. In the case of Tender by partners, any change in the constitution of the firm shall be forthwith, notified by the contractor through the Engineer In-charge for his information.

92. Action where no specifications:

In the case of any class of work for which there is no such specifications, such works shall be carried out in accordance with the specifications and in the event of there being no such specifications, then in such case, the work shall be carried out in all respects in accordance with all instructions and requirements of the Engineer In-charge.

93. Safety and medical help:

- (i) The Contractor shall be responsible for and shall pay the expenses of providing medical help to any workmen who may suffer a bodily injury as a result of an accident. If such expenses are incurred by MCGM, the same shall be recoverable from the contractor forthwith and be included without prejudice to any other remedy of MCGM from any amount due or that may become due to the Contractor.
- (ii) The contractor shall provide necessary personal safety equipment and first-aid box for the use of persons employed on the site and shall maintain the same in condition suitable for immediate use at any time.
- (iii) The workers shall be required to use the safety equipments so provided by the contractor and the contractor shall take adequate steps to ensure the proper use of equipments by those concerned.
- (iv) When the work is carried on in proximity to any place where there is risk or drawing all necessary equipments shall be provided and kept ready for use and all necessary steps shall be taken for the prompt rescue of any person in danger.

94. No compensation shall be allowed for any delay caused in the starting of the work on account of acquisition of land or in the case of clearance of works, on account of ant delay in according to sanction of estimates.

95. Anti-malaria and other health measures:

Anti-Malaria and other health measures shall be taken as directed by the Executive Health Officer of MCGM. Contractor shall see that mosquitogenic conditions are created so as to keep vector population to minimum level. Contractor shall carry out anti-malaria measures in the area as per the guidelines issued by the Executive Health Officer of MCGM from time to time.

In case of default, in carrying out prescribed anti-malaria measures resulting in increase in malaria incidence, contractor shall be liable to pay MCGM on anti-malaria measures to control the situation in addition to fine.

96 As per circular no. CH.E./ BM/15600 /HIC dtd 09.01.2019 the following amendments / corrections is proposed in Section-9 Clause no. 83 joint venture, last paragraph regarding Financial Eligibility Criteria

As per SBD	Proposed Amendments
The contractual payments received by the JV firm or the arithmetic sum of contractual payments received by all the members of JV firm in any one of the previous three financial years shall be at least 100% of the estimated value of the work as mentioned in the tender”	“The average annual contractual payments received by the JV firm or the arithmetic sum of average annual contractual payments received by all the members of JV firm, in proportion to their share in JV, in last three financial years shall be at least 30% of the estimated value of the work as mentioned in the tender.

97 As per circular no. DMC/CPD/3217 dtd. 02.03.2019 the following point is added:

Jurisdiction of courts

- In case of any claim, disputes or differences arising in respect of the contract, the causes of action thereat shall be deemed to have arisen in Mumbai and all legal proceedings in respect of any such claim, disputes or differences shall be instituted in a Competent Court in the City of Mumbai only.
- M.C.G.M. has formed 'Procurement Redressal Committee' under the chairmanship of retired High Court Justice MCGM for the Redressal of grievances of Bidders/prospective bidders/ related to procurement. The bidders/complainants can approach 'Procurement Redressal Committee' for Redressal of their grievances by paying fees of Rs.25000/-. The details of 'Procurement Redressal Committee' are given in Annexure-E.
- However, Municipal Commissioner has right to reject the request of bidder to allow to approach for Procurement Redressal Committee.

MUNICIPAL CORPORATION OF GREATER MUMBAI

CIRCULAR

U/No.MGC/F/6342 dated 5.5.2018

Sub.: Revised guidelines regarding barricades being used during the execution of various infrastructure development projects by MCGM in Mumbai.

Various infrastructure development projects are being executed by MCGM for the betterment of citizens of Mumbai. During the course of execution of the

projects, it is necessary to provide strong and secured barricading as a safety measure to avoid any mishaps as well as to avoid nuisance to vehicular and pedestrian traffic. Nowadays, the following types of barricades are being used exclusively in MCGM as per the convenience of various departments at different sites.

1. Water/sand fillable PVC Metro barricades.
2. RW 7.45 (G.I. sheets of 22 gauge fixed on 3 inch dia. Wooden bullies buried in existing road sufficiently)
3. RW 7.36 (G.I. sheets of 22 gauge fixed on MS Angle post buried in half the depth in drums of 20 litres capacity in 1:3:6 concrete)
4. Structural steel barricade for major trenches having depth more than 2.00 meters.

Thus from the above, it can be seen that there is no uniformity in provision of barricades as they are of different size and shape. Further it is also observed that the continuity is not maintained in providing the barricading keeping gaps in between thus endangering the safety of vehicular as well as pedestrian traffic. Also the barricades are not being cleaned, thus further adding to shabbiness. Further Mumbai being the financial capital of India, people from all over the world visit the city daily and to maintain good image of city the following decisions are taken.

- A. Only two type of barricades having department wise colour coding are proposed to be used depending upon the nature of work i.e. Minor and Major.
 - i. **Minor works:** Barricading made out of 1.5 mm thick MS plate fixed on M.S. angle post/ frame of 65 mm X 65 mm X 6 mm having height of 1.5 m supported on as shown in Annex-I.
 - ii. **Major works:** Structural steel barricade made out of 1.50 mm thick M.S. Plate ISMB 250, ISLC 250X50mm and ISA 50mmX50mmX6 mm having of size 2.5 m X 2 m as shown in Annex-II.
- B. The department wise colour coding for the barricading shall be as under:-
 - i. H.E. & W.S.P. department – **Blue**
 - ii. Roads, Traffic, Bridges and Coastal Roads department– **Yellow**
 - iii. S.P. & S.O department – **Green**
 - iv. S.W.D., Building Maintenance department &for ward works –**Red**

- C. The basic principle behind installing secured and continuous barricading is to ensure the safety of vehicular as well as pedestrian traffic and residents in the nearby vicinity of the project. Due to non-installation of appropriate barricades on sites if any mishap occurs leading to injury or loss of life, then the contractor and contractor's Engineer in-charge will be liable for the consequent action.
- D. During the course of execution of project, if it is noticed that the contractor has not provided barricading then a penalty of Rs.1000/- per meter per day will be imposed upon the contractor and will be deducted from the due Bill. This penalty shall be a part of penalty as per tender condition.
- E. Details of the work shall be prominently displayed on the central panel of the barricades along-with the Social Slogans as given in Annexure III and the Cycle of the same shall be maintained.
- F. The contractor shall provide and install the barricading alongwith the slogans printed as per the Annexure III, at his own cost and no payment will be made for this, however the contractor shall quote the bid accordingly by considering the cost of barricading.

The condition shall be included in the tender as given below.

“Barricading shall be provided free of cost as per Circular vide U/No.MGC/F/6342 dated 5.5.2018 and as per Annexure I, II and III of Standard drawings and specifications with slogans and department wise colour codes.” The copy of circular will be attached to the tender as a part of tender document.

This circular will be applicable for the new tenders proposed to be invited from 01.05.2018 and also the corrigendum shall be attached to tenders which are uploaded. However, for the projects wherein the tenders are already invited, the barricading shall be provided strictly as per tender condition. All the details (Annexure I, II & III of Standard drawings and specifications with slogans and department wise colour codes, sketches and department wise colour coding) are uploaded on MCGM portal.

This circular shall come in force with immediate effect.

sd/- 20.4.2018
(Shri V.P .Chithore)

Dir.(ES&P)

sd/- 21.4.2018
(Shri Vijay Singhal)

A.M.C.(E.S.)

sd/- 20.4.2018
(Shri R. B. Bambale)

D.M.C.(S.E.)

sd/- 21.4.2018
(Dr.Shri Sanjay Mukherjee)

A.M.C.(P.)

sd/- 5.5.2018
(ShriAjoy Mehta)

M. C.

sd/-16.5.2018
(Shri P. R. Kadam)

D.M.C.(S.E.)

ANNEXURE I

A) Minor work

Providing, fabricating and installing the barricading made out of 1.5 m high M.S. Angle post of 65 mm X 65 mm X 6 mm with 1.5 mm thick M.S. Sheet of size 1.55 m X 1.2 m welded to the M.S. angle post/ frames and fixed to 75mm X 75mm X 6 mm angle base as shown in sketch for minor works , displaying of the social slogan as per the Annex - III, daily cleaning of the same to get better appearance and interlocking arrangement to ensure continuity in provision and to avoid gap in between etc complete and as directed by Engineer in-charge.

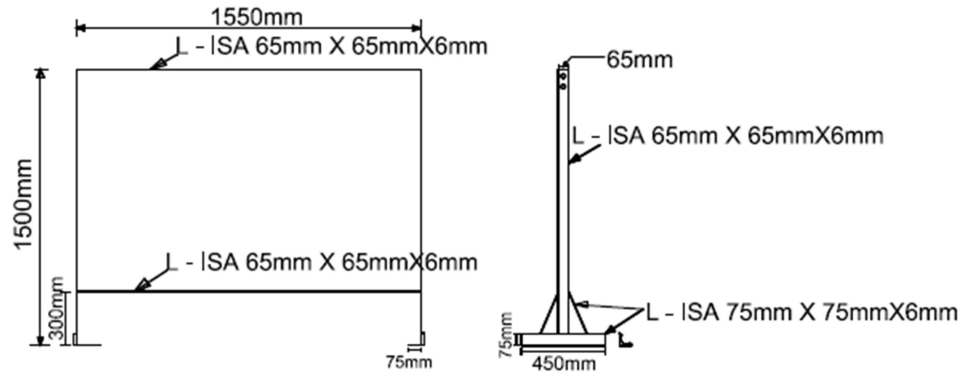

ANNEXURE II

B) Major works:

Providing, fabricating and installing the structural steel barricading made out of 1.5 mm thick M.S. plate of size 2500 mm X 2000 mm, ISMC 250 X 50 channels, M.S. Angles ISA 50 X 50 X 6mm and ISMB 250 as per IS 1161-1 RHS/SHS rolled angle plates of TATA Steel, Lloyd Steel, SAIL, ESSAR steel approved in straight profile of all sizes, shapes and for all works including stiffeners, bolts and nuts, filet / butt welding, splicing, machine grinding, of all member joints wherever required to give neat appearance, and daily cleaning the barricading along with displaying of the Depthwise slogans as given in Annexure -III etc with interlocking arrangement to avoid gap in between and as directed by Engineer in-charge.

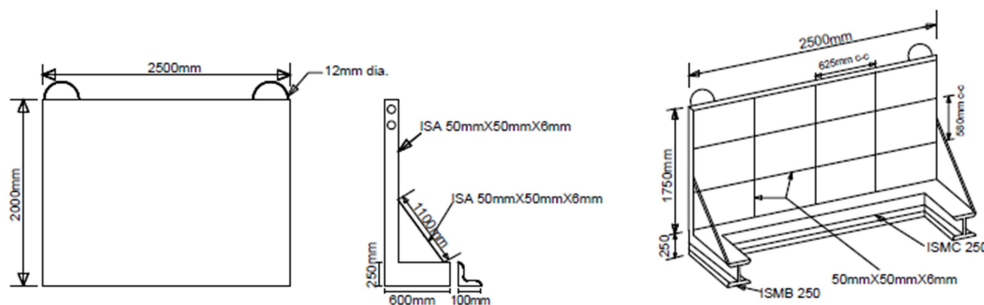

ANNEXURE III

1) HYDRAULIC ENGINEER'S DEPARTMENT/ WATER SUPPLY PROJECTS

- i) Inconvenience regretted
- ii) Ensuring Mumbai's water supply
- iii) Save water Save life

2) ROAD, TRAFFIC / BRIDGES DEPARTMENT

- i) Inconvenience regretted
- ii) Working towards a better tomorrow
- iii) My Mumbai, Green Mumbai

3) SEWERAGE PROJECTS DEPARTMENT/ SEWERAGE OPERATIONS

DEPARTMENT

- i) Inconvenience regretted
- ii) Reduce Reuse Recycle
- iii) Clean Mumbai , healthy Mumbai

4) STORM WATER DRAIN DEPARTMENT/ WARD WORKS

- i) Inconvenience regretted
- ii) Working towards a better tomorrow
- iii) Swatch Bharat

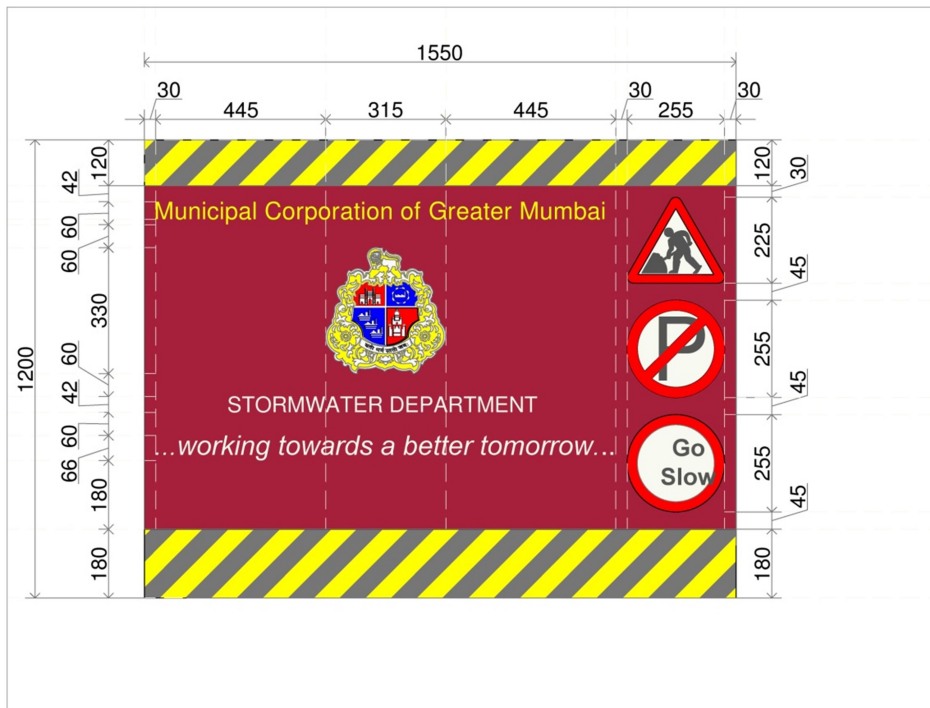



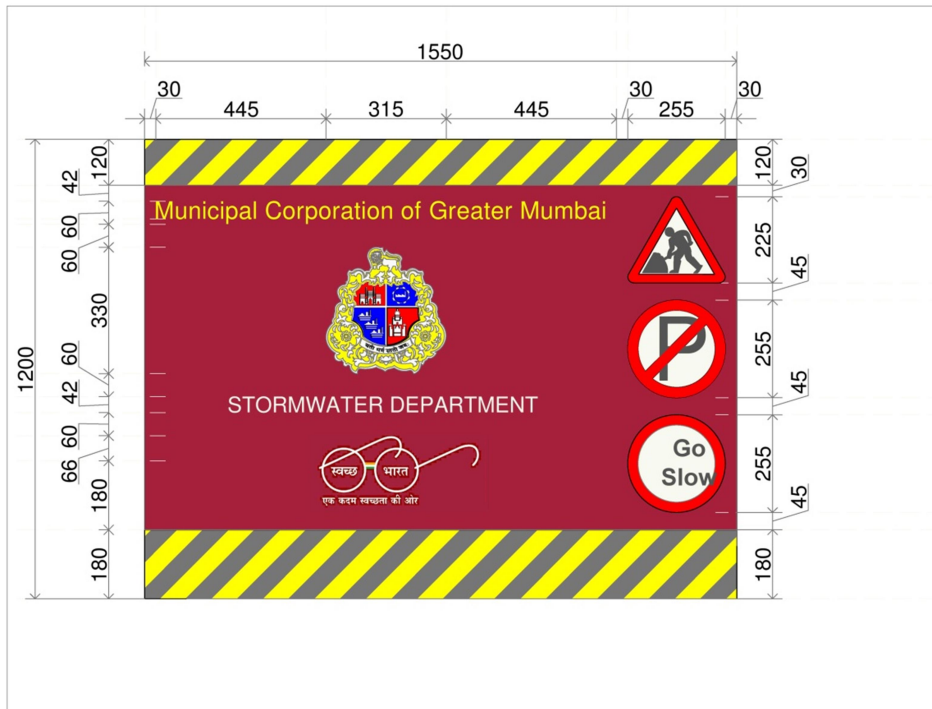



बृहन्मुंबई महानगरपालिका

परिपत्रक

प्र.ले./वित्त/प्रकल्प/ 25 दि. 12/09/2022

विषय: महानगरपालिकेद्वारे हाती घेण्यात येणारी विविध प्रकल्प कामे तसेच प्राप्त करण्यात येणा-या वस्तु व सेवा इत्यादीबाबतच्या ई-निविदा/निविदा/दरपत्रक यामध्ये वस्तु व सेवा कराच्या अनुषंगाने अंतभूत करावयाच्या अटीबाबत.

संदर्भ: १) प्र.ले./वित्त/प्रकल्प/शहर/३३ दि.०४.०३.२०१७

२) प्र.ले./वित्त/प्रकल्प/शहर/१२०अ दि.०८.०५.२०१७

३) प्र.ले./वित्त/प्रकल्प/शहर/८ दि.१४.०७.२०१७

४) प्र.ले./वित्त/प्रकल्प/शहर/२८ दि.१०.११.२०१७

५) Press Release: 47th Meeting of the GST Council, Chandigarh
28th and 29th June, 2022.

बृहन्मुंबई महानगरपालिकेद्वारे हाती घेण्यात येणाऱ्या विविध प्रकल्प कामे तसेच प्राप्त करण्यात येणा-या वस्तु व सेवा इत्यादीबाबतच्या ई-निविदा/निविदा/दरपत्रक यामध्ये वस्तु व सेवा कराच्या अनुषंगाने अंतभूत करावयाच्या अटीबाबत संदर्भित परिपत्रकान्वये सूचना प्रसृत केल्या आहेत.

वस्तु व सेवाकरांच्या दरात फेरबदल करण्याबाबत शासन विचाराधीन असल्याने महानगरपालिकेतील विविध कामांच्या निविदांबाबत संभाव्य निविदाकार महापालिकेस निवेदन सादर करत आहेत. अतएव, महानगरपालिकेद्वारे हाती घेण्यात येणारी विविध प्रकल्प कामे तसेच प्राप्त करण्यात येणा-या वस्तु व सेवा इत्यादीबाबतच्या ई-निविदा/निविदा/दरपत्रक यामध्ये संदर्भित क्र.५ अन्वये दिलेल्या वस्तु व सेवा कराच्या अनुषंगाने अंतभूत करावयाच्या अटीमध्ये खालीलप्रमाणे बदल करण्यात येत आहे.

विद्यमान अट	सुधारित अट
<p>“GST and other state levies/cess which are not subsumed under GST will be applicable. The tenderer shall quote inclusive of all taxes. It is clearly understood that BMC will not bear any additional liability towards payment of any Taxes & Duties.</p> <p>Wherever the services to be provided by the Tenderers, falls under Reverse Charge Mechanism, the Price quoted shall be exclusive of GST, but inclusive of Taxes/Duties/Cess other than GST, if any.</p> <p>Rates accepted by BMC shall hold good till completion of work and no additional individual claim shall be admissible on account of fluctuations in market rates; increase in taxes/any other levies/tolls etc. except that payment/recovery for overall market situation shall be made as per Price variation.</p>	<p>“GST and other state levies/cess which are not subsumed under GST will be applicable. The tenderer shall quote inclusive of all taxes <u>applicable at the time of bid submission</u>. It is clearly understood that BMC will not bear any additional liability towards payment of any Taxes & Duties.</p> <p>Wherever the services to be provided by the Tenderers, falls under Reverse Charge Mechanism, the Price quoted shall be exclusive of GST, but inclusive of Taxes/Duties/Cess other than GST, if any.</p> <p>Rates accepted by BMC shall hold good till completion of work and no additional individual claim shall be admissible on account of fluctuations in market rates; increase in taxes/any other levies / tolls etc. except that payment/recovery for overall market situation shall be made as per Price variation and if there is any subsequent change (after submission of bid) in rate of GST applicable on the work/services to be executed as per tender, i.e. any increase will be reimbursed by BMC whereas any reduction in the rate of GST shall be passed on to BMC as per the provisions of the GST Act.</p>

उपरोक्त सुधारित अट ही ज्या कामांच्या ई-निविदा/निविदा/दरपत्रक दस्तऐवज यामध्ये समाविष्ट केलेली असेल फक्त त्याच कामांकरिता लागू असेल.

अतएव, प्राप्त होणारे देकार प्रचलित वस्तु व सेवा करांच्या दरानुसार प्राप्त होणार असल्याने, सध्या ज्या ई-निविदा/निविदा/दरपत्रक मागविलेल्या आहेत अशा निविदांमध्ये

नियत दिनांकापूर्वी शुद्धीपत्रकाद्वारे उपरोक्त सुधारीत अट समाविष्ट करण्याबाबत तसेच यापुढे मागविण्यात येणाऱ्या ई-निविदा/निविदा/दरपत्रक यांमध्ये उपरोक्त सुधारीत अट समाविष्ट करण्याची संबंधित खातेप्रमुख यांनी दक्षता घ्यावी. तसेच वस्तु व सेवा कराच्या दरातील बदल हा शासन निर्णयामधील दिनांकापासून प्रभाव्य राहिल.

सर्व खातेप्रमुख, रूग्णालयांचे अधिष्ठाता, सहायक आयुक्त, यांनी उपरोक्त सुचनांचे काटेकोरपणे अनुपालन करावे.

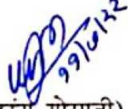

(पांडुरंग गोसावी)

प्रमुख लेखापाल (पा.पु.म.नि.)

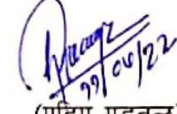

(प्रदिप पडवळ)

प्रमुख लेखापाल (वित्त) प्र.

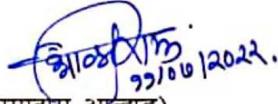

(रामदास अक्हाड)

उप आयुक्त (वित्त)



(पी. वेण्कटेश)

अतिरिक्त आयुक्त (प्रकल्प)

SECTION 10

**SPECIFICATIONS
& SELECTION OF MATERIAL**

SPECIFICATIONS & SELECTION OF MATERIAL

The tender is prepared on the basis of Unified Schedule of Rates and specifications 2018. The specifications of the items of USOR are available on MCGM portal <http://portal.mcg.gov.in> under the Tender tab. Hence the deserving contractor shall either download the same from MCGM portal or the same may be collected in the soft copy format at the time of purchasing the tender from this office.

SELECTION OF MATERIAL

1. All materials brought on the site of work and meant to be used in the same, shall be the best of their respective kinds and to the approval of the Engineer. The Engineer or his representative will accept that the materials are really the best of their kinds, when it is proved beyond doubt that no better materials of the particular kind in question are available in the market.
2. The contractor shall obtain the approval of the Engineer of samples of all materials to be used in the works and shall deposit these samples with him before placing an order for the materials with the suppliers. The materials brought on the works shall conform in every respect to their approved samples. Fresh samples shall be deposited with the Engineer when-ever the type or source of any material changes.
3. The contractor shall check each fresh consignment of materials as it is brought to the site of works to see that they conform in all respects to the Specifications of the samples approved by the Engineer, or both.
4. The Engineer will have the option to have any of the materials tested to find out whether they are in accordance with the Specifications and the Contractor will bear all expenses for such testing. All B bills, vouchers and test certificates, which in the opinion of the Engineer or his representative are necessary to convince him as to the quality of the materials or their suitability shall be produced for his inspection when required.
5. Any materials that have not been found to conform to the specifications will be rejected forthwith and shall be removed from the site by the contractor at his own cost within 24 hours.
6. The Engineer shall have power to cause the Contractors to purchase and use such materials from any particular source, as may in his opinion be necessary for the proper execution of the work.
7. Notwithstanding the source, the sand shall be washed using sand washing machine before use.

List of Approved Building Materials

MUNICIPAL CORPORATION OF GREATER MUMBAI

No. Ch.E./BM/07591/II Date 05.07.2022

Sub.:- List of Approved Building Materials updated up to 30.06.2022.

Following brands of building materials have been approved by Ch.E.(B.M.)/Director (E. S.& P.). The brands of the building materials approved and mentioned in the list with the validity given below shall be used. For the materials other than mentioned in the list brands, only ISI marks materials shall be allowed to be used with prior written permission of the engineer, for individual work. The contractors shall distinctly understand that it will not be their prerogative to insist for use of particular make/brand from following list and final selection will have to be done with approval of engineer. The following list of approved building materials may vary and some new category/brand may be added or existing ones may be deleted. The contractor shall use the brand as directed by the engineer.

Sr. No	Category	Product	Brand Name if any	Manufacturer's Name & Correspondence address	Contact Details	Validity
1.	Cement	OPC 53 Grade & PPC	"SANGHI"	M/s. Sanghi Cement Limited, Krishna Commercial Centre, 11, B-Wing, 6-Udyog Nagar, S.V. Road, Near Kamath Club, Goregaon (West), Mumbai- 400 062	(022)-28713120 (0261)-2331019	27.07.2023
2.	Cement	OPC 53 Grade PPC	"HATHI"	M/s. Saurashtra Cement Limited, Gala No. A-1, Ground Floor, Udhog Sadan No. 3, MIDC, Central Road, Andheri (East), Mumbai- 400 093	(022)-32955567 / 32955557	24.09.2023
3.	Cement	OPC 43, 53 Grade & PPC	"PERFORMATE, OPTIMATE & DURAMATE"	M/s. Kalburgi Cement Private Limited. 8-2-626, Reliance Majestic, Road No. 10, Banjara Hills, Hyderabad-500034	(022)-40831234	18.03.2024
4.	Cement	OPC 53 Grade & PSC	"PSC & CONCREEL HD"	M/s. JSW Cement Limited, JSW Centre, Bandra Kurla Complex, Bandra (E), Mumbai-400051	Mob.:-9820234395	03.03.2024
5.		OPC 53 & PPC	SHREE CEMENT - ROOFON & JUNGROD HAK	M/s. Shree Cement Ltd, One BKC Building, 1110 A, 11TH Floor, C Wing, Plot no. C-66, G Block, Bandra Kurla Complex, Bandra (East), Mumbai- 400 051	Mob.:-9819623490	22.03.2025
6.	GGBS	Ground Granulated Blast Furnace Slag	JSW	M/s. JSW Cement Limited, JSW Centre, Bandra Kurla Complex, Bandra (E), Mumbai-400051	Mob.:-9819990801	03.03.2024

7.	White Cement	White Cement, Putty & Others	J K MAXX	M/s. J. K. White Cement Works 4TH Floor, Krsna Chambers, Plot no. 11, Galaxy Garden, North Main Road, Koragaon Park, Pune-411001		22.03.2025
8.	Reinforcement Protection coating	Epoxy Reinforcement Bars	“EPOXY SHIELD”	M/s. Hariom Ingots & Power Pvt. Ltd., Plot 59-60, Light Industrial Area, Bhilai, Chhattisgarh-490 026.	Mob.:- 78840553 00	01.02.2023
9.	Reinforcement Protection coating	Epoxy Reinforcement Bars		M/s. Eurocoustic Products Ltd. FBEC Divn, PSL Campus, Kachigam (Via Vapi-Guj), Daman, (U.T.)-396210	022- 66447777 / 66447787	09.11.2023
10.	Reinforcement Bars	TMT bars of Grade (Fe415, Fe500, Fe500D)	“SURYA TMX”	M/s Surya Ferrous Alloys Private Ltd. 117, 1 ST Floor, Sky Lark Building, Sector No. 11, Plot No. 63, C.B.D. Belapur, Navi Mumbai- 400614	(022)- 27573081 / 7480 / 7420	08.11.2023
11.	Reinforcement Bars	TMT bars of Grade (Fe415, to Fe550D)	“SUN TMX QST” & “MORIYA”	M/s. Jaideep Metallics & Alloys Pvt. Ltd., Gut No. 73, 74, 76, 78, 79, 80, 179, 180, Village Lakhmapur, Bhiwandi Wada Road, Taluka Wada, Thane-421303.	(022)- 42032003 FAX- (022)- 42032020	08.11.2023
12.	Reinforcement Bars	TMT (Fe415 to Fe550D), FBE Coated Bars & CRS (Fe415 to Fe550D)	“ELECTRO TMT PLUS” “ELECTRO CRS GOLD”	M/s. Electrotherm India Ltd., Survey No. 325, NH 8A, Nr. Toll Tax Booth, Samkhiyali, Ta. Bhachhau, Dist. Kutch. Gujrat- India	(022)- 65201597 / (02717)- 660649	08.11.2023
13.	Reinforcement Bars	TMT bars of Grade (Fe415, to Fe 550D)	“GUARDIAN”	M/s. Guardian Castings Pvt. Ltd. 415, Mahinder Chambers, W.T. Patil Marg, Opp. Dukes Factory, Chembur, Mumbai-400071	(022)- 67975145 / 5146	08.11.2023
14.	Reinforcement Bars	TMT bars of Grade (Fe 500, Fe 500D & Fe 550D)	“BHAGWATI”	M/s. Bhagwati Steel Cast Pvt. Ltd., D-101, MIDC, Malegaon, Sinner, Dist-Nashik-422113, Maharashtra	022- 40354444 Fax- 40350432	14.10.2022
15.	Reinforcement Bars	TMT bars of Grade (Fe 500, Fe 500D & Fe 550D)	“REGENCY”	M/s. Regency Ispat Pvt. Ltd., 507, Bharat Chambers, Baroda Street, Iron Market, Carnac Bunder, Mumbai - 400009	(0251)- 2703815/ 98201468 15	29.09.2023
16.	Reinforcement Bars	TMT bars of Grade (415 to Fe 550D)	“THANE”	M/s. Thane Steel Limited, 14, Steel Yard House, S.T. Road, Carnac Bunder, Mumbai - 400009	Mob.:- 83560599 49	22.08.2024
17.	Reinforcement Bars	TMT (Fe415 to Fe550D), FBE Coated bars (Fe500 to Fe600) & FBE Coating to	“CAPTAIN”	M/s. Captain Steel India Limited, 10A, Shakespeare Court, 21A, Shakespeare Sarani, Kolkata-700017	(033)- 40112525 / Mob.:- 88731250 00	23.03.2025

		TMT bars				
18.	Reinforcem ent Bars	Non Corrosive SS Rebar of grade SSR 550	“SUNFLAG	M/s. Sunflag Iron & Steel Co. Ltd. 33, Mount Road, Sadar, Nagpur - 440001 (India)	Mob.: -93253602 01/ 93232214 81	31.10.2024
19.	Reinforcem ent Bars	TMT bars of Grade Fe (415 to Fe 500D)	“METRO”	M/s. Metro Ispat Pvt. Ltd., Potia Industrial Estate, 3 RD Floor, Darukhana, Reay Road, Mumbai - 400010	Mob.: -98196819 61	03.12.2024
20.	Reinforcem ent Bars	TMT bars of Grade Fe500, Fe500D, Fe550 & Fe550D	KALIKA	M/s. Kalika Steel Alloys Pvt. Ltd., Office No. 412, Shreekant chambers Premises,Sion Trmobay Road, Chembur, Mumbai – 400071	Mob.: -90499973 11	28.03.2025
21.	Reinforcem ent Bars	TMT bars of Grade Fe500, Fe500D, Fe550 & Fe550D	“KHATU”	M/s. Shri Khatu Shyam Alloys Pvt. Ltd., Survey no. 148/3, Near Parle Biscuit Company, Village-Kharadpada, Silvasa- 396230	Mob.: -99307725 70	16.06.2025
22.	Tiles	Ceramic & Vitrified Tiles (IS 15622:2006)	“DAKSHIN AMURTI”	M/s Akash Ceramic Pvt. Ltd. Complex,3 rd floor, Drive-in cinema road, Ahmedabad-54	(079)- 26857400 /500	25.12.2023
23.	Tiles	Ceramic & Vitrified Tiles (IS 15622:2006)	“AMBANI”	M/s. Ambani Vitrified Pvt. Ltd., Survey No.143 P1/P1, Morbi Charadva Road, Unchi Mandal, Morbi, Gujrat- 363641.	Mob.: -97277231 51/ 90821215 50	06.01.2023
24.	Tiles	Ceramic & Vitrified Tiles (IS 15622:2006)	“VARMOR A”	M/s. Varmora Granito Pvt. Ltd., A-54, 1 st Floor, Elite Auto House, Mathuradas Vasanji Road, Andheri-Kurla Road, Andheri (East), Mumbai –	(022)- 28389790 /91/92	27.09.2023
25.	Tiles	Ceramic & Vitrified Tiles (IS 15622:2006)	“ORIENT BELL”	M/s. Orient Bell Ltd., Iris House, 16 Business Centre, Nangal Raya, New Delhi- 110046	(011)- 47119100	16.10.2023
26.	Tiles	Ceramic & Vitrified Tiles (IS 15622:2006)	RAK	M/s. RAK Ceramics India Pvt. Ltd., 1ST Floor, Carnival House, Opp. Oberoi Mall, Dindoshi Road, Malad East, Mumbai- 400063	Mob.: -99200278 28	22.02.2024
27.	Tiles	Ceramic & Vitrified Tiles IS 15622:2006	CREANZA	M/s. Commander Vitrified Pvt. Ltd., 8-A NH, B/H Landgrace Ceramic, At. Sartanpar, Ta. Wankaner, Morbi, Gujrat- 363621	Mob.: -93208125 11	16.02.2024
28.	Tiles	Ceramic & Vitrified Tiles IS 15622:2006	“ZEALTOP”	M/s. Zealtop Granito Pvt. Ltd., Old Ghantu Road,Morbi, Gujrat -363642	(022)- 28728750 /7585	12.06.2024
29.	Tiles	Ceramic & Vitrified Tiles IS 15622:2006	“PRIYAM GRANTILE	M/s. Solvish Ceramic LLP Survey No. 106/2, Matel Road,Nr. Classy	Mob.: -93242325 44/	25.10.2024

				sanitaryware, Wankaner,Morbi, (Gujrat)- 363622	98338778 21	
30.	Tiles	Ceramic & Vitrified Tiles IS 15622:2006	“SOMANY”	M/s. Somany Ceramics Limited, 401 to 408, Bonanza building, Sahar Plaza, Next to Kohinoor hotel, Andheri-Kurla Road,Andheri (East), Mumbai- 400 059	Mob.:- 75064086 96 / (022)- 40398300	27.02.2025
31.	Tiles	Ceramic & Vitrified Tiles IS 15622:2006	“AGL”	M/s. Asian Granito India Ltd., 202, Dev arc, Opp. Iskon temple, S. G. Highway, Ahmadabad – 380 015	(079)- 66125500 /698	07.04.2025
32.	Sanitary ware	Water Closet /Basin/Urinal Cistern (IS 2556:2004)	RAK	M/s. RAK Ceramics India Pvt. Ltd., 1ST Floor, Carnival House, Opp. Oberoi Mall, Dindoshi Road, Malad East, Mumbai- 400063	Mob.:- 99200278 28	22.02.2024
33.	Sanitary ware	Water Closet /Basin/Urinal Cistern (IS 2556:2004)	PRIYAM GRANTILE	M/s. Solvish Ceramic LLP Survey No. 106/2, Matel Road,Nr. Classy sanitaryware, Wankaner,Morbi, (Gujrat)- 363622	Mob.:- 93242325 44/ 98338778 21	25.10.2024
34.	Cast Iron Pipes & Fittings	CI Pipes (IS 3989:2009)	“NFL”	M/s. Nagpur Foundries Limited, N-72, MIDC, Hingana Road, Nagpur – 440 016.	(0712)- 2768232	06.11.2022
35.	Cast Iron Pipes & Fittings	CI Pipes (IS 3989:2009)	“RPMF”	M/s. Raj Pattern Makers & Founders Pvt. Ltd. Nagla Kishan Lal, Hathras Road, Agra, Uttarpradesh - 282006	Mob.:- 97602832 96	20.03.2025
36.	RCC pipes	NP3 & NP4 class (450 mm - 1800 mm)	“ACPPL”	M/s Aadit Concrete Products Pvt. Ltd. 80/85, Om Laxmi Niwas, Prabhat Main Road, Near Royalty Hotel, Erandwane, Pune-411004.	Mob.- 95525 29191	14.03.2024
37.	RCC pipes	NP2 (150mm - 600mm) NP3 (150mm - 1200mm)	“SHIVAMM ”	M/s. Shivamm Industries, Arihant heights, Plot 76, Sec- 25, Near Gyan Prabhodhini School, Pradhikaran, Nigadi, Pune – 411044	(020)- 27651888	13.08.2022
38.	RCC pipes	NP3 & NP4 class (400 mm - 1800 mm)	“POONA CONCRET E”	M/s. The Poona Concrete Products Co. 996, Navi Peth, Abhinav Apartment, Pune-411030	Mob.:- 99201774 56	14.04.2024
39.	RCC pipes	1) NP2 class (150 mm - 300 mm) 2) NP3 & NP4 class (150 mm -1800 mm)	“PRANALI”	M/s Pranali Cement Pipes Pvt. Ltd, 311,Kesar Krupa CHS Ltd., Above Saraswat Bank Ltd., Chandavarkar Road, Borivali(w), Mumbai-400092	Mob.:- 93246226 69	15.03.2024
40.	RCC pipes	1) NP2 class (100 mm - 600 mm)	“SAGAR SPUN PIPE”	M/s. Sagar Spun Pipes, Plot No. C-9, MIDC Industrial area,	Mob.:- 98222339 99	04.06.2024

		2) NP3 & NP4 class (150 mm -1200 mm)		Waluj, Aurangabad – 431136		
41.	Single Stack System	HDPE Single stack system	“GEBERIT”	Geberit Plumbing Technology India Pvt. Ltd. 305, B-Wing, Dynatsy Bussiness park, Andheri Kurla Road, Andheri (E) Mumbai 400059.	(080) – 23376127 /2357061 2	21.08.2022
42.	PP Pipes & Fittings	“Multi-Layer Polypropylene Silent Pipes & Fittings”	“HULIOT”	M/s Huliot Pipes & Fittings Private Limited. 401, Siddharth Complex, R.C. Dutt Road, Alkapuri, Vadodara, Gujrat-390 007	Mob.:- 90999363 26	26.07.2022
43.	CPVC SWR, uPVC &PVC Pipes	(i) CPVC pipes IS 15778 and CPVC fitting IS7834 (ii) UPVC SWR Pipes IS 13592:1992 & Fittings 14735:1999 (iii) Potables water supply Pipes IS 4985:2000 (iv) uPVC pipes	“TRUFLO BY HINDWAR E	M/s. HSIL Limited, Unit 501 & 504, Block-A, “The Platina”, Survey No. 136, Gachibowli-Miyapur Road, Gachibowli, Hyderabad, Telangana- 500032	(040)- 66288000 Mob.:- 98983489 83	26.03.2025
44.	SWR	UPVC SWR Pipes IS 13592:1992 & Fittings 14735:1999	BIRLA AEROCON	M/s. HIL Limited, L7 Floor, SLN Terminus, Sy. No. 133, Beside Botanical Garden, Gachibowli, Hyderabad- 500 032, Telangana.	Mob.:- 86000040 36	29.03.2024
45.	PPR Pipes & Fittings	PPR Pipes & Fittings (IS 15801:2008 for Hot & Cold water supply)	“KPT GREEN THERM”	M/s. Kanha Plastics Pvt. Ltd., Unit no. 306, PP Trade Center, Plot no. P-1, Netaji Subhash Place, New Delhi-110035	Mob.:- 96340079 85/ 96349044 722	16.08.2023
46.	DWC	DWC Pipes & Fittings (IS 16098:2016	D-REX	M/s. Astral Poly Technik Limited 207/1, Astral House, B/h Rajpath Club, Off. S. G. Highway, Ahmedabad-380059	Mob.:- 81087838 49	29.02.2024
47.	SWR, UPVC, CPVC,& Foam core Pipes	i) SWR Pipes IS 13592:1992 ii)UPVC injection moldings fittings IS14735:1999 iii)CPVC pipes IS 15778 and CPVC fitting IS7834 iv) UPVC Pipes	“ULTRAFIT ” “FLOWGUARD PLUS” “AQUAFIT” “FOAMFIT”	M/s. Prince pipes & Fittings Pvt. Ltd, The Ruby, 8 th floor, 29, Senapati Bapat Marg, (Tulsi pipe road),Dadar (W), Mumbai- 400 028	(022)- 66022222 Fax-(022)- 6602 2220	04.04.2025

		IS4985:2000 v) Foam core pipes IS16098: 2003 vi) upvc Pipe for potable water				
48.	Polypropylene Pipes	PPR Pipes	GREENFIT	M/s. Prince pipes & Fittings Pvt. Ltd, The Ruby, 8 th floor, 29, Senapati Bapat Marg, (Tulsi pipe road),Dadar (W), Mumbai- 400 028	(022)-66022222 Fax-(022)-6602 2220	04.04.2025
49.	High Density Polyethylene Pipes	DWC Pipes	CORFIT	M/s. Prince pipes & Fittings Pvt. Ltd, The Ruby, 8 th floor, 29, Senapati Bapat Marg, (Tulsi pipe road),Dadar (W), Mumbai- 400 028	(022)-66022222 Fax-(022)-6602 2220	04.04.2025
50.	Polyethylene tank	Water Storage Tank	STOREFIT	M/s. Prince pipes & Fittings Pvt. Ltd, The Ruby, 8 th floor, 29, Senapati Bapat Marg, (Tulsi pipe road),Dadar (W), Mumbai- 400 028	(022)-66022222 Fax-(022)-6602 2220	04.04.2025
51.	Chemicals	Construction Chemicals	“SUNANDA”	M/s. Sunanda Speciality Coatings Pvt. Ltd, Satyadham Road no. 2, Sion (E), Mumbai – 400 022	(022)-24034130	17.12.2023
52.	Chemicals	Construction Chemicals	“CICO”	M/s. Cico Technolgies Ltd., AC-10-B/11, Raj Laxmi Commercial Complex, Kalher-Bhiwandi Road, Thane- 421302	(022)-27811913	23.07.2022
53.	Chemicals	Construction Chemicals	“Dr. Fixit” & “ROFF”	M/s. Pidilite Industries Limited, Marketing Division, Ramkrishna Mandir Road, Andheri (E), Mumbai- 400059	Mob.:-84518024 82/ 88284271 30	13.08.2022
54.	Chemicals	Construction Chemicals	“ASWANI”	M/s. Aswani Industries Private Limited, 2ND Floor, Office-25, TPS-4, FP-172, Ascon City, City Light Road, Surat, Gujrat – 395007	Mob.:-98795069 18	22.10.2022
55.	Chemicals	Construction Chemicals	“ASIAN PAINT SMARTCARE”	M/s. Asian Paints Limited, Asian Paints House, 6A, Shanti Nagar Santacruz (E), Mumbai- 400055	(022)-62181000	03.11.2022
56.	Chemicals	Construction Chemicals	“CHRYSO”	M/s. CHRYSO India Private Limited Plot No. D-30/7, TTC Industrial Area, MIDC	Mob.:-95949488 58	16.08.2023

				Turbhe, Navi Mumbai-400705		
57.	Chemicals	Construction Chemicals	“HIND”	M/s. Hindcon Chemicals Limited 62B, Braunfeld Row, Vashudha, Kolkata- 700027	(033)-24490835 /39	02.01.2023
58.	Chemicals	Construction Chemicals	“KRYTON”	M/s. Kryton Buildmat Co. Pvt. Ltd. 136-137, Centrum Plaza, Golf Course Road, Sector 53, Gurugram, Haryana-122002		10.11.2023
59.	Chemicals	Construction Chemicals	“SHREE PRIMIX”	M/s. Shree Premix Industries, 104, Corporate Avenue, Near Udyog Bhavan, Sonawala Lane, Goregaon (East), Mumbai- 400063	(022)-26853022 / 98215418 67/ 70459509 21	11.11.2023
60.	Chemicals	Construction Chemicals	“PERMA”	M/s Perma Construction Aids Pvt. Ltd. 611/612 Nirmal Corporate Centre, Mulund (W) Mumbai-400080	(022)-25903008	25.12.2023
61.	Chemicals	Construction Chemicals	“BOXER”	M/s. Boxer Construction Chemicals, Sudhashil, B-31, Kalidas Colony, Satara Road, Tal- Koregaon, Satara- 400 072	Mob.:- 98509686 26	21.06.2023
62.	Chemicals	Construction Chemicals	“FAIRMAT E	M/s. Fair Mate Chemicals Pvt. Ltd. 8/1, Sai Sudha, Arunoday Soc. Alkapuri, Vadodara (Gujrat)- 390007	(0265)-2358173/ 2331193	22.03.2024
63.	Chemicals	Construction Chemicals	“PAR”	M/s. Par Specialty Polymers Pvt. Ltd. Unit No-309, Turbhe Industrial Park, Plot no. C-56/1, TTC Industrial Area, Turbhe, Navi Mumbai-400705	Mob.:- 96195155 66	18.05.2024
64.	Chemicals	Construction Chemicals		M/s. Tiki Tar Danosa India Pvt. Ltd. Tiki tar state, Village Road, Bhandup (W) Mumbai- 078	(022)-41266699	06.06.2024
65.	Chemicals	Construction Chemicals		M/s. Rheoplast Technology Pvt. Ltd., 711, A Wing, Mainframe-1, Royal Palm, 169 Aarey Colony, Goregaon (E), Mumbai-400065	Mob.:- 80804440 30	10.10.2024
66.	Chemicals	Construction Chemicals		M/s. Fosroc Chemicals (India) Pvt. Ltd., Embassy Point, No. 150, 2ND Floor, Infantry Road, Bengaluru – 560001	Mob.:- 84339734 13	27.02.2025
67.	Chemicals	Construction Chemicals		M/s Krishna Conchem Product Ltd. Unit-2, Bldg. 6, Sect. 3, Millennium Business Park, Mahape, Navi Mumbai-	(022)-32986329 / 27782923 /	21.09.2024

				400710	09324924 398	
68.	AAC Block	AAC Block	BIRLA AEROCON	M/s. HIL Limited, L7 Floor, SLN Terminus, Sy. No. 133, Beside Botanical Garden, Gachibowli, Hyderabad- 500 032, Telangana	Mob.:- 86000040 36	29.03.2024
69.	AAC Block	AAC Block	MAGICRE TE	M/s. Magicrete Building Solutions Pvt. Ltd. 702, 22 Business Point, S. V. Road, Andheri (West), Mumbai-400058	Mob.:- 99704652 15	22.06.2024
70.	Ready to use Mortar	Ready Mix Mortar & Block Jointing Mortar	MAGICRE TE	M/s. Magicrete Building Solutions Pvt. Ltd. 702, 22 Business Point, S. V. Road, Andheri (West), Mumbai-400058	Mob.:- 99704652 15	22.06.2024
71.	Ready to use Mortar	Ready Mix Mortar &Block Jointing Mortar	“SILICOPL AST &SILICOF LEX”	M/s. Precise Conchem Pvt. Ltd., 202, The Great Eastern Chambers Premises, Plot-28, Sector-11, CBD Belapur – 400 614	(022)- 27562962 / +91- 93200586 35	26.03.2023
72.	Ready to use Mortar	Ready Mix Mortar & Block Jointing Mortar	“KANERIA”	M/s. Kaneria Plast Pvt. Ltd. 6TH Floor, Rohan Arcade, Off W.E.Highway, Dattani Park, Thakur Village, Kandivali (E), Mumbai- 400101	Mob.:- 82918924 01/ 82918924 14	25.10.2024
73.	Paints	External and Internal Paints	“PEARL/ COLORTE X/ KLASSIC/ UNO/ INSPIRA	M/s. Godavari paints Pvt. Ltd., Tulsiram Gupta Mills Estate, Darukhana, Reay Road, Mumbai 400010	(022)- 23723227	05.02.2024
74.	Paints	External and Internal Paints	SNOWCE M	M/s. Snowcem Paints Private Limited, 702 A, Pranik Chambers, Saki Vihar Road, Andheri (E), Mumbai – 400072	(022)- 28573551 / 28572700	25.10.2023
75.	Paints	External and Internal Paints		M/s. Advance Paints Pvt. Ltd. Advance House, Plot no. A, Ark Industrial Compound, Makwana Road, Marol Naka, Andheri (E), Mumbai – 400059	(022)- 28590162 /63/64	16.12.2023
76.	Paints	External and Internal Paints	“FAIRCOA T, FAIRTEX, FAIRSHIN E, FAIRLOOK ”	M/s. Hindusthan Paints and products, 11-A New Empire industrial Estate, Kondivita road Andheri(E), Mumbai 400059	(022)- 28223341	06.05.2024
77.	Paints	External Paints	--	M/s. Dooall Corpro India Pvt. Ltd. 315, Bhaveshwar Arcade Annexe,LBS Road, Ghatkopar (West)-400086	Mob.:- 98208744 10	22.08.2024

78.	Paints	External and Internal Paints	--	M/s. Excel India Protective Paints Pvt. Ltd. A-33 & 34, MIDC Kulgaon, Badlapur, Thane-421503	Mob.:- 98922270 39 (0251)- 2695520	20.10.2024
79.	FRP Cover with Frames	Manhole cover with frames and Grating with Frames	"KK"	M/s, K. K. Manhole & Grating Co. Plot. No. A-47 & 119/120/129, STICE, Shirdi Road, Sinner, Nashik. Maharashtra – 422103.	(0253) - 2340556	02.09.2022
80.	SFRC Cover with Frames	Manhole cover with frames and Grating with Frames	"KK"	M/s, K. K. Manhole & Grating Co. Plot. No. A-47 & 119/120/129, STICE, Shirdi Road, Sinner, Nashik. Maharashtra – 422103.	(0253) - 2340556	20.04.2023
81.	SFRC Cover with Frames	Manhole cover with frames and Grating with Frames	"VIKRANT"	M/s. Vikrant Reinforced Products Pipewala Compound, Opp Unionbank, Near Chembur Police station, Chembur, Mumbai- 400074	Mob.:- 98692508 44	06.09.2024
82.	FRP Cover with Frames	Manhole cover with frames and Grating with Frames	"STRONG DRAIN"	M/s HP Adhesives Private Limited. 11, Unique House, Chakala, Andheri (East), Mumbai – 400099	Mob.:- 98672549 25	13.08.2022
83.	Ductile iron Covers with Frames	DI Manhole covers with Frame and Gratings	"PLASMA"	M/s Plasma Alloys Pvt. Ltd. Survey No.196,N.H.27,Gondal Road Veraval (Shapar) Dist-Rajkot-360 024 Gujrat	(02827)- 253766 Fax- (02827)- 253966	29.11.2024
84.	Ductile iron Covers with Frames	DI Manhole covers & Frame and Gratings	"GOLDSTAR"	M/s. Gold Star Steels (P) Ltd. 53/A, Industrial Area, Bhanpuri, P.O. Birgaon, Raipur-493221,Chattisgarh	Mob.:- 98203178 75	23.09.2022
85.	Ductile iron & Cast iron Covers with Frames	DI & CI Manhole covers with Frame and Gratings	"RBA"	M/s. RBA Exports Private Limited, 2/6, Sarat Bose Road, Central Plaza, Suit No. 606, 6 TH Floor, Kolkata-700020	Mob.:- 98339925 57	12.12.2022
86.	Ductile iron Covers with Frames	DI Manhole covers with Frame and Gratings	"NEXUS"	M/s. Nexus Cast S. R. No. 128, Plot 1, Gaurav Industrial area,Opp. 132 KV Substation, Nr. Sardar Chowk,Rajkot -360024	Mob.:- 70211409 73	01.11.2024
87.	Ductile iron & Cast iron Covers with Frames	DI & CI Manhole covers with Frame and Gratings	"RPMF"	M/s. Raj Pattern Makers & Founders Pvt. Ltd. Nagla Kishan Lal, Hathras Road, Agra, Uttarpradesh - 282006	Mob.:- 97602832 96	20.03.2025
88.	Door Shutter & Frame	FRP Door Shutter & Frame	"SANCOM"	M/s. Sancom Composites LLP Gala No. 123, Blue Rose Industrial Estate, W.E. Highway, Borivali (E), Mumbai – 400066	Mob.:- 93236574 15	17.03.2023
89.	Door Shutter & Frame	FRP Door Shutter & Frame	"PERMAFINISH"	M/s. Advance FRP, 4, Avinash Bhuvan, Next to Gujarati School,Kankuwadi Dixit Cross Road no. 1, Vile Parle (E), Mumbai- 400057	(022)- 26175636 / 26122376	07.10.2024
90.	Door	Flush, Panel,	"KALPTAR"	M/s. V. K. Patel & Co.,	82919731	13.05.2024

	Shutter & Frame, Plywood, Block Board,	Fire retardant Wooden Doors, Plywood, Block board, Laminates, Veneer	U	G 2, 3, & 4, Mahesh Darshan, Near Makhmali Talao, old Agra Road, Thane (West) – 400601	09/ (022) 25431548 / 96199359 55	
91.	Door Shutter & Frame, Plywood, Block Board,	Flush wooden Doors, Plywood, Block board,	“REGENCY	M/s Regal Plywood Industries (P) Ltd. C/o, M/s. Regency Wood Panel Pvt. Ltd. 106, 1st Floor, Palm Beach Galleria, Plot no. 17, Sec-19D, Vashi, Navi Mumbai-400703.	Mob.:- 98208111 75/ 96193611 49	27.02.2025
92.	Railing	Aluminum Railing	ENDURAIL	M/s. Chemey Techsolutions LLP, 202-Campus Corner, Nr. St. Xavier’s Collage Corner, Navrangpura, Ahmedabad-380009	Mob.:- 99252055 52	15.08.2022
93.	Fire Door & Non Fire Door	Fire Door & Non Fire Door	“HORMAN N”	M/s. Shakti Hormann Pvt. Ltd. H. No. 2-67/1, (Survey No. 188, 198).Gagillapur, Dundigal Municipality, Mandal, Dist-Medchal (Malkajgiri), Telangana-500043	+ (40)- 27840394 /5	30.09.2024
94.	Geosynthetic Fibre	Non Woven Geo Textile, Geo Grid, Membrane, Mats, Nets	“JEEVAN”	M/s. Jeevan Products, Kailas Business Park, Kailas Complex, Powai Vikhroli Link road, Veer Sawarkar Marg, Park Site, Vikhroli (West), Mumbai – 400 079	Mob.:- 70459093 72	02.01.2023
95.	Carbon Fibre & Glass Fibre	Carbon Fiber, Glass Fiber & Carbon Laminate Strips	“URJA”	M/s. Urja Products Pvt. Ltd., Survey No. 53, Inside Pirana Gate, Before Ode Village, Nr Cow Circle on outer Ring Road, Piplej-Pirana, Ahmedabad, Gujrat – 382427	Mob.:- 98215762 79	19.01.2023
96.	Vinyl Flooring	Vinyl	“RESPONSIVE”	M/s. Responsive Industries Limited, Mahagaon Road, Betegaon Village, Boisar (East), Palghar-401501	(022)- 66562727 /2704	19.01.2023
97.	Cladding	Aluminium Composite Cladding (ACP)	“VIVA”	M/s. Viva Composite Panel (P) Ltd. Unit No. 7, New Tejpal Industrial Area, Andheri Kurla Road, Sakinaka, Andhri (E), Mumbai-400072	(022)- 28500150 /151/152	16.02.2023
98.	Cladding	Aluminium Composite Cladding (ACP)	“ALUDECOR”	M/s. Aludecor Lamination Pvt. Ltd., Suit no. 52, 5TH floor, R.N. Mukherjee Road, Kolkata-700001, West Bengal	(022)- 26866633 / 98675730 5	16.08.2023
99.	Cladding	Aluminium Composite Cladding (ACP)	“EUROBOND”	M/s. Euro Panel Products Pvt. Ltd., 702, Aravali Business Centre, Ramdas Sutrale Road, Borivali (West), Mumbai-400092	(022)- 29686500	11.11.2023

100.	Cladding	Aluminium Composite Cladding (ACP)	“SUPERBOND”	M/s. Keybond Industries LLP, 17, Super House, Amar Brass Ind. Estate, CST Road, Santacruz (East), Mumbai-400092	(022)-66758380 /8359	27.07.2024
101.	Precast RCC products	Precast RCC Drain, Box Culverts & Retaining wall	“FUJI”	M/s Fuji Silvertch Concrete Pvt. Ltd. 4TH Floor, House no. 5, Magnet Corporate Park, Nr. Sola Flyover, SG Road, Thaltej, Ahmedabad- 380054, Gujrat.	(079)-40210000 / 9833711834	01.11.2023
102.	Precast RCC products	Manhole Covers, Precast RCC Drain	“SUPER”	M/S Super Cement Article Plot. No. B-49, Behind Union Bank, NICE Area, Satpur MIDC, Nashik-422007	Mob.:- 9869032374 / 9869085007	27.05.2024
103.	Glass	Float, Mirror,	GOLD PLUS	M/s. Gold Plus Glass Industry Limited, 4TH Floor, Kings Mall, Sector-10, Rohoni, New Delhi-110085	Mob.:- 9730041833	04.04.2025
104.	Others	Gypsum plaster/bond/ Wall putty/ False ceiling/Partition sections	WIP	M/s. Western Infrabuild Products LLP A-592, TTC Industrial Area, MIDC Mahape, Navi Mumbai-400701	Mob.:- 7498196768	23.03.2025

Note: This list of approved building materials supersedes the earlier list of approved building materials. All the conditions mentioned in the letter of approval shall be scrupulously adhered to by the site engineering staff. In case of ISI marked brands, the latest valid BIS endorsement shall be insisted from the manufacturer. The valid list of approved Building Materials at the time of execution of works can be obtained from Dy. Ch. Eng. (B.M.) City's office OR MCGM portal under tab- Services -->Citizen Charters --> Chief Eng Building Maintenance OR under tab 'About Us-->Wards/Departments --> Chief Eng Building Maintenance-->Docs.

SD/-
01.07.2022
Dy. Ch. Eng. (B.M.) City

SECTION 11

FRAUD AND CORRUPT PRACTICES

FRAUD AND CORRUPT PRACTICES

The Applicants and their respective officers, employees, agents and advisers shall observe the highest standard of ethics during the Bidding Process. Notwithstanding anything to the contrary contained herein, the Authority may reject an Application without being liable in any manner whatsoever to the Applicant if it determines that the Applicant has, directly or indirectly or through an agent, engaged in corrupt practice, fraudulent practice, coercive practice, undesirable practice or restrictive practice in the Bidding Process.

Without prejudice to the rights of the Authority under relevant Clause hereinabove, if an Applicant is found by the Authority to have directly or indirectly or through an agent, engaged or indulged in any corrupt practice, fraudulent practice, coercive practice, undesirable practice or restrictive practice during the Bidding Process, such Applicant shall not be eligible to participate in any tender or RFQ issued by the Authority during a period of 2 (two) years from the date such Applicant is found by the Authority to have directly or indirectly or through an agent, engaged or indulged in any corrupt practice, fraudulent practice, coercive practice, undesirable practice or restrictive practice, as the case may be.

For the purposes of this Clause, the following terms shall have the meaning hereinafter respectively assigned to them:

- A. “corrupt practice”** means the offering, giving, receiving, or soliciting, directly or indirectly, of anything of value to influence the actions of any person connected with the Bidding Process (for avoidance of doubt, offering of employment to, or employing, or engaging in any manner whatsoever, directly or indirectly, any official of the Authority who is or has been associated in any manner, directly or indirectly, with the Bidding Process or the LOA or has dealt with matters concerning the Concession Agreement or arising there from, before or after the execution thereof, at any time prior to the expiry of one year from the date such official resigns or retires from or otherwise ceases to be in

the service of the Authority, shall be deemed to constitute influencing the actions of a person connected with the Bidding Process); or

save and except as permitted under the relevant sub clause, engaging in any manner whatsoever, whether during the Bidding Process or after the issue of the LOA or after the execution of the Concession Agreement, as the case may be, any person in respect of any matter relating to the Project or the LOA or the Concession Agreement, who at any time has been or is a legal, financial or technical adviser of the Authority in relation to any matter concerning the Project;

- B. “fraudulent practice”** means a misrepresentation or omission of facts or suppression of facts or disclosure of incomplete facts, in order to influence the Bidding Process;
- C. “coercive practice”** means impairing or harming or threatening to impair or harm, directly or indirectly, any person or property to influence any person’s participation or action in the Bidding Process;
- D. “undesirable practice”** means (i) establishing contact with any person connected with or employed or engaged by the Authority with the objective of canvassing, lobbying or in any manner influencing or attempting to influence the Bidding Process; or (ii) having a Conflict of Interest; and
- E. “Restrictive practice”** means forming a cartel or arriving at any understanding or arrangement among Applicants with the objective of restricting or manipulating a full and fair competition in the Bidding Process.
- F.** If the Employer/Financier determines that the Contractor has engaged in corrupt, fraudulent, collusive, coercive or obstructive practices, in competing for or in executing the Contract, then the Employer may, after giving 14 days’ notice to the Contractor, terminate the Contractor's employment under the Contract and expel him from the Site, and the provisions of relevant Clause shall apply as if such expulsion had been made.
- G.** Should any employee of the Contractor be determined to have engaged in corrupt, fraudulent, collusive, coercive, or obstructive practice during the

execution of the Works, then that employee shall be removed in accordance with relevant Clause.

For the purposes of this Sub-Clause:

- i. “corrupt practice” is the offering, giving, receiving to soliciting, directly or indirectly, of anything of value to influence improperly the actions of another party;
- ii. “another party” refers to a public official acting in relation to the procurement process or contract execution. In this context, “public official” includes Financer staff and employees of other organizations taking or reviewing procurement decisions.
- iii. “fraudulent practice” is any act or omission, including a misrepresentation, that knowingly or recklessly misleads, or attempts to mislead, a party to obtain a financial or other benefit or to avoid an obligation;
- iv. “collusive practice” is an arrangement between two or more parties designed to achieve an improper purpose, including to influence improperly the actions of another party;
- v. “coercive practice” is impairing or harming, or threatening to impair or harm, directly or indirectly, any party or the property of the party to influence improperly the actions of a party;
- vi. “obstructive practice” is deliberately destroying, falsifying, altering or concealing of evidence material to the investigation or making false statements to investigators in order to materially impede the Financier investigation into allegations of a corrupt, fraudulent, coercive or collusive practice; and/or threatening, harassing or intimidating any party to prevent it from disclosing its knowledge of matters relevant to the investigation or from pursuing the investigation; or
- vii. acts intended to materially impede the exercise of the Financer’s inspection and audit rights provided .

- viii. “party” refers to a public official; the terms “benefit” and “obligation” relate to the procurement process or contract execution; and the “act or omission” is intended to influence the procurement process or contract execution.
- ix. ”parties” refers to participants in the procurement process (including public officials) attempting to establish bid prices at artificial, non-competitive levels.
- x. a “party” refers to a participant in the procurement process or contract execution.

SECTION 12

PRE BID MEETING

PREBID MEETING

Not Applicable.

SECTION -13

LIST OF APPROVED BANKS

LIST OF APPROVED BANKS

1. The following Banks with their branches in Greater Mumbai and in suburbs and extended suburbs up to Virar and Kalyan have been approved only for the purpose of accepting Banker's guarantee from 1997-98 onwards until further instructions.

2. The Bankers Guarantee issued by branches of approved Banks beyond Kalyan and Virar can be accepted only if the said Banker's Guarantee is countersigned by the Manager of a branch of the same Bank, within the Mumbai Limit categorically endorsing thereon that said bankers Guarantee is binding on the endorsing Branch of the bank within Mumbai limits and is liable to be on forced against the said branch of the Bank in case of default by the contractor/supplier furnishing the bankers Guarantee.

List of approved Banks:-

A	S.B.I and its subsidiary Banks
1	State Bank Of India.
2	State Bank Of Bikaner & Jaipur.
3	State Bank Of Hyderabad.
4	State Bank Of Mysore.
5	State Bank Of Patiyala.
6	State Bank Of Saurashtra.
7	State Bank Of Travankore.
B	Nationalized Banks
8	Allahabad Bank.
9	Andhra Bank.
10	Bank Of Baroda.
11	Bank Of India.
12	Bank Of Maharashtra.
13	Central Bank Of India.
14	Dena Bank.
15	Indian Bank.
16	Indian Overseas Bank.
17	Oriental Bank Of Commerce.
18	Punjab National Bank.
19	Punjab & Sindh Bank.
20	Syndicate Bank.
21	Union Bank Of India.
22	United Bank Of India.
23	UCO Bank.
24	Vijaya Bank.
24A	Corporation Bank.

C	Scheduled Commercial Banks
25	Bank Of Madura Ltd.
26	Bank Of Rajasthan Ltd.
27	Banaras State Bank Ltd.
28	Bharat Overseas Bank Ltd
29	Catholic Syrian Bank Ltd.
30	City Union Bank Ltd.
31	Development Credit Bank.
32	Dhanalakshmi Bank Ltd.
33	Federal Bank Ltd.
34	Indsind Bank Ltd.
35	I.C.I.C.I Banking Corporation Ltd.
36	Global Trust Bank Ltd.
37	Jammu & Kashmir Bank Ltd.
38	Karnataka Bank Ltd.
39	KarurVysya Bank Ltd.
40	Laxmi Vilas Bank Ltd.
41	Nedugundi Bank Ltd.
42	Ratnakar Bank Ltd.
43	Sangli Bank Ltd.
44	South Indian Bank Ltd.
45	S.B.I Corporation &Int Bank Ltd.
46	Tamilnadu Mercantile Bank Ltd.
47	United Western Bank Ltd.
48	Vysya Bank Ltd.
D	Schedule Urban Co-op Banks
49	Abhyudaya Co-op Bank Ltd.
50	Bassein Catholic Co-op Bank Ltd.
51	Bharat Co-op Bank Ltd.
52	Bombay Mercantile Co-op Bank Ltd.
53	Cosmos Co-op Bank Ltd.
54	Greater Mumbai Co-op Bank Ltd.
55	JanataSahakari Bank Ltd.
56	Mumbai District Central Co-op Bank Ltd.
57	Maharashtra State Co-op Bank Ltd.
58	New India Co-op Bank Ltd.
59	North Canara G.S.B. Co-op Bank Ltd.
60	Rupee Co-op Bank Ltd.
61	Sangli Urban Co-op Bank Ltd.
62	Saraswat Co-op Bank Ltd.
63	ShamraoVithal Co-op Bank Ltd.
64	Mahanagar Co-op Bank Ltd.
65	Citizen Bank Ltd.
66	Yes Bank Ltd.
E	Foreign Banks
67	ABM AMRO (N.Y.) Bank.
68	American Express Bank Ltd.
69	ANZ Grindlays Bank Ltd.
70	Bank Of America N.T. & S.A.
71	Bank Of Tokyo Ltd.

72	Bankindosuez.
73	BanqueNationale de Paris.
74	Barclays bank.
75	City Bank N.A.
76	Hongkong& Shanghai banking Corporation.
77	Mitsui Taiyokbe Bank Ltd.
78	Standard Chartered Bank.
79	Cho Hung Bank.

SECTION -14
SPECIAL DIRECTIONS TO THE TENDERER

SPECIAL DIRECTIONS TO THE TENDERER

1. The rate quoted shall be inclusive of transporting and disposal of surplus excavated material.
2. The percentage quoted shall include the cost of any unforeseen item of work connected with the work in question required for the proper execution of the work.
3. The materials used shall confirm to the related ISI specifications as well as MCGM specified specification wherever applicable. Directives of Engineer concerned will be binding.
4. The water supply to the user department shall not be disturbed during execution of the work. Contractor shall make alternate arrangement for providing equivalent capacity tank to restore water supply at their own cost.
5. Maximum care should be taken to the satisfaction of the Engineer to provide and maintain adequate protection to all electrical and mechanical installations. No extra payment will be made on this account under any circumstances.
6. Contractor will have to make their own arrangement for getting the electric supply / temporary electric meter on site for fabrication and allied works at their own cost.
7. The contractor shall intimate the concerned authorities before starting the work and execute the work on priority fixed by the Engineer-in-charge. The inventory of serviceable and unserviceable material must be taken jointly with Site-in-charge (Sub-Engineer) before starting of work.
8. No separate payment will be made for dewatering the water seeping in the trenches and foundation pits opened while executing excavation and other foundation works. The possibility of high water table should be kept in mind while quoting the percentage.
9. While excavating the trenches for foundation utmost care shall be taken that the foundation of adjoining structures will not be disturbed.
10. Materials brought on the site or debris will not be allowed to be stacked in passages or in the car park area.

11. After completion of the waterproofing work, the leakage test shall be carried out after impounding the water and plugging the openings at least for ten days, without any extra cost.
12. Plumbing and sanitary works will have to be carried out through licensed plumber. All plumbing lines will be provided 2" away from wall with spaces as directed. The horizontal and vertical lines should be in line & level.
13. The centering shall be provided only in M.S. plates and M.S. pipe props.
14. Engineer in-charge reserves the right to delete any item, alter / reduce the scope of the work, no extra claim in this respect will be allowed.
15. Water Proofing Treatment layer should not be removed manually, the layer have to be removed by battery operated cutter only. No extra payment will be made.
16. Staircase will not be allowed for transport of materials and contractor will have to provide mechanical lift or pulley at their own cost. No extra payment will be made for this arrangement.
17. The contractor shall have to arrange to carry out the work during night time also as per urgency of the work, at no extra cost with prior approval from Engineer in-charge.
18. After completion of the proposed work, the tenderer/ contractor will have to hand over the site in neat and clean condition for which no extra payment will be made.
19. On receipt of the work order the contractor will have to erect ready-made site Chowky and Godown in form of porta cabin/container cabin. Before erecting the Chowky and Godown, he shall have to obtain permission from the concerned Assistant Commissioner and the Assistant Commissioner shall approve the site of the Chowky and Godown proposed by the Engineer or may allot another suitable site. The porta cabin/ container shall preferably ad measure 12.20 m x 2.50 m with two doors and proper ventilation. It should have toilet facility & lighting arrangement.

The contractor has to provide for site office as per requirement either on his/ her owned place or rented/ leased place. Cost for this may be charged to MCGM by incorporating in the offer. No separate payment may be made for providing the

chowky and ancillary items. No permission and space for site chowky will be given / provided on Municipal road/ footpath. The contractor has to make their own arrangement on hire/ lease for site office.

20.The noise level shall be maintained within the permissible limit in Silence Zone area during the construction activities by the Contractors as per the notification dated 14-02-2000 issued by the Ministry of Environment and Forests.

21.Municipal Corporation of Greater Mumbai do not have site available for disposal of Debris / Demolition material / excavated earth. The Contractor shall dispose these materials properly at his own risk & cost. The contractor shall quote the tender keeping these in mind. No separate payment shall be made for disposal of these Debris / Demolition material / excavated earth.

22.It is mandatory for the contractor to maintain the Noise level during the construction activity within the permissible limits as prescribed by MCGM as per circular under no. CE/PD/7788/I dt. 05/11/2008.

23.The serviceable material of MCGM obtained during work, such as M.S. Grills, reinforcement, structural pipes & MS props if provided etc. shall be handed over in the custody of concerned A.E. (Maint) of concerned ward by taking & maintaining the proper inventories of the serviceable materials.

24.Tenderer/bidders shall take proper care while carrying out repairing work of electrical cabins as switchgears & other electrical items needs to be shifted carefully to avoid any mishap, theft & to have continuous supply on site in consultation with Ch.E(M & E) staff.

25.No extra payment shall be made to make appropriate provision to close door, window & opening as and where necessary to avoid breakage of glass and entry of dust during operation using 6 mm commercial plywood. Contractor shall quote the tender by taking note of it.

26.Appointment of Licensed Structural Engineer by successful bidders for execution of work. However no payment will be permitted to such Licensed Structural Engineer by the MCGM.

a. The contractor shall appoint / avail the services of Structural Engineer registered with MCGM to supervise/ periodically supervise the structural repair

work at his own cost and submit his consent along with his registration / license certificate before starting the work.

- b. The above said registered structural Engineer shall issue a certificate after completion of structural repair work certifying that the structural repairs have been carried out under his supervision and the repairs are carried out satisfactory according to him as per structural audit report. This certificate should also state that the structure after repairs is stable & fit for human habitation. (i.e. structural stability certificate)

27. No extra payment shall be paid for removing and refixing of windows MS grill / aluminium grill. Contractor shall quote the tender by taking note of it.

28. Work of Deco-grill shall not be allowed in view of circular to this effect.

29. The contractor shall carry out periodic medical check up of employees working under him.

30. Penalty to the contractor shall be as per the recent GCC.

31. The debris / every waste generated during the repair works shall be disposed as per circular no. Dy.Ch.E./S.W.M./3957/ Op dt.28.09.2018.

32. Contractor shall provide a Personal Computer/ Laptop of latest configuration with internet facility, at site for day to day work, for Municipal staff.

33. Contractor shall make necessary arrangement to shift the existing MGL gas pipe line during the work and refix the same at the contractor's risk & cost by officially coordinating with Mahanagar Gas Ltd. / appropriate authority. The work shall be carried out under the strict supervision of MGL authority.

SECTION -15
APPENDIX

FORM OF TENDER

To,

The Municipal Commissioner for Greater Mumbai

Sir,

I/ We have read and examined the following documents relating to the construction of _____

_____General

condition of contract for Civil Works of the Municipal Corporation of Greater Mumbai effective from 1.4.2000 with amendment to Clause No. 74(b) as per Circular No. CA/WSSD/I dated 9.4.2002 and Clause no. 96 as per circular no. AMC/P/M/1511 of 29.5.2002

Notice inviting tender.

- a. Directions to tenderers (General and special)
- b. General condition of contract for Civil Works of the Municipal Corporation of Greater Mumbai as amended up to date.
- c. Relevant drawings
- d. Specifications.
- e. Special directions
- f. Annexure A and B.
- g. Bill of Quantities and Rates.

1A. I/We _____

(full name in capital letters, starting with surname), the Proprietor/ Managing Partner/ Managing Director/ Holder of the Business, for the establishment / firm / registered company, named herein below, do hereby offer to MCGM for Major Structural Repairs to Municipal Buildings known as 50 Tenements & 72 Tenements at Peru Chawl, Gas Company lane, Lalbaug F/South ward., Referred to in the specifications and schedule to the accompanying form of contract of the

rates entered in the schedule of rates sent herewith and signed by me/ us” (strike out the portions which are not applicable).

1B. I/We do hereby state and declare that I/We, whose names are given herein below in details with the addresses, have not filled in this tender under any other name or under the name of any other establishment /firm or otherwise, nor are we in any way related or concerned with the establishment /firm or any other person, who have filled in the tender for the aforesaid work.”

2. I/We hereby tender for the execution of the works referred to in the aforesaid documents, upon the terms and conditions, contained or referred to therein and in accordance with the specifications designs, drawings and other relevant details in all respects.

* At the rates entered in the aforesaid Bill of Quantities and Rates.

3. According to your requirements for payment of Earnest Money amounting to Rs. 3,32,900/-**(Rupees Three LakhThirty Two thousand Nine Hundred Only)**.

*(a) I/We have deposited the amount through online payment gateways with the C.E of the corporation not to bear interest.

4. I/We hereby request you not to enter into a contract with any other person/s for the execution of the works until notice of non/acceptance of this tender has first been communicated to me/us, and in consideration of yours agreeing to refrain from so doing I/we agree not to withdraw the offer constituted by this tender before the date of communication to me/us of such notice of non/acceptance, which date shall be not later than ten days from the date of the decision of the Standing Committee or Education Committee of the Corporation, as maybe required under the Mumbai Municipal Corporation Act, not to accept this tender.(Subject to condition 5 below).

5. I/We also agree to keep this tender open for acceptance for a period of 120 days from the date fixed for opening the same and not to make any

modifications in its terms and conditions which are not acceptable to the Corporation.

6. I/We agree that the Corporation shall, without prejudice to any other right or remedy, be at liberty to forfeit the said earnest money absolutely, if.

a. I/We fail to keep the tender open as aforesaid.

b. I/We fail to execute the formal contract or make the contract deposit when called upon to do so.

c. I/we do not commence the work on or before the date specified by the Engineer in his work order.

7. I/We hereby further agree to pay all the charges of whatsoever nature in connection with the preparation, stamping and execution of the said contract.

8. I/We further agree that, I/we shall register ourselves as 'Employer' with the Bombay Iron and Steel Labour Board' and fulfill all the obligatory provisions of Maharashtra Mathadi, Hamal and other Manual workers (Regulation of Employment and Welfare) Act 1969 and the Bombay Iron and Steel unprotected workers Scheme 1970.

9. "I/We..... have failed in the accompanying tender with full knowledge of liabilities and, therefore, we will not raise any objection or dispute in any manner relating to any action, including forfeiture of deposit and blacklisting, for giving any information, which is found to be incorrect and against the instructions and directions given in this tender.

10. "I/We further agree and undertake that in the event it is revealed subsequently after the allotment of work/contract to me/us, that any information given by me/us in this tender is false or incorrect, I/We shall compensate the Municipal Corporation of Greater Mumbai for any such losses or inconvenience caused to the Corporation in any manner and will not resist any claim for such compensation on any ground whatsoever. I/we agree and undertake that I/we shall not claim in such case any amount by way of

damages or compensation for cancellation of the contract given to me/us or any work assigned to me/us or is withdrawn by the Corporation,”

Address

Yours

faithfully,

.....

.....

Signature of the Tenderer or the Firm

1.

2.

3.

4.

5.

Full Name and private residential address of all the partners constituting the Firm		A/c No.....
1	Name of the branch
2
3	Name of the branch
4

5	Vendor No.....
---	-------	----------------

AGREEMENT FORM

Tender / Quotation

dated 20...

Standing Committee/Education Committee Resolution No.
.....

CONTRACT FOR THE WORKS
.....
.....
.....
.....

This agreement made this day of
.....

Two thousand
..... Between
.....
.....

inhabitants of Mumbai, carrying on business at.....
.....
.....

in Bombay under the style and name of Messrs
.....
..... (Hereinafter called "the contractor of the one
part and Shri
.....

the Director(E.S.&P.) (hereinafter called "the commissioner" in which expression
are included unless the inclusion is inconsistent with the context, or meaning

thereof, his successor or successors for the time being holding the office of Director (E,S.& P)of the second part and the Municipal Corporation of Greater Mumbai (hereinafter called “the Corporation”) of the third part, WHEREAS the contractor has tendered for the construction, completion and maintenance of the works described above and his tender has been accepted by the Commissioner (with the approval of the Standing Committee/Education Committee of the Corporation NOW THIS AGREEMENT WITNESSETH as follows:-

1. In this agreement words and expressions shall have the same meanings as are respectively assigned to them in the General Conditions of Contract for works hereinafter referred to:-
2. The following documents shall be deemed to form and be read and constructed as a part of this agreement viz.
 - a. The said Tender
 - b. The Drawings
 - c. The Specifications
 - d. General condition of contract for Civil Works of the Municipal Corporation of Greater Mumbai as amended up to date
3. In consideration of the payments to be made by the Commissioner to the contractor as hereinafter mentioned the contractor hereby covenants with the Commissioner to construct, complete and maintain the works in conformity in all respects with the provision of the contract.
4. The Commissioner hereby covenants to pay to the Contractor in consideration of the construction, completion and maintenance of the works the contract sum, at times and in the manner prescribed by the contract.

IN WITNESS WHERE OF the parties hereto have caused their respective common seals to be herein to affixed (or have hereunto set their respective hands and seals) the day and year above written.

<p>Signed with designation stamp of the Contractor, sealed and delivered by the contractor/s</p>	<p style="text-align: center;">Seal</p>
--	--

Trading under the name and style of		
In the presence of the witness : Witness No.1: Name &Address Name:- Resi.address:-		Signature of Witness no.1
Witness No.2: Name &Address Name:- Resi.address:-		Signature of Witness no.2
Signed by the Dy. Municipal Commissioner, The Director (ES & P) in the presence of 1. 2.		Director (ES&P)
Name and signature of concern Dy.Ch.Eng. & Ch.E. (HOD) with Designation Stamp		Dy.Ch.E.(Eng.) Ch.E. (B.M.) Shri/Smt., Shri/Smt.,

<p>The Common seal of the Municipal Corporation of Greater Mumbai was hereunto affixed on theday of _____.____.20__ presence of</p> <ol style="list-style-type: none"> 1. 2. <p>two members of the Standing Committee of the Municipal Corporation of Greater Mumbai</p>	
<p>Witness:- (Shri/Smt. _____) Office Superintendent, Municipal Secretary's office</p> <p>Contract examined with the Quotation/Tender and the Resolution No. _____ dated _____ of the Standing /Educaion Committee/Municipal Commissioner/ Director (ES&P)'s Sanction No. _____ dated _____ etc. And found correct.</p>	

Signature of Asst.Eng.orEx.Eng and Dy.ch.Eng.Of the concerned deptt. With designation stamp

ANNEXURE A

Name of the work: - Major Structural Repairs to Municipal Buildings known as 50 Tenements & 72 Tenements at Peru Chawl, Gas Company lane , Lalbaug in F/South ward.			
1.	The Engineer for this work will be	Chief Engineer (B.M) Dy.Chief Engr. (B.M) City Executive Engr. (B.M)City-II	
2.	Estimated cost of Tender		
a.	Civil works	Rs.2,55,76,905.00/-	
b.	Mechanical & Electrical works	Rs.77,09,704.00/-	
c.	Landscaping works	Nil	
d.	Interior & Furniture works	Nil	
	Total	Rs.3,32,86,609.00/-	
3.	Earnest Money (1% of the Estimated cost in the form of D.D.)	Rs. 3,32,900.00/-	
4.	Time Period		
1.	Contract as a whole Period completion	12 months (* Inclusive of Monsoon)	
**2.	Part or Groups of items		
	i)	i)	months
	ii)	ii)	months
	iii)	iii)	months
5.	Defect Liability Period		
	General	03 years	
	Structural	05 years	
	Waterproofing	05 years	

Percentage to be charged as supervision charges for the work got executed through other means 10percent.

The “Actual cost of the work” shall mean in the case of percentage rate contracts the actual cost of the work executed at the rates as mentioned in the Contract Schedule adjusted by the Contractor's percentage rate and cost of extra and excess, but excluding the cost on account of Water Charges and Sewerage Charges if any, payable by the contractor and also excluding cost on account of price variation claims as provided in condition no. 74 of these conditions as amended up to date.

1. In case of item rate contracts the actual cost calculated for the work executed at the rates mentioned in the contract schedule for different items including cost of excess and extra items of the work excluding the cost of water charges and sewerage charges if any, payable by the contractor and excluding cost on account of price variation claims as provided in extra excess conditions as amended up to date.
2. In case of lump sum contract the cost of the work actually carried out as per break up and programme of the work and the schedule of payment included in the contract including cost of any excess and/or extra items, of the work, excluding the cost on account of water charges and sewerage charges and also excluding cost on account of price variation claims as provided in extra excess conditions as amended up to date.

ANNEXURE- B

On Rs. 500/- stamp paper

Bid No:

Name of Work:

PRE-CONTRACT INTEGRITY PACT

The Bidder commits himself to take all measures necessary to prevent corrupt practices, unfair means and illegal activities during any stage of his bid or during any pre-contract or post-contract stage in order to secure the contract or in furtherance to secure it and in particular commits himself to the following:-

1. The Bidder will not offer, directly or through intermediaries, any bribe, gift, consideration, reward, favour, any material or immaterial benefit or other advantage, commission, fees, brokerage or inducement to any official of the MCGM, connected directly or indirectly with the bidding process, or to any person, organization or third party related to the contract in exchange for any advantage in the bidding, evaluation, contracting and implementation of the Contract.
2. The Bidder further undertakes that he has not given, offered or promised to give, directly or indirectly any bribe, gift, consideration, reward, favour, any material or immaterial benefit or other advantage, commission, fees, brokerage or inducement to any official of the MCGM or otherwise in procuring the Contract or forbearing to do or having done any act in relation to the obtaining or execution of the Contract or any other Contract with the Government for showing or forbearing to show favour or disfavour to any person in relation to the Contract or any other Contract with the Government.
3. The Bidder will not collude with other parties interested in the contract to impair the transparency, fairness and progress of the bidding process, bid evaluation, contracting and implementation of the contract.
4. The Bidder will not accept any advantage in exchange for any corrupt practice, unfair means and illegal activities.
5. The Bidder, either while presenting the bid or during pre-contract negotiations or before signing the contract, shall disclose any payments he has made, is committed to or intends to make to officials of the MCGM or their family members, agents, brokers or any other intermediaries in connection with the contract and the details of services agreed upon for such payments.

6. The Bidder shall not use improperly, for purposes of competition or personal gain, or pass on to others, any information provided by the MCGM as part of the business relationship, regarding plans, technical proposals and business details, including information contained in any electronic data carrier. The Bidder also undertakes to exercise due and adequate care lest any such information is divulged.
7. The Bidder commits to refrain from giving any complaint directly or through any other manner without supporting it with full and verifiable facts.
8. The Bidder shall not instigate or cause to instigate any third person to commit any of the actions mentioned above.
9. The Bidder and their respective officers, employees, agents and advisers shall observe the highest standard of ethics during the Bidding Process. Notwithstanding anything to the contrary contained herein, the Authority may reject an Application without being liable in any manner whatsoever to the Applicant if it determines that the Applicant has, directly or indirectly or through an agent, engaged in corrupt practice, fraudulent practice, coercive practice, undesirable practice or restrictive practice in the Bidding Process
For the purposes of this Clause 9, the following terms shall have the meaning herein after respectively assigned to them:
 1. “fraudulent practice” means a misrepresentation or omission of facts or suppression of facts or disclosure of incomplete facts, in order to influence the Bidding Process ;
 2. “coercive practice” means impairing or harming or threatening to impair or harm, directly or indirectly, any person or property to influence any persons participation or action in the Bidding Process;
 3. “undesirable practice” means (i) establishing contact with any person connected with or employed or engaged by the Authority with the objective of canvassing, lobbying or in any manner influencing or attempting to influence the Bidding Process; or (ii) having a Conflict of Interest; and
 4. “restrictive practice” means forming a cartel or arriving at any understanding or arrangement among Applicants with the objective of restricting or manipulating a full and fair competition in the Bidding Process.

Signature of Tenderer/Bidder

Annexure-C

(This is a draft format)

(On Rs. 500/- Stamp paper)

DECLARATION CUM-INDEMNITY BOND

Bid No:

Name of Work:

I, _____ Of _____

do hereby declared and undertake as under.

1) I declared that I have submitted certificates as required to Executive Engineer (Monitoring) at the time of registration of my firm/ company _____ and there is no change in the contents of the certificates that are submitted at the time of registration.

2) I declared that I _____ in capacity as Manager/ Director / Partners / Proprietors of _____ has not been charged with any prohibitory and /or penal action such as demotion, suspension, black listing / de-registration or any other action under the law by any Government and/ or Semi Government and/ or Government Undertaking.

3) I declared that, I have perused and examined the tender document including addendum, condition of contract, specification, drawings, bill of quantity etc. forming part of tender and accordingly, I submit my offer to execute the work as per tender documents at the rates quoted by me in capacity as _____ of _____.

4) I further declared that if, I am allotted the work and I failed to carry out the allotted work in accordance with the terms and conditions and within the time

prescribed and MCGM is entitled to carry out the work allotted to me by any other means at my risk and cost, at any stage of the contract.

5)I also declared that I will not claim any charge / damages / compensation for non availability of site for the contract work at any time.

6)I Indemnify Municipal Commissioner and the other officers of MCGM or their agents for any Damages, Loss, or Injury, any legal suit, proceeding or legal action whatsoever that may be caused at any time by me or any other staff

of_____

company, for the work undertaken and all such damage, damages, injury or loss, legal suit, legal action, I shall be solely responsible in individual as well as official capacity and such loss, damages, injury shall be made good and/ or as the case may be shall be paid immediately by me / Company to the satisfaction of the MCGM.

Dated day_____ of , 20____

Identified by me,

Proprietor/Partners/Directors/POA holder
(Seal of Firm/Co.)

Advocate

Before me

Annexure- D

Bid No:

Name of Work:

Rate Analysis

Item Description

Sr. No.	Description of rate analysis parameter	Unit	Quantity	Rate	Amount
1	Basic Material (Rate should be inclusive of all taxes)				
2	Machinery Hire Charges				
3	Labour Type		(labour components)		
4	Total of all components				
5	Overhead & Profit 15% on 4				
6	Total Rate (4+5)				
7	Per unit rate				

Sign & Seal of the Tenderer

ANNEXURE – E

Tender No.

Bid No.:

GRIEVANCE REDRESSAL MECHANISM

Procuring Entity, M.C.G.M. has formed a Grievance Redressal Mechanism for redressal of grievances. Any Bidder or prospective Bidder aggrieved that any decision, action or omission of the procuring entity being contrary to the provisions of the tender or any rules or guidelines issued therein, may within a period of 7 days or any such other period, as may be specified in the pre-qualification document, bidder registration document or bidding documents make an application for review of such decision or action to procuring entity. While making such an application for review, aggrieved bidders or prospective bidders shall clearly specify the ground or grounds in respect of which he feels aggrieved.

Provided that after declaration of a bidder as a successful in Packet 'A' (General Requirements), an application for review may be filed only by a bidder who has participated in procurement proceedings and after declaration of successful bidder in Packet 'B' (Technical Bid), an application for review may be filed only by successful bidders of Packet 'A'. Provided further that, an application for review of the financial bid can be submitted, by the bidder whose technical bid is found to be acceptable /responsive.

Upon receipt of such application for review, M.C.G.M. may decide whether the bid process is required to be suspended pending disposal of such review. The M.C.G.M. after examining the application and the documents available to him, give such reliefs, as may be considered appropriate and communicate its decision to the Applicant and if required to other bidders or prospective bidders, as the case may be.

M.C.G.M. shall deal and dispose off such application as expeditiously as possible and in any case within 10 days from the date of receipt of such application or such other period as may be specified in prequalification document, bidder registration document or bid documents, as the case may be.

Where M.C.G.M. fails to dispose off the application within the specified period or if the bidder or prospective bidder feels aggrieved by the decision of the procuring entity, such bidder or prospective bidder may file an application for redressal before the 'Procurement Redressal Committee' within 7 days of the expiry of the allowed time or of the date of receipt of the decision, as the case may be. Every such application for redressal before Redressal Committee shall be accompanied by fee of Rs.25,000/-fee shall be paid in the form of D.D. in favour of M.C.G.M.

Procurement Redressal Committee will consist of not less than three members including its Chairman who shall be the DMC (GA) and two members of the Committee.

On receipt of the application, the Committee shall after giving opportunity of hearing to the procuring entity, M.C.G.M. as well as the Applicant, determine the issue taking into consideration the rules and guidelines as well as tender conditions, terms of the pre-qualification, bidder registration or bidding document, as the case may be and communicate its recommendations including corrective

measures to be taken to M.C.G.M. and to the Applicant within 10 days, if necessary, the Committee may held more sittings to dispose the application.

No application shall be maintainable before the Procuring Committee in regard of any decision of the M.C.G.M. relating to following issues:

- a) Determination of need of procurement
- b) The decision of whether or not to enter into negotiations.
- c) Cancellation of a procurement process for certain reasons.

The Procurement Redressal Committee may recommend to the procuring entity the suspension of the procurement process pending disposal of the application, if in its opinion, failure to do so, is likely to lead miscarriage of justice.

On receipt of recommendation of the Committee, Municipal Commissioner will communicate his decision thereon to the Applicant and to the Committee within 10 days or such further time not exceeding 20days, as may be considered necessary from the date of receipt of the recommendation and in case of non-acceptance of any recommendation, the reason of such non-acceptance shall also be mentioned in such communication.

Municipal Commissioner and/or Procurement Redressal Committee,if found, come to the conclusion that any such complaint or review is of vexatious, frivolous or malicious nature and submitted with the intention of delaying or defeating any procurement or causing loss to the procuring entity or any other bidder, then such complainant shall be punished with fine, which may extend to Five Lac rupees or two percent of the value of the procurement, whichever is higher.

Full Signature of the
Tendererwith
Official Seal and Address

BANKERS GURANTEE IN LIEU OF TENDER & CONTRACT DEPOSIT FOR

WORK

THIS INDENTURE made this _____ day of _____ BETWEEN
THE _____ BANK incorporated under the English/Indian Companies Acts
and carrying on business in Mumbai (hereinafter referred to as 'the bank' which
expression shall be deemed to include its successors and assigns)of the first
part _____
inhabitants carrying on business at _____ in Mumbai under
the style and name of Messer's _____(hereinafter referred to as 'the
contractors') of the second part Shri. _____
THE MUNICIPAL COMMISSIONER FOR GREATER MUMBAI (hereinafter referred to as
'the commissioner' which expression shall be deemed, also to include his successor or
successors for the time being in the said office of Municipal Commissioner) of the
third part and THE MUNICIPAL CORPORATION OF GREATER MUMBAI
(hereinafter referred to as 'the Corporation') of the fourth part WHEREAS the
contractors have submitted to the Commissioner tender for the execution of the work
of " _____and the terms of such
tender /contract require that the contractors shall deposit with the Commissioner as
earnest money and /or the security a sum of Rs. _____(Rupees
_____)AND WHEREAS if and when any such tender is accepted by the
Commissioner, the contract to be entered into in furtherance thereof by the
contractors will provide that such deposit shall remain with and be appropriated by
the Commissioner towards the Security -deposit to be taken under the contract and be
redeemable by contractors, if they shall duly and faithfully carry out the terms and
provisions of such contract and shall duly satisfy all claims properly chargeable
against them there under AND WHEREAS the contractors are constituents of the Bank
and in order to facilitate the keeping of the accounts of the contractors, the Bank with
the consent and concurrence of the contractors has requested the Commissioner to
accept the undertaking of the Bank hereinafter contained, in place of the contractors
depositing with the Commissioner the said sum as earnest money and /or security as
aforesaid AND WHEREAS accordingly the Commissioner has agreed to accept such
undertaking NOW THIS AGREEMENT WITNESSES that in consideration of the
premises, the Bank at the request of the contractors (hereby testified) UNDERTAKES
WITH the commissioner to pay to the commissioner upon demand in writing ,
whenever required by him , from time to time , so to
do _____,a sum not exceeding in the whole

Rs. _____ (Rupees _____) under the terms of the said tender and /or the contract .The B.G. Is valid upto _____”Notwithstanding anything what has been stated above, our liability under the above guarantee is restricted to Rs. _____ only and guarantee shall remain in force upto _____ unless the demand or claim under this guarantee is made on us in writing on or before _____ all your right under the above guarantee shall be forfeited and we shall be released from all liabilities under the guarantee thereafter”

IN WITNESS WHEREOF

WITNESS(1) _____

Name and _____

address _____

WITNESS(2) _____

Name and _____

the duly constituted Attorney Manager

address _____

the Bank and the said Messer’s _____

(Name of the Bank)

WITNESS(1) _____

Name and _____

address _____

WITNESS(2) _____

Name and _____

For Messer’s _____

address _____

have here into set their respective hands the day and year first above written.

The amount shall be inserted by the Guarantor, representing the Contract Deposit in Indian Rupees.

PROFORMAS

PROFORMA – I

The list of similar works as stated in Para ‘A’ of Post qualification during last seven years–

PROFORMA – I												
Sr. No	Name of the Project	Name of the Employer	Date of starting of work	Stipulated/ Actual Date of Completion	Actual cost of work done in Rs. (year-wise)							
					08-09	09-10	10-11	11-12	12-13	13-14	14-15	Total
1												
2												
3												

NOTE:

1. Scanned Attested copies of completion/performance certificates from the Engineer-in-Charge for each work should be annexed in the support of information furnished in the above proforma.
2. Works shall be grouped financial year-wise.

PROFORMA – II

Yearly turnover of Civil Engineering Construction Works during the last five years.

PROFORMA – II					
Sr. No.	Financial Year	Annual Turnover of Civil Engineering Works	Updated value to current year	Maximum of last 5 years	Page No.
1					
2					
3					
		Total			

NOTE: The above figures shall tally with the audited balance sheets uploaded by the tenderers duly certified by Chartered Accountant.

PROFORMA- III

Atleast similar work, as stated in para 'A' of Post qualification,

PROFORMAIII							
Name of the Project	Name of the Employer	Cost of the Project	Date of is-sue of work Order	Stipulated Date of Completion	Actual Date of Completion	Actual cost of work done	Remarks explaining reasons for delay, if any
1	2	3	4	5	6	7	8

PROFORMA – IV (PERSONNEL)

PROFORMA – IV					
Sr. No.	Post	Name	Qualification	Work Experience	
		(Prime Candidate/ Alternate)		No. of Years	Name of Projects
1					
2					
3					
4					

NOTE: Scanned Attested copies of qualification certificates and details of work experience shall be submitted/uploaded.

PROFORMA V/A (MACHINERY)

PROFORMA V / A				
Sr. No.	Equipment	No.	Owned / Leased / Assured Access	Documents at Page
1	2	3	4	5

PROFORMA V/B

PROFORMA V / B				
Sr. No.	Equipment	No	Owned	Documents at Page
1	2	3	4	5

Note: The tenderer(s) shall furnish/upload the requisite Scanned Attested documents of ownership/leased of machineries. The undertaking from the suppliers will not be accepted.

PROFORMA - VI/A

PROFORMA VI/A							
Description of work	Place	Contract No. & Date	Name & Addresses of employer	Value of Contract in Rs.	Scheduled date of completion	Value of work remaining to be completed	Anticipated date of completion
1	2	3	4	5	6	7	8

Details of Existing Commitments and ongoing works –

Note: Scanned Attested copies of completion/performance certificates from the Engineer-in-Charge for each work should be annexed in the support of information furnished in the above proforma.

PROFORMA - VI/B

Details of works for which bids are already uploaded –

PROFORMA VI/B						
Description of work	Place	Name & Addresses of employer	Value of Contract in Rs.	Time Period	Date on which decision is expected	Remarks
1	2	3	4	5	6	7

Note: Scanned Attested copies of certificates from the Engineer-in-charge for each work shall be annexed.

Annexure-A
Irrevocable Undertaking

(onRs. 500/- Stamp paper)

Bid No:

Name of Work:

IShri/Smt.....aged,.....years IndianInhabitant.
Proprietor/ Partner/Director of M/SResident at
.....do hereby give Irrevocable undertaking as under

1. I say & undertake as specified in section 171 of CGST Act, 2017 any reduction in rate of tax on supply of goods or services or the benefit of input tax credit shall be mandatorily passed on to MCGM by way of commensurate reduction in prices.
2. I further say and undertake that I understand that in case the same is not passed on and is discovered at any later stage, MCGM shall be at liberty to initiate legal action against me for its recovery including, but not limited to, an appeal to the Screening Committee of the GST Counsel.
3. I say that above said irrevocable undertaking is binding upon me/my partners/company/other Directors of the company and also upon my/ our legal heirs, assignee, Executor, administrator etc.
4. If I fail to compliance with the provisions of the GST Act, I shall be liable for penalty/punishment or both as per the provision of GST Act.

Whatever has been stated here in above is true & correct to my/our own knowledge & belief.

Solemnly affirmed at

DEPONANT

This day of

BEFORE ME

Interpreted Explained and Identified by me