



BRIHANMUMBAI MAHANAGARPALIKA

Section 4 Manuals as per provision of
RTI Act 2005 of **K/East** Ward

ASSTT. ENGINEER(MAINT.) DEPARTMENT

Address - Office of Asstt. Engineer (Maint),
**1st Floor, K/East Ward Building,
Gundavali village, Azad road
Mumbai-400012**

INDEX

©	Section 4 (1) B Sub Clauses	Description of the Chapter's Contents	Page No.
		Introduction	3 – 4
1	4 (1) (b) (i)	Particulars of Organization, Function and Duties	5 - 21
2	4 (1) (b) (ii)	Powers and Duties of Officers and Employees	22 – 49
3	4 (1) (b) (iii)	Procedure followed in Decision Making Process including Channels of supervision and accountability	50 – 58
4	4 (1) (b) (iv)	Norms set for discharge of its functions	59
5	4 (1) (b) (v)	The rules, regulation, instruction, manuals and records, held by it or under its control or used by the employees for discharging department functions	60
6	4 (1) (b) (vi)	Statement of categories of documents that are held and under the control of the office of Asstt. Engineer (M & R)	61 – 62
7	4 (1) (b) (vii)	Particulars of any arrangement that exists for consultation with the members of the public in relation to the formulation of the department's policy and implementation thereof.	63
8	4 (1) (b) (viii)	A Statement of the boards, councils, committees and other bodies consisting of two or more persons constituted as its part or far the purpose of its advice, and as to whether meetings of those boards, councils, committees and other bodies are open to the public or the minutes of such meetings are accessible for public.	64
9	4 (1) (b) (ix)	Directory of the officers and employees	65 – 74
10	4 (1) (b) (x)	The monthly remuneration received by each of its officers and employees including the system of compensation as provided in its regulations.	75 – 100
11	4 (1) (b) (xi)	The Budget allocated to each of its agency, indicating the particulars of all plans, proposed expenditures and reports on disbursement made.	101 – 103
12	4 (1) (b) (xii)	The manner of execution of subsidy programs, including the amounts allocated and the details of beneficiaries of such programs.	104
13	4 (1) (b) (xiii)	The particulars of recipients of concession, permits or authorisations granted by department.	105
14	4 (1) (b) (xiv)	Details in respect of the information available to or held by it, reduced in an electronic form.	106
15	4 (1) (b) (xv)	The particulars of facilities available to citizens for obtaining information including the working hours of a library or reading room	107
16	4 (1) (b) (xvi)	The names, designations and other particulars of the Public Information Officers	108 – 110
17	4 (1) (b) (xvii)	Such other information as may be prescribed.	111 - 118

Introduction

Assistant Engineer (Maintenance & Repair)

The right to information is implicitly guaranteed by the Constitution. However, with a view to set out a practical regime for securing information, the Indian Parliament enacted the Right to Information Act, 2005 and thus provided a powerful tool to the citizens to get information from the Government as a matter of right. This law is very comprehensive and covers almost all matters of governance and has the widest possible reach, being applicable to Government at all levels- Union, State and Local as well as recipients of government grants.

The basic object of the Right to Information Act is to empower the citizens, promote transparency and accountability in the working of the Government and make our democracy work for the people in real sense. The Act is a big step towards making the citizens informed about the activities of the Government.

The Act requires the Government authority to compile a handbook in easily comprehensible form and to update it from time to time under **Section 4(1) b** sub clauses i to xvii (17 Manuals). The objective of publishing 17 Manuals is the proactive disclosure of the information/records held by Govt. Authority for the information seekers. The office of Assistant Engineer, Maintenance & repair, **K/East ward** is hereby publishing the Handbook for 17 Manuals as required under RTI Act 2005 to promote transparency and accountability in the working of the department & to give easy access to the information seekers to the information & records held by this office.

This handbook contains introduction about the department along with particulars of its functions, duties, objectives & vision. It further elaborates about the duties, powers delegated to its officers & employees. The procedure followed in decision-making process, accountability of concerned officers, norms set for discharge of its function along with Acts, related rules/regulations are further described in detail. It also contains the Statement of Categories of documents held by this office, directory & remuneration of its officers and employees. The details of budget allocation & its disbursement, particulars of permits issued, facilities available for citizens & details of PIO/Appellate authority is also published for information.

This consolidated updated handbook on 17 Manuals of the Act would help all the information seekers in getting information. However, in case any information seeker wants to get more information on topics covered in the handbook as well as other information may contact Assistant Engineer (Maintenance & repair), K/East ward whose office is situated at K/East ward office, **1st Floor, K/East Ward Building, Gundavali village, Azad road Mumbai-400012**. The procedure and

fee structure for getting information is as per the provisions of RTI Act, 2005.

The Municipal Corporation of Greater Mumbai has decentralized most of the main departments and placed the relevant sections of these departments under the Assistant Commissioner at ward level. Maintenance department is an important department in the Ward Office and it is operated by the Sub Engineers and Junior Engineers working under the Assistant Engineer (Maintenance & Repair) is under administrative control of Assistant Commissioner. The Assistant Engineer (Maintenance & Repair) is the sectional Head of Ward who is responsible for the maintenance & repairs of Municipal roads & properties with the help of departmental artisans and approved private contractors. He has to take appropriate action on the unauthorized constructions detected on Roads & footpaths. This department issues various permissions like Mandap Permission, Trench permission, **shooting permission** etc. as per various norms.

Beat wise responsibility of the electrol wards rests with the Jr. Engineers. The Jr. Engineers works under the supervision of the Sub Engineer & the control of Assistant Engineer. **Road engineer/sub engg is responsible for upkeep maintenance of major & minor roads and road engineer/sub engineer is responsible for overall maintenance and safe guarding the site of stolen man hole cover, surrounding portion of manhole and lodging complaint/F.I.R Inco-ordination with police authority for vigilance and look out for suspected miscreants with the help of local resident.** The preview of this department is quite extensive and the staff such as Mukadam & Labours in Roads & Repair sections, Mistry, Carpenter, Mason, Blacksmith, Plumber etc work in this department. Material required for the various departmental works is provided by Store Clerk.

As per Central Right to Information Act 2005, designated officer is appointed as Public Information Officer Maintenance & Repair for Maintenance & Repair department and as per Maharashtra Public Records Act-2005 and Maharashtra Public Records Act Rules -2007, he is designated as Record Officer for Maintenance & Repair Dept.

**Assistant Engineer (M & R)
K/East ward**

SECTION 4 (1) (b) (i)

The particulars of functions & duties of the public authority

1	Name of the Section	Office of Assistant Engineer (Maintenance & Repair)
2	Address	1st Floor, K/East Ward Building, Gundavali village, Azad road Mumbai-400012
3	Head of the office	Assistant Engineer, Maintenance & Repair
4	Office Timings	Monday to Friday 8.00 a.m. to 12.00 noon and 2.30 P.M. to 5.30 p.m. Saturdays 08.00am to 11.30 am Visiting Hours - (Monday – Friday) 03.00 p.m. to 05.00 pm Holidays- Sunday & Public Holidays
5	Chowky Timings	07:30 am – 2:30 pm
6	Contact Details	Telephone no : 26840986 Extn : 328(AEM—I) & 325(AEM-II). Email Asst. Eng - ae01me.kem@mcgm.gov.in ae02me.kem@mcgm.gov.in
7	Parent Government Department	City Engineer
8	Reporting to which office	Assistant Commissioner, K/East ward Ward Ex. Engineer, K/East ward
9	Jurisdiction Geographical	K/East ward is bounded by the Mithi river on the East, western railway on West, S.R.P.F ground on North and Milan subway on South side in Western suburb business hub comprising of M.I.D.C
10	Vision	<ol style="list-style-type: none"> 1. Well maintained Roads 2. Well maintained Municipal Properties 3. Easy traffic movement during peak hours as Times of India has declared the second number major floating population dropped at Andheri station from various locations of Mumbai during peak hours. Considering these requirements M.M.R.D.A had commissioned 1st METRO ONE project connecting

		Western suburb to Eastern suburb and planning to commission Metro 3 project from Seepz to Colaba. Considering future development upkeep surrounding roads for easy access towards various Metro station.
11	Mission	<ol style="list-style-type: none"> 1. To Repair & Maintain Minor Roads, Footpath & Municipal Properties, J.V.L.R widening, Mithi river, water main, development of Mogra system, decongestion of Jogeshwari (E) station 2. Connectivity of Andheri (W) and Andheri (E) by removing bottleneck of Nicholaswadi road and improving 27.3 m wide R.K Singh road forming connectivity to Jogeshwari (E) and Andheri (E) railway station parallel link to Western express highway upto Goregaon-Mulund link road. 3. Demolition or repairing of dilapidated Municipal buildings in K/E ward.
12	Objectives	To Repair & Maintain Roads and Footpath & Municipal Properties.
13	Functions	<ol style="list-style-type: none"> (a) Repair & Maintenance of Minor Roads & Footpath in Ward. (b) Repair & Maintenance of Municipal Properties in purview of the Estate Department. (c) To demolish the unauthorized encroachments on footpath, roads & Municipal Plots. (d) Issuance permits to the excavation of trenches on roads to the various utility services & various departments of MCGM. (e) Granting of Mandap Permission for social & regional purpose on Roads, Footpath & Municipal Properties. (f) Reinstatement of trenches and upkeep maintainance of major and minor roads (g) Detection of dilapidated building and prepare

		<p style="color: red;">upkeep list of Municipal properties</p> <p>(h) Granting of Ganapati Mandap Permission on Roads, Footpath & Municipal Properties.</p> <p>(i) Granting of Film shooting permission on Municipal Roads.</p> <p>(j) Improve roads under Section 63 (K) of MMC Act. (refer pg. no. __) and improve private layout roads as per recommendation of Prakash Mehta Committee under 306 of MMC act by improving road under 63k of MMC act by utilizing 1/3 rd grant of Municipal councillor / M.L.A & M.P. and 2/3 rd grant from Municipal budget.</p> <p>(k) Acquire the Setback area of the road & merge the same into the road by following recent circular of MRTP act by removing authorized structures (refer pg. no. __)</p> <p>(l) Removal of Bottlenecks by following guidelines as per bottleneck policy . (refer pg. no. __)</p> <p>(m) Action in respect of dangerous Municipal buildings for following recent guidelines.</p>
14	Details of Services provided (In Brief)	<p>1. Trench Permission : -</p> <ul style="list-style-type: none"> • Issuance of permits for the excavation of trenches on roads to various utility Services & Various departments of MCGM is granted as per Trench Guideline Circular Policy issued by Municipal Commissioner u/no. MGC / F/1835 dated 17.11.2007. (attached) and

various recent circular

- Permission for laying augmentation of the utility pipelines / cables shall be granted only during the fair season starting from 1st October till 30th April. For trench exclusively on footpath / paver blocks, the permission shall be granted upto 30th April.
- From 16th April to 30th September, for the fault repair, sanction of Zonal D.M.C. shall be obtained as far as possible before undertaking excavation.
- As per recent circular vide no. MGC/F/9974 dated 04.02.2013

2. Issuance of Ganpati Mandap Permission is granted as per Circular u/no MDF / OD / 8358/Gen dt. 11.06.2013.

3. Issuance of Film Shooting permission.

4. Bottleneck :-

- Bottleneck means construction, narrowing, obstruction, congestion, block, partially/total blockage which leads to traffic congestion, traffic clogging problems started due to precipitant.
- Reference Circular – AMC/ES/D/168 (ChE/1876/DPC/Gen) Dated 25.02.2004.
- Recently we are using MRTP 56 clause.(Power to require removal of authorized development or use.)

		<ul style="list-style-type: none">• (AMC/ES/9141 dt. 14.10.2011. <p>5. 63 K Road :-</p> <ul style="list-style-type: none">• Arising out of representation from residents of private layouts and Public representatives, that layout residents are paying Municipal taxes and therefore roads should be maintained by MCGM.• Reference Circular ChE/1484/Roads Dated 16.05.2009<ul style="list-style-type: none">(i) As per the circular 1/3 cost of up gradation shall be borne by Co. Op. Hsg. Society of Residents, 2/3 cost by MCGM and the private street shall be declared public under section 306 of MMC Act 1888 before taking up the works. However, in case 1/3 construction cost is not deposited by Co. Op. Hsg. Society / Federation of Societies and roads in private layout are to be improved using Municipal Funds, M.P./MLA funds then sanction under section 63 K(ii) As per old circular u/no.CE/7651/Roads of 12.08.1976 and CE/12162/Roads/VI of 09.04.1979 for declaring road under 63 k of M.M.C act.
--	--	--

6. Departmental Maintenance & Repair :-

- Beat wise responsibility of the electrol wards rests with the Junior Engineers. The Junior Engineers works under the supervision of the Sub Engineer and the control of Asstt. Engineer. The Junior Engineer reports to his chowky along with his workmen at 7.30 a.m. the labour distribution is carried out after singing the muster at 7.30 a.m.
- A group of workmen (gang) comprising of 2 to 3 labours, the skilled labours such as mason, carpenter and plumber is formed and additional labours as per the extent of job is provided to that gang. A job Slip is issued to gang to carryout various day to day work. The job Slip is prepared by the Junior Engineer according to nature and priority of complaint and it is signed by Mistry and the Junior Engineer. The address of Municipal property where the work is to be carried out, nature of work and the number of workmen is mentioned in the job slip.
- Up keep maintenance of road repair work and reinstatement of trenches by RE/Sub engineer.
- Generally, sufficient material is brought to the chowkies from the Central Store. The non-scheduled items are also procured by following due procedures or by calling for the quotations, from the open market. The material thus procured is stocked in the store and is in position with supervision / clerk. This material is transported to the work site in Municipal vehicles.

- Junior Engineers, Mistry / Mukadam visit the work site, at least once, for supervision and guidance. The Junior Engineer reports to the office to attend the office work in the afternoon session between 2.300 p.m. to 5.30 p.m

7. E-Tendering :-

- Preparation of Estimate by J.E.
- Obtain Administrative approval from ward Committee or DMC etc.
- Estimate is uploaded in SAP System in A.E. or SE's ID (R3 Module)
- BID is **created by S.E. using** his/her ID. SRM Module E tendering.
- BID is forwarded to E.E. Ward for publishing on Municipal Website.
- Ward E.E. Publish the Tender (SRM E tender login Approval)
- List of Bidder and letter to successful 1st Bidder with 5 % contract amount to deposit with MCGM
- PO is created by A.E. in SAP Module.
- Release P.O. Amount by A.O.
- Create Contract by E.E. ward in SAP System.
- PO is generated by A.E. in SAP and released by E.E. Ward.
- PO printout is taken by AE and issued to Bidder.

		<p>8. CWC contractor, trench contractor, premonsoon , upkeep maintenance work and desilting/desludging work</p> <p>9. Mahatma Gandhi Pathkranti Yojana:-</p> <ul style="list-style-type: none"> • It is a scheme to clear the footpath of encroachment. • Certain roads are identified in each ward. • Cutoff date is 01.01.1995 / 01.01.2000. • The eligible hutment dwellers are offered alternate accommodation. • To draw lottery to decide alternate accommodation in presence of all eligible hutments dwellers. • After shifting mass demolition to be carried out. • The footpath so cleared should be immediately developed for public usage. • AMC/ES/944/IV dated 31.03.2012 • DMC/RE/Z.Su/4274 dated 26.02.2013. <p>10. Clearance of encroachment along water main</p> <p>11. Decongestion of railway station</p> <p>12. Conversion of Zhunka bhakar Kendra into Annadatta Kendra</p>
15	Physical assets (Statement of lands & Buildings and other	As per separate sheet attached (Page No.____)

	Assets)	
16	Organization's structural Chart	As per separate sheet attached (Page No.____)

Details of Departmental Chowky in Asstt. Engineer (Maint) Section

Sr. No.	Type	Name of Chowky	Address of Chowky	Contact no.
1.	Road & Repair	Swami Nityanand chowky	Near Gokhale Bridge Sahar Rd. Andheri (E) Mumbai 400 069	
2.	Road & Repair	Gundavali Municipalchowky	Gundavali Western Express highway Andheri (E) Mumbai 400 069	
3.	Repair	Jogeshwari Muncipal chowky	Dheeraj Apt Western Express highway Andheri (E) Mumbai 400 069	
4.	Repair	MIDC Munciapal chowky	Acma Plaza bldg. No. 2 Andheri -Kurla Rd. Mumbai 400 92	

Physical Assets of Asst. Engineer (Maintenance) K/East Ward

Sr. No.	Beat No.	Name & Address	Floor	Remark
1.	66	Sarswati Baug Municipal school, Sosa Rd. Jogeshwari (E) Mumbai-400 060	Gr+3	
2.	66	Natwar Nagar Municipal school, Rd. no.05 Society Rd. Natwar Nagar Jogeshwari (E) Mumbai-400 060	Gr+5	
3.	66	Natwar Nagar dispensary, Natwar nagar Rd. No. 5 , Jogeshwari	G	
4.	66	Ajgaonkar Health Post, Jaicoach, Jogeshwari	G	

5.	66	Bandrekarwadi School, Jaicoach, Jogeshwari	G	Demolish
6.	66	Thakur School, R.K. Singh Road, Jog.	G+5	
7.	66	Asmita Garden, Jaicoach , Jogeshwari	G	
8.	66	Rajaram garden, Gumpha Road , Jogeshwarl	G	
9.	66	Nawalkar Market, Jogeshwari	G	
10.	67	Pratap Nagar Hindu Cemetry, J.V.L.Road	Ground	
11.	67	Plot reserved for Public amenity Centre , J.V.L.Rd , Near Brookhaven Bldg.	G	
12.	67	Sherwala Mun.school Near Nemani Bridge Jogeshwari Gumpha Rd	4	Demolish
13.	68	Shri. Vijay salaskar Udyan, J.V.L.Road	Garden	
14.	68	Shri. Ashok Kamte Udyan, Poonam Nagar	Garden	
15.	68	Shivaji Municipal Ground, S.V.P. road	Open Ground + G+1 Structure	
16.	68	Matoshri Club, J.V.L.Road	G+2 Structure	
17.	68	Vachnalay Near Pimpleshwar Mahadeo Mandir	Grond structure	
18.	69	Municipal Ground (P.g.)inside vastu complex, manish park,Andhari.	Ground floor	
19.	69	Play Ground opp. Satya saibaba mandir,mahakali caves road ,Andheri(E)	G	
20.	69	Veravali municipal school,mahakali caves road,Andheri(E).	Ground floor	
21.	69	East mogra municipal school,Jijamata road,Andheri(E).	Ground floor	
22.	69	Municipal clinic,sarvodya nagar,Jogeshwari(E).	Ground floor	
23.	69	Koliwada mun. school ,W.E. Highway, Jogeshwari(E)	G + 4	
24.	70	Harinagar urdu mun. school,Harinagar,Jogeshwari(E)	G + 4	
25.	70	Shankarwadi mun,school,Hari nagar, Jogeshwari(E)	G + 3	
26.	70	Meghwadi mun. school,Amina nagar, Jogeshwari(E)	Ground	
27.	70	Gumpha road mun. school,Gandhi nagar, Jogeshwari(E)	G + 4	
28.	70	Squatter colony maternity home,sanjay Gandhi nagar,	G + 6	

		Jogeshwari(E)		
29.	70	Zula maidan ,kulaba plot, Jogeshwari(E)	G	
30.	70	Janata Market Prem nagar Jogeshwari(E)	G	
31.	71	Mogra pada mun urdu school	G	
32.	72	Green wood society S.W.D. office of Western suburban ,Andheri Kurla road ,Andheri(E)	G+1	
33.	72	CTS No. 242 of Govindwadi Talao, Govindwadi, Andheri(E).	Ground	
34.	72	Malpa dongri municipal school, Malpa Dongri no. 03, Andheri(E)	G+1	
35.	72	Municipal dispensary at Evrest ground ,near shanti nagar, Mahakali caves road ,Andheri(E)	Ground	
36.	72	Municipal Market , floor dec plaza, road No.23, Near subhash nagar	Grond floor	
37.	72	R.G. Plot , B-cross road , MIDC	G	
38.	73	Maheshwari garden Plot, maheshwari Nagar, YAC Toad, Kondivita	G	
39.	73	Accommodation reservation bldg., Proctor & Gamble , C.G. road, Chakala	G+2	
40.	73	Accommodation Reservation Bldg. , Kankiya spaces, (Courtyard Marriot Hotel), A.K.Road, Chakala	G+1	
41.	73	Accommodation Reservation Bldg., Beside Rashtriya Metal, A.K.Road	G+2	
42.	73	RG plot at padma Nagar, Chakala, Beside Jain Temple	G	
43.	73	Accommodation Reservation Bldg., Beside Kondivita Road	G+2	
44.	73	A.E.(Env) Chowky, Subhash Nagar, In front of ICICI , Road No.23	G+1	
45.	73	Reservation plot at Perera Hill Road	G	
46.	73	Municipal dispensary at sunder nagar, Mahakali caves road ,Andheri(E)	Ground floor	
47.	74	Marol Maternity Home, Marol Gaon Road	G + 5	

48.	74	Municipal dispensary at Church road	Ground	
49.	74	A.E.(Env) Chowky, Church Road	Ground	
50.	74	Municipal Marol Market , Church road	Ground	
51.	74	CTS No. 1189, garden Plot, Behind Mun Dispensary, Church Road	G	
52.	74	CTS. 1296, Bori Colony, Play Ground, Church road	G	
53.	74	Marol Store, HE dept., Beside Marol Bus Depot	Ground	
54.	74	Municipal Staff Quarters, H.E. Dept, Beside Marol Maroshi Bus Stand	G + 2	
55.	74	Marol Fire Brigade , M.M. Road	A) G+M+11/2 B) 7 No = G + 4 C) Adm = G + 2	
56.	74	Mun. Hindi School, Hanuman Road, Marol gaon	Ground	
57.	74	CTS No. 1386, Library Bldg., A-Cropolise Building, Hill Top Lane, Marol Off Church Road Run by Bharat Vikas Manch	G	
58.	74	CTs No. 138/9, 138/10, 138/11 , Parking Lot, D.P. road Off Military road	G	
59.	74	CTS No. 132 , AKD , Bharat Van, bamandaya Pada, Military Road	G	
60.	74	CTS no. 135/B , Bamandaya Pada, Beside Dispensary	G	
61.	74	Municipal Police Camp School, Police camp, Marol Maroshi Road	Ground	
62.	74	Staff Quarters , Pipe Line, saibaba Nagar(H.E.) Dept, Marol	Ground	
63.	75	Sagbaug Municipal school	Ground	
64.	75	Sagbaug Cemetry A.K.Rd.Mithi Nadi Andheri (E)	Ground	
65.	75	Ruby Coach Garden	G	
66.	75	Sahar Gaon garden	G	
67.	75	Lokbharti Garden ,	G	
68.	75	Kuntipark garden , Marol Maroshi Road	G	

69.	75	Satbaug Pumping Station	G + 1	
70.	76	Chakala Mun School	Ground & G+4	
71.	76	Tarun Bharat Health Post	Ground	
72.	76	Mother Teressa Islampura garden, CTS No. 398	Ground	
73.	76	J.B. Nagar Market	G+2	
74.	76	R.G. Plot of Village Kondivita , CTS No. 443/B At Bagdaka Road	G	
75.	76	P.G. Plot CTS No. 431/A At Misry Complex Road	Ground	
76.	76	R.G. CTS No. 271 of Village Kondivita	G	
77.	76	Marol Fish Market	Ground	
78.	76	P.G. Plot at CTS No. 131/A/1/E, andheri Ghatkopar Link Road, Village Chakala	G	
79.	76	R.G. CTS No. 131/A/1/D , Andheri Ghatkopar Link Road	Ground	
80.	76	State Central Library , Digital Sub-centre, CTS No. 13/A/1/C	G+3	
81.	77	Parsipada Hindu cemetry	Ground floor	
82.	78	Municipal K / East Ward office, Gundavali	G + 4	
83.	78	Telli Gully Mun. Schhol	G+2	
84.	78	Gundavali municipal School	G+4	
85.	78	RadhaKrishna Municipal School	G+2	
86.	78	OLD Nagardas road market	G+2	
87.	78	Koldongri Dispensary	Gr Floor	
88.	78	Nityanad School, sahar Road	G + 2	
89.	78	SWM , PCO , Masint Chowky below Gokhle Bridge	Ground	
90.	78	Gundavali Chowky	Ground	
91.	79	Sambhyaji Nagr Mun. Dispensary, sambhaji Nagar	Ground	
92.	79	Shahaji raje Health Post and Ayurvedic Dispensary, shahaji raje Road	2 Nos. Ground storyed	
93.	79	Shahaji Raje Municipal school, Shahaji Raje Road	G+4	

94.	79	Sambhaji Nagar Municipal School, Sambhaji Nagar	Ground	
95.	79	Shirodkar Maternity Home, Subhash road	G 3	
96.	79	Swatantra Veer sawarkar kendra, M.G. Road	Ground	
97.	79	Swatantra Veer sawarkar Udyan, M.G. Road	Security Cabin	
98.	79	Adhar Kendra , Babasaheb Gawde Hospital	G	
99.	79	M.G. road Mun School, M.G. road	Partly G + 2 & partly G+3	
100	79	Dinanath Natyagraha and Municipal Market, V.S. Khandekar Marg	G + 2	
101	79	Anandibai Keskar Udyan, M.G. Road	Ground	
102	79	Water work Dept., Quarters, M.G. Road	G + 3	
103	79	Municipal Chowky samartha Krupa Bldg., Ram Mandir Road	Ground	
104	79	Hedgewar Maidan, Hanuman Road	Ground	
105	79	Municipal Conservancy Chowky, Parleshwar & V.S.Khandekar Road Jun.	Ground	
106	79	Shahaji Raje Play Ground	Ground	
107	79	Prabhodankar Thackeray Udyan, Shahaji Raje Road	Ground	
108	79	Amenitr open space sahakar road , Villeparle (E)	Open Plot	
109	80	Municipal Conservancy Chowky, Shradhanand Road	Ground	
110	80	Conservancy Staff Quarter, shradhanand Road	Ground + 6	
111	80	48 Tenaments , for house for dishouse,, Shradhanand Road	Ground + 5	
112	80	Municipal office, Nehru Road Villeparle (E)	Ground + 5	
113	80	Dubashi Garden, Gujort society Road Villeparle (E)	Ground	
114	80	Sathe Udyan, Malviya Road Villeparle (E)	Ground	
115	80	R.G. Plot , F.P. No. 108/109, service Road Villeparle (E)	G	
116	80	Garden at Milan subway Villeparle (E)	Ground + 1	
117	80	Nana Nani Park, Dayaldas Road Villeparle (E)	Ground	

**Organization structural Chart of office of Assistant Engineer (Maintenance)
K/East ward**

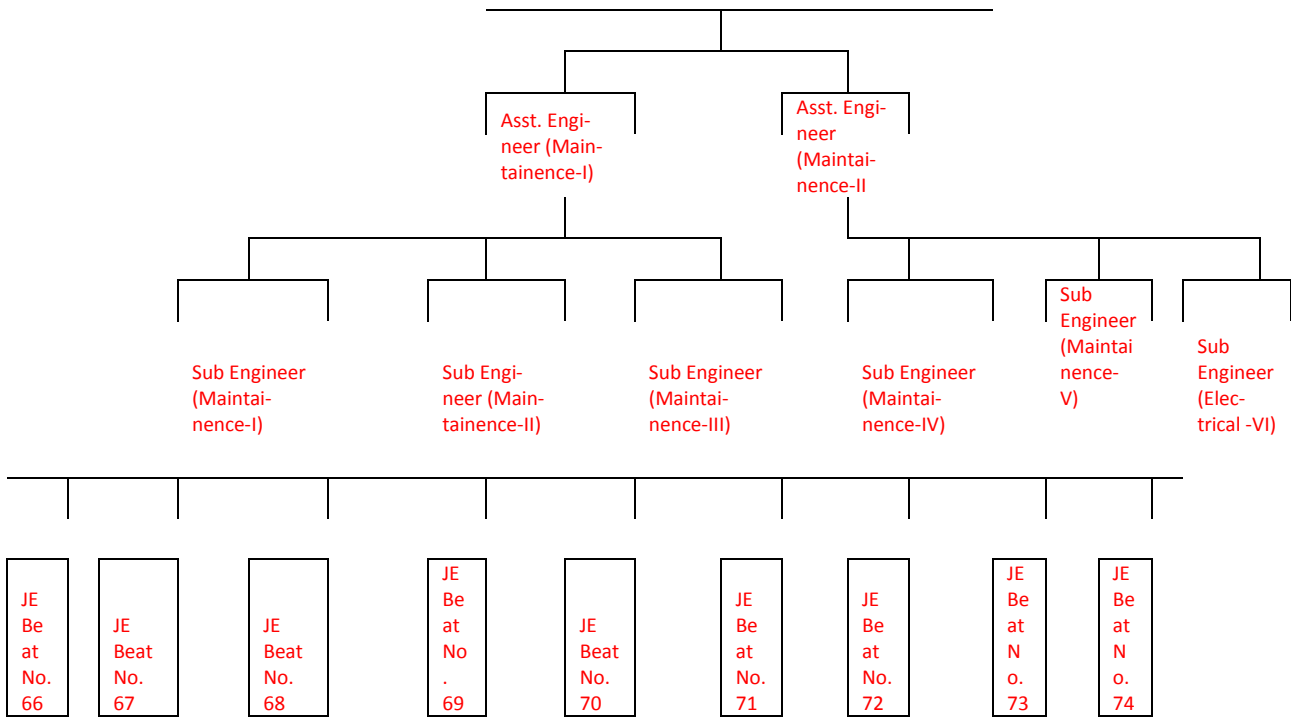

Store clerk
F-1

designa- tion	RD Roll er Driv er	Mi- stry	Painter	Ma so n	Car- pen- ter	Mu- ka- dam	La- bours	Ha ma l	Bhis ti III
F-1	3	4	2	4	1	12	219	3	1

Department- Asst. Engineer (Maint)

Sr No	Post	Schedule Post	Occupied	Vacant
1	Asstt. Engineer	2	2	Nil
2	Sub. Engineer	6	6	Nil
3	Jr. Engineer	15	15	Nil
4	Store Clerk	1	1	Nil
5	Labourer	273	219	54
6	Mistry II	4	4	Nil
7	Mason II	4	1	3
8	Mukadam	26	12	14
9	Carpenter II	1	Nil	1
10	Painter III	1	1	Nil
11	Painter II	1	1	Nil
12	Labourer C Watchman	15	10	5
13	Liftman C Wirmen C Plumber	2	2	Nil
14	Hamal	3	3	Nil
15	Bhisti III	1	Nil	1
16	Road Roller Driver	3	Nil	3

SECTION 4(1)(b) (ii)

The powers of offices and employees in the office of Assistant Engineer (Maint)

A-Financial Powers

Sr. No.	Designation	Powers - financial	Under which legislation/rules/orders/GRs	Remarks
1	Assistant Engineer (Maintenance)	Rs.3000/-	AS per the circular no CA/FRD/I48 dated 31.01.2013	
		Rs.3,00,000/-	---	To scrutiny of Estimate
2	Sub Engineer (Maintenance)	Nil	N.A.	
3	Junior Engineer (Maintenance)	Nil	N.A.	

SECTION 4(1)(b) (ii)

The powers of offices and employees in the office of Assistant Engineer (Maint)

B-Administrative Powers

Sr. No.	Designation	Powers – Administrative	Under which legislation/rules/orders/GRs	Remarks
1	Assistant Engineer (Maintenance)	Please refer to Delegation of powers to Asst.Engineer (Pg. no.____)	1. MMC Act 1888 2. MRTP Act1966	

2	Sub Engineer (Maintenance)	Please refer to Delegation of powers to Sub Engineer (Pg. no.____)	1. MMC Act 1888 2. MRTP Act1966	
3	Junior Engineer (Maintenance)	Please refer to Delegation of powers to Junior .Engineer (Pg. no.____)	1. MMC Act 1888 2. MRTP Act1966	

SECTION 4(1)(b) (ii)

The powers of offices and employees in the office of Assistant Engineer (Maint)

C-Magisterial Powers

Sr. No.	Designation	Powers – Magisterial	Under which legislation/rules/orders/GRs	Remarks
1	Assistant Engineer (Maintenance)	Nil	N.A.	
2	Sub Engineer (Maintenance)	Nil	N.A.	
3	Junior Engineer (Maintenance)	Nil	N.A.	

SECTION 4(1)(b) (ii)

The powers of offices and employees in the office of Assistant Engineer (Maint)

D-Quasi Judicial Powers

Sr. No.	Designation	Powers – Quasi Judicial	Under which legislation/rules/orders/GRs	Remarks
1	Assistant Engineer (Maintenance)	Appointed as public information officer under RTI Act 2005	Circular No. MOM/8957 dt. 02.01.2006	
2	Sub Engineer (Maintenance)	Nil	N.A.	
3	Junior Engineer (Maintenance)	Nil	N.A.	

SECTION 4(1)(b) (ii)

The powers of offices and employees in the office of Assistant Engineer (Maint)

E- Judicial Powers

Sr. No.	Designation	Powers – Judicial	Under which legislation/rules/orders/GRs	Remarks
1	Assistant Engineer (Maintenance)	Nil	N.A.	
2	Sub Engineer (Maintenance)	Nil	N.A.	
3	Junior Engineer (Maintenance)	Nil	N.A.	

Section 4 (1) (b) (ii)

The duties of officers and employees in the office of Assistant Engineer (Maintenance & Repair)

ASSISTANT ENGINEER (MAINTENANCE & REPAIR)

Asstt. Engineer (Maintenance & Repair) of the ward work as per Mumbai Municipal Act, 1888, Maharashtra Regional & Town Planning Act, 1966. His work includes repairs and maintenance of Municipal Roads, Footpath, Ward Offices, Staff Quarters, Estate properties, Municipal Chowkies, Roads, Depots, Maternity Homes, Dispensaries, PSC Blocks, Municipal Cemeteries, Fire Brigade, Schools Welfare Centre, Conservancy Chawls, **desilting of minor nallas and road side S.W.D to minimize the flooding spots** either departmentally or through the e-tendering. He Issues Trench permission, Ganpati Mandap, Social, Regional Mandap Permission, Shooting Permission, acquire setback area of the road & merge the same into the Road, remove Bottleneck, demolish unauthorized encroachments on Municipal Roads, Footpath & Municipal properties.

Assistant Engineer (Maintenance & Repair) of the ward is responsible to Assistant Commissioner of the Ward and Zonal Dy.Municipal Commissioner for day-to-day work of the department in respect of administrative and policy work. He is also responsible to Ward Executive Engineer in respect of technical matters..

Asstt. Engineer (Maintenance & Repair) of the ward is assisted by Junior Engineer & Sub-Engineers to execute daily work. Respective Roads & Repairs Labour, Mukadam, Mistry, Carpenter, Mason, Plumber etc. help Junior Engineers & Sub-Engineers of the department to attained day to day complaints received.

Asstt .Engineer (Maintenance & Repair) of the Ward executes following duties/works from his staff working under his control:-

1. Exercise full control over the executive as well as the clerical and labour staff working in his section and ensure that all of them function efficiently.
2. Issuance of Trench permissions to various utilities as wel as to various departments of MCGM.
3. Issuance of Film shooting permission on Municipal Roads & properties.

4. Issuance of Ganpati Mandap/Navratri/social /religious permission on Municipal Roads & properties.
5. To acquired setback, bottle neck & Road Line.
6. To remove the encroachments on roads with the help of Sub Engineers and Jr. Engineers.
7. To supervise the work of store supervisor store clerk and the labours in the store and insure smooth functioning of the store.
8. To ensure that the necessary information is furnished to the concerned officers, in time and to take action on the defaulting staff, in case of delay.
9. To put up indents for the store item after discussion with the Sub Engineers and arrange for the requisite stock and to check for its quality and quantity. Material Checking norms.
 - 25 % of the store items, once in three months
 - 25 % of the depot items, once in three months
 - To dispose off the scrap material by following due procedure.
10. To carry out inspection to assess the condition of major roads.
11. To ensure prompt disposal of the complaints. To check the registers and daily diaries, at least fortnightly and monthly, respectively.
12. To exercise control on the municipal funds available, with the help of Head Clerk (Expenditure) and distribute the said funds among the Sub Engineers, appropriately and make them responsible for the utilization of funds.
13. To implement the orders issued by higher authorities.
14. To take appropriate action on the unauthorized constructions, detected on municipal roads & footpath.
15. To take timely action of propping, cordoning and demolition of dilapidated municipal buildings. To serve demolition notices on receipt of orders from the Executive Engineer or higher authorities.
16. To check at least 20 % of mass supply of materials and the contract bills. To check the estimate pertain to the repairs of municipal buildings, roads, etc. prepared by the Jr. Engineers & Sub Engineers.
17. To accept and serve notices under various Municipal Acts and take necessary action in the matter.

18. To visit major works in the ward at least once in a week.
19. To maintain the municipal properties and other buildings in the purview of the Estate Department (e.g. School, Hospitals, etc.)
20. To co-ordinate with the Law officers as regards the Court-case lodged by the MCGM or the matters against MCGM.
21. To get dilapidated municipal building vacated with the assistance of Police.
22. To visit the sites where labourers work and check on mustering once a month.
23. To co-ordinate with Central Agency as regards major repairs of municipal properties and maintenance of major roads.
24. To attend Ward Committee meetings in the ward office.
25. Review of SAP Complaints
26. Review of MCL A/B/C.
27. Review of MC-P.G. Cases
28. Review of Outstanding Audit Notes (Once monthly with MCA staff)
29. Review of pending Union problems (Once in Two months)
30. Enquiry procedure.
31. To maintain Daily Diary.
32. Desilting of minor nallas and road side SWD.
33. To minimize flooding spots during monsoon.
34. To provide missing manholes and dhapas.
35. Desilting of septic tanks of A.P blocks in slums and Gaothan.
36. To facilitate private layout in areas by providing necessary amenities by recommendation of Prakash Mehta Committee.
37. To provide facilities in slums, Adivasi pada and Gaothan.
38. To provide street lighting in area as per LUX value (illumination) of Reliance energy and TATA power
39. To provide information to applicant under R.T.I act of 2005
40. To attend 1 st and 2nd applicant under R.T.I act as public information officer.

To execute above mentioned works Labours, Mukadams, Mistry, Junior Engineers Sub-Engineers inspect their respective sub-sections and report to the Asstt. Engineer (Maintenance & Repair) of the ward. Based on these reports, further necessary actions are taken by the Asstt. Engineer and the Asstt. Commissioner of the ward and under guidance of the Ward Executive Engineer in case of technical matters.

Following registers are maintained by the office of the Asstt. Engineer (Maintenance & Repair) of the ward :-

1. Notice Register
2. Demolition Register
3. Property Register
4. Set back Register
5. R.T.I. Register
6. MCL A/B/C Register
7. Mandap Permission Register
8. M.C.A. Audit Register
9. F.R.D. Audit Register
10. P.R.D. Audit Register
11. Religious permission register

DUTIES OF SUB-ENGINEER (MAINTENANCE & REPAIR)

- 1) He shall be subordinate to the Asstt. Engineer and shall carry out their orders in general.
- 2) Supervision on departmental works.
- 3) To supervise each work under him at the start, during execution, completion and frequently as necessary.
- 4) Supervision on Funds available under various budget heads.
- 5) Timely submission of payments, bills and adjustments.

- 6) Site visit for major faults in the Municipal Buildings
- 7) Consolidation of revenue and outstanding requisition.
- 8) Supervision on employee muster books in order to see that the staff reports on duty in time and the fault entries are not made.
- 9) To check leave and service record and "Dead Stock" register and get them updated.
- 10) To ensure timely action in Court matters and order.
- 11) He shall draft replies to the complaints or references received in his section.
- 12) He shall attend the Courts as and when required for giving evidence helping the Sub. Engineer in conduction cases etc.
- 13) To take action against unauthorized structures / unauthorized developments on Municipal lands etc. as per M.M.C.Act and M.R.T.P.Act and as per the policy guidelines issued by time to times by the administration.
- 14) To monitor road work as road engineer.
- 15) Desilting of A.P block
- 16) To monitor desilting work of minor nalla and road side S.W.D
- 17) To monitor flooding spots and try to minimize the same
- 18) To monitor Ganpati idol immersion duties
- 19) To provide facilities in slum and Gaothan

To exercise, perform and discharge duties entrusted under Section 68(Municipal officers may be empowered to exercise certain powers, etc, of the Commissioner.) of M.M.C. Act as per the authority issued by Zonal D.M.C

- 1) He shall attend the various functions organized by the administration such as Disaster Management Plan, Swachhata Abhiyan, Anti Flooding Duties, Mahapaur Daud, Cleansing Camps, Advance Locality Management etc.
- 2) To maintain Daily Diary.
- 3) To maintain various registers such as :-
 1. Notice Register
 2. Demolition Register

3. Property Register
4. Set back Register
5. R.T.I. Register
6. MCL A/B/C Register
7. Mandap Permission Register
8. M.C.A. Audit Register
9. Religious permission register

DUTIES OF JUNIOR -ENGINEER (MAINTENANCE & REPAIR)

- 1) He shall be subordinate to the Asstt. Engineer & Sub Engineer and shall carry out their orders in general.
- 2) Supervision on departmental works.
- 3) To supervise each work under him at the start, during execution, completion and frequently as necessary.
- 4) Supervision on Funds available under various budget heads.
- 5) Timely submission of payments, bills and adjustments.
- 6) Routine site visit in his jurisdictional area.
- 7) Attending Site chowky and control the labours working under him.
- 8) To check leave and service record and "Dead Stock" register and get them updated.
- 9) To ensure timely action in Court matters and order.
- 10) To carry out joint inspection along with various utilities.
- 11) He shall draft replies to the complaints or references received in his section.
- 12) He shall attend the Courts as and when required for giving evidence helping the Sub. Engineer in conduction cases etc.
- 13) To take action against unauthorized structures / unauthorized developments on Municipal lands etc. as per M.M.C.Act and M.R.T.P.Act and as per the policy guidelines issued by time to times by the administration.

14)To exercise, perform and discharge duties entrusted under Section 68 of M.M.C.Act as per the authority issued by Zonal D.M.C

15)He shall attend the various functions organized by the administration such as Disaster Management Plan, Swachhata Abhiyan, Anti Flooding Duties, Mahapaur Daud, Cleansing Camps, Advance Locality Management etc.

16)To maintain various registers such as :-

1. Notice Register
2. Demolition Register
3. Property Register
4. Set back Register
5. R.T.I. Register
6. MCL A/B/C Register
7. Mandap Permission Register
8. M.C.A. Audit Register

9. Religious permission register

17) Desilting of A.P block

18) To monitor desilting work of minor nalla and road side S.W.D

19) To monitor flooding spots and try to minimize the same

20) To monitor Ganpati idol immersion duties

21) To provide facilities in slum and Gaothan

Section 4 (1) (b) (ii)

DELEGATION OF POWERS TO ASSISTANT ENGINEER

Under Section 68 of the Mumbai Municipal Corporation Act 1888 as amended up to date, Asstt Engineer (Maintenance & Repair) is hereby empowered to exercise, perform and discharge under the control and subject to the revision of the Commissioner, the several powers, duties and functions conferred or imposed upon or vested in the Commissioner by the several Sections, Sub-Sections and Clauses of the said Act herein below mentioned :-

EXPLANATION :- The entries in the second column of the below table headed 'Nature of powers' etc. are not intended as definitely described in Sections, Sub-Sections and Clauses mentioned in the first column or even as abstracts of those sections, sub-sections and clauses, the numbers of which are given in the first column.

Sections	Nature of Powers, Duties and Functions delegated
84 & 85(1)	(e) Grant Casual Leave to the inferior staff working under him upto the limit allowed by any rules for the time being in force. (f) Grant leave without pay admissible under the Rules to the Labour staff. To appoint when necessary, persons to act in place of employees who are absent on leave.
112	To receive money in respect of any matter pertaining to the City Engineer's Department.
113(3)	(a) To incur expenditure on office contingencies (except furniture) upto Rs.3000/- per item. (b) To make cash purchase and payment of bills out of imprest upto Rs.3000/- and payment of telephone call bills for any amount.
222(1) & (2)	To construct, repair or alter Municipal drains and to enter upon land for the

	purpose.
228	To grant permission and prescribed conditions as to communications with Municipal drains.
234	Determining details of drains and drainage fittings or cesspools for new buildings.
240	Granting permission for the construction of the drain so as to pass beneath building.
243(2)	Making requisition in respect of taps, covering and means of ventilation for drain and cesspools.
244(1)(4)	To erect shafts or pipes for ventilating drains and cesspools.
246-A	To permit the construction of water closets and privies.
247	Prescribing water closet and other accommodation in building newly created or re-erected.
248(1)(c)	Requisition to enforce provision of water closet or privy or urinal or bathing or washing place etc.
251	Determining details regarding water closets under Clauses (a)(d) and (e).
251(B)	To determine use of places of bathing or washing clothes or domestic utensils.
253	Inspection and examining drains, etc. not belonging to the Corporation.
254	Opening ground etc. for inspection and examination under Section 253.
255	Reinserting the ground etc. opened for purposes of inspection.
257	Making requisition on owners of premises as provided in Sub-Section (1) for doing the work mentioned in Sub-Section (2).
258(a)(b)(c)	Prohibition of acts, contravening the provisions under Chapter IX of the M.M.C.Act.
259-A	Requiring any person to employ a Licensed Plumber to execute a work to furnish the name of a Plumber and to put up completion certificate by the

	Licensed Plumber.
298(2)	To take possession or and clear the lands under this section.
311	To require owners to alter ground floor doors, etc. opening outward.
313(1)	To grant permission for placing stalls, chairs and benches, boxes, ladder, bales etc. on footpath and streets.
314	To remove obstructions etc. on streets made contrary to section 312 or 313.
317	To permit booths on festivals in certain streets.
321(2)	To prevent removal, etc. without permission of fences etc. erected in the streets, while works are in progress.
322	To prevent opening, etc. of streets unless done with permission and to give such permission.
324	To restore streets opened or broken up when the person responsible fails to do so.
325	To require person permitted to open streets to provide for diversion of traffic etc.
326(2)&(3)	To regulate hoarding etc. in streets.
329	To require and secure adoption of measures to protect and enclose dangerous places.
333(4)	Manner of laying gas pipes.
338	To require certain documents on receipt of Notice under Section 337.
339	To refuse to accept plans, etc. not signed by the Licensed Surveyor.
340	To require, further, particulars and details
342	To receive notices of intentions to make additions etc. to building.
343	To require certain documents and particulars on receipt of Notice under Section 342 and to refuse to accept plans, etc. not signed by Licensed Surveyor.

344-A	Supervision of buildings and work.
345	To intimate approval of work of which notice is received.
346(1)	To intimate disapproved of such work.
347(A)(B)& (C)	Prohibiting user of a non-residential buildings or chawl to a residential one and of a residential building or chawl to that of a godown, warehouse, workshop, workplace, factory, stable or a motor garage and prohibiting making or causing any alterations in an existing building originally constructed or authorized to be used for human habitation for the purpose of using it or causing it to be used as a godown, warehouse workshop, workplace, factory, stable or motor garage.
348(1)(a)(b) & (c)	Provision as to buildings, which are to be newly erected.
349	To refuse permission for walls, coverings, etc. of inflammable materials and to require removal of such wall or covering.
350	To inspect buildings in course of erection, alterations, etc
353	To specify any matter in contravention of Act of Bye Law within three months after completion.
353(A)	To grant completion certificate and permission to occupy or use.
354	To require removal etc. of ruinous or dangerous structures and to temporarily secure etc. repair etc.
354A(1)	To issue a written notice to stop within the specified period the erection of the work unlawfully carried on or commenced upon any premises.
354A(2)	To direct removal of person unlawfully carrying on the erection of buildings or the execution of any such works described in Section 342.
368	To require owners to provide receptacles of a size for collection of dust, ashes, refuse, rubbish and trade refuse, etc.
374	To inspect building or premises for the purpose of ascertain sanitary conditions thereof.

375	To require cleansing and lime washing of any building etc.
375-A	To require the owners to remove buildings, materials or debris, etc. accumulated due to house collapse etc.
377(1-A)	To require cleansing, clearing or enclosing any premises over grown with rank vegetation, etc.
377-A	To require the owners of the buildings to abate the nuisance arising from rainwater leaking from the roofs of the building or to prevent its recurrence.
380	To require removal, alteration etc., of unsanitary huts and sheds.
381	To require the owners of the building to abate the nuisance arising out of the defects.
383	To require cutting and looping of hedges, trees, etc. in certain cases and to take measures for protection of public.
394	To prohibit certain articles to be kept and certain trades processes and operation to be carried out without a license to exercise all other powers in respect of the things liable to be seized, destroyed etc, to prevent danger or nuisance.
396 Sub-section (1)	To inspect at any time, by day or by night without notice any premises used for manufacture as mentioned in Section 394 and any premises in which a furnaces employed for the purpose of manufacture and into any bake house to see whether any provision or this Act or any condition of any license is being contravened and as to whether any nuisance is created.
479(5)	To require production of licenses or written permission.
488	To enter into or upon buildings or and with or without Assistant or workment (1) for the purpose of exercising performing or discharging, the powers, duties or functions hereinabove delegated with reference to the sections above specified. The delegation of powers of entry under Section 488 is to be subject in each case to strict observance of and compliance with the provisions and conditions prescribed by Clauses (a), (b), (c) and (d) so far as applicable.

489	To take measures and execute work, etc, failure of compliance with requisitions or orders under provisions of the Act.
492(2)(a)	To call on occupiers to disclose rents for purpose of determining question of liabilities to pay expenses in certain cases.
517(1)(a)	To take or withdraw from proceedings against persons charged with offences against the Act etc. as described in Sub-Clauses (i),(ii) and (iii) of Clause (a).

Section 4 (1) (b) (ii)

DELEGATION OF POWERS TO SUB ENGINEER

Under Section 68 of the Mumbai Municipal Corporation Act 1888 as amended up to date, Sub -Engineer (Maintenance & Repair), Municipal Corporation of Greater Mumbai is hereby empowered to exercise, perform and discharge under the control and subject to the revision of the Commissioner, the several powers, duties and functions conferred or imposed upon or vested in the Commissioner by the several Sections, Sub-Sections and Clauses of the said Act herein below mentioned:-

EXPLANATION :- The entries in the second column of the below table headed 'Brief Description of Powers to be exercised and performed' are not intended as definitions described in Sections, Sub-Sections of these sections, but are inserted merely as reference to the subjects of the sections, sub-sections and the numbers of which are given in the first column.

Sections	Nature of Powers, Duties and Functions delegated
84 & 85(1)	a) Grant Casual Leave to the inferior staff working under him upto the limit allowed by any rules for the time being in force. b) Grant leave without pay admissible under the Rules to the Labour staff. To appoint when necessary, persons to act in place of employees who are absent on leave.
112	To receive money payments on account of the Municipal Fund and to lodge them in a bank.
222(1) & (2)	To cause to be served a notice of demand.
228	To grant permission and prescribed conditions as to communications with Municipal drains.
231	To enforce drainage of undrained premises situate within a hundred feet of a Municipal drains.
234	Determining details of drains and drainage fittings or cesspools for new buildings.
243(2)	Making requisition in respect of taps, covering and means of ventilation for

	drain and cesspools.
244(1)	To power affix pipes for ventilation of drains.
244(4)	To erect shafts or pipes for ventilating drains and cesspools
246-A	To permit the construction of water closets and privies.
247	Prescribing water closet and other accommodation in buildings newly created or re-erected.
248(1)(a), (b),(c)	Requisition to enforce provision of water closet or privy or urinal or bathing or washing place etc.
251	Determining details regarding water closets under Clauses (a)(d) and (e).
251(B)	To determine use of places of bathing or washing clothes or domestic utensils.
253	Inspecting and examining drains, etc. not belonging to the Corporation.
254	Opening ground etc. for inspection and examination under Section 253.
255	Reinstating the ground etc. opened for purposes of inspection.
257	Making requisition on owners of premises as provided in Sub-Section (1) for doing the work mentioned in Sub-Section (2).
258(a)(b)(c)	Prohibition of acts, contravening the provisions under Chapter IX of the M.M.C.Act.
259-A	Requiring any person to employ a Licensed Plumber to execute a work to furnish the name of a Plumber and to put up completion certificate by the Licensed Plumber.
314 (a), (b), (c)	To remove without notice things placed or deposited upon any place or attached or suspended in contravention of Clause (a) or Clause (c) or Sub-section (1) or Section 313.
317	To permit booths on festivals in certain streets.

322	To prevent opening, etc. of streets unless done with permission and to give such permission. (Except for newly constructed roads or capital roads)
322(3)	To remove without notice any building materials or any scaffolding or any temporary erection or any posts, bars, rails, boards or other things by way of enclosure which have been deposited or set up in any street without the permission or authority specified in Sub-section (1) or which having been deposited or set up with such permission or authority, have not been removed within the period specified in the notice issued under Section (2).
350	To inspect buildings in course of erection, alterations, etc.
354	To require removal etc. of ruinous or dangerous structures and to temporarily secure etc. repair etc.
354A(1)	To issue a written notice to stop within the specified period the erection of the work unlawfully carried on or commenced upon any premises.
354A(2)	To direct removal of person unlawfully carrying on the erection of buildings or the execution of any such works described in Section 342.
368	To require owners and occupiers to collect and deposit dust etc.
374	To inspect building or premises to ascertain sanitary conditions thereof.
375	To require cleansing and lime washing of any building etc.
375-A	To require the owners to remove buildings, materials or debris, etc. accumulated due to house collapse etc.
377	To make requisition against the owner or occupier for removal of rank vegetation.
377-A	To require the owners of the buildings to abate the nuisance arising from rainwater leaking from the roofs of the building or to prevent its recurrence.
380	To require removal, alteration etc., of unsanitary huts and sheds.
381	To require the owners of the building to abate the nuisance arising out of the defects.

383	To require cutting and looping of hedges, trees, etc. in certain cases and to take measures for protection of public.
390 (1) (2) (3)	Regulations of factories, trades, etc.
479(5)	To require production of licenses or written permission.
488	To enter premises with assistants etc. to inspect survey and execute works

Section 4 (1) (b) (ii)

DELEGATION OF POWERS TO JUNIOR ENGINEER

Under Section 68 of the Mumbai Municipal Corporation Act as amended up to date, Junior Engineer (Maintenance & Repair) under Asstt. Commissioner is hereby empowered to exercise, perform or discharge under the control and subject to the revision of the Commissioner, the under mentioned powers, duties and functions conferred or imposed upon or vested in the Commissioner by the several Sections, Sub-Sections and Clauses of the said Act herein below mentioned :-

EXPLANATION :- The entries in the second column of the below table headed 'Nature of Powers' etc. are not intended as definitely described in Sections, Sub-Sections and Clauses mentioned in the first column or even as abstracts of those sections, sub-sections and clauses but are inserted merely as reference to the subjects of the sections, sub-sections and clauses, the numbers of which are given in the first column.

Sections	Nature of Powers, Duties and Functions delegated
231	To enforce drainage of undrained premises situate within a hundred feet of a Municipal drains.
248(1)(c)	To substitute water closet accommodation for any privy accommodation.
253	To inspect and examine all drains, ventilation shafts and pipes cesspools of house gullies, water closets, privies, latrines and urinals to which this Section applied.
254	Opening ground etc. for inspection and examination under Section 253.
255	Reinstating the ground etc. opened for purposes of inspection.
314 (a), (b), (c)	To remove without notice things placed or deposited upon any place

	or attached or suspended in contravention of Clause (a) or Clause (c) or Sub-section (1) or Section 313.
322	To prevent opening, etc. of streets unless done with permission and to give such permission.
350	To inspect buildings in course of erection, alterations, etc.
354	To require removal etc. of ruinous or dangerous structures and to temporarily secure etc. repair etc.
354A(1)	To issue a written notice to stop within the specified period the erection of the work unlawfully carried on or commenced upon any premises.
354A(2)	To direct removal of person unlawfully carrying on the erection of buildings or the execution of any such works described in Section 342.
368	To require owners to provide receptacles of a size for collection of dust, ashes, refuse, rubbish and trade refuse, etc.
374	To inspect building or premises for the purpose to ascertain sanitary conditions thereof.
375	To require cleansing and lime washing of any building etc.
377	To make requisition against the owner or occupier for removal of rank vegetation.
377-A	To require the owners of the buildings to abate the nuisance arising from rainwater leaking from the roofs of the building or to prevent its recurrence.
380	To require removal, alteration etc., of unsanitary huts and sheds.
381	To require the owners of the building to abate the nuisance arising out of the defects.
390 (1) (2) (3)	Regulations of factories, trades, etc.

479(5)	To require production of licenses or written permission.
483	Service of notice - To serve, issue or present or give notices, bills schedules summonses and other such document required by this act to the served upon or issued or presented or given to any person.
488	<p>To enter into or upon buildings or land with or without Assistant or workmen.</p> <ol style="list-style-type: none"> <li data-bbox="459 510 1401 656">1. For the purpose of exercising performing or discharging, the powers, duties or functions hereinabove delegated with reference to the sections above specified. <li data-bbox="459 757 1401 958">2. For the purpose of carrying into effect under Section 489 any requisition or order (not only complied with) made by written notices by the Commissioner; under either of the following Section or Sub-section namely Section 257(1). Section 308 Sub-section(2)309, Sub-section(1), Section 311, Section 315(1), Section 325, Section 326(3), Section 329(1), Section 349, Section 351, Sub-section(2), Section 353, Section 354, Section 380 or Section 383(1). <li data-bbox="459 1395 1401 1942">3. For the purpose of leveling, metalling or paving, sewerage, draining, channeling and lightening any private street which the Commissioner with the sanction of the Standing Committee may be empowered under the provision of Section 305 level, metal or pave sewer drains, channel or light to his satisfaction or (1) for the purpose of removing altering or pulling down the building or work which the Commissioner with the approval of the Standing

	<p>Committee may be empowered under the provisions of Sub-section (2)</p> <p>of Section 351 to remove alter or pull down (5) for the purpose of Section 381(2) to fill up cover over or drain off</p> <p>a</p> <p>well, provided that a delegation of power of entry under Section 4888 is to be understood so be subject in each</p> <p>case</p> <p>to strict observance of and compliance with the provisions and conditions prescribed by Clauses (a),(b),(c) and (d) so far as applicable.</p>
--	--

Section 4 (1) (b) (ii)

Supervision Norms

Sr.No.	Designation	Supervision Norms
1	Asstt. Engineer (Maint)	To check at least 20 % of mass supply of materials and the contract bills. To check the estimate pertains to the repairs of municipal buildings, roads, etc. prepared by the Jr. Engineers & Sub Engineers.
2	Sub Engineer (Maint)/ Road Engineer	To supervise each work including road work as road engineer under him at the start, during execution, completion & frequently as necessary.
3	Junior Engineer (Maint)	To supervise each work under him at the start, during execution, completion and frequently as necessary and trench work as Trench (JE)

Section 4 (1) (b) (iii)

The procedure followed in the decision-making process, including channels of supervision and accountability in the office of Assistant Engineer (Maintenance & Repair)

NAME OF THE ACTIVITY:- Action against unauthorized encroachments detected on roads / footpath.

Related provisions:-

Name of the Act/ Acts :- MMC Act 1888 section 314

Rules:-

Govt. Resolutions:-

Circulars:-

Office Orders:-

Sr. No.	Activity as said above	Steps involved	Time Limit	Authority role and responsibility of the employee / officer in connection with each activity. (mention designation)	Remark
1	Complaint Received from Public, Staff, from higher authority and others.	1. Site visit	Within 24 Hours	JE / SE	
		2. Inspection Report		Junior Engineer	
		3. Issue 314 Notice if required	Within 7 days	J.E./ S.E. /A.E.	

		4. Arrange demolition by taking order from Asstt. Commissioner.	After expiry 48 Hours from order	J.E./ S.E. /A.E.	
		5. Entry in demolition register		J.E.	
		Demolition report		J.E./S.E.	
		Filing of W.S/A.I.R. in court, in case of stay granted by court restraining MCGM to take further action.	As directed by legal dept.	Junior Engineer / Sub Engineer	

NAME OF THE ACTIVITY: - BOTTLENECK :- Bottleneck means construction, narrowing, obstruction, congestion, block, partially/total blockage which leads to traffic congestion, traffic clogging problems started precipitating.

Related provisions:-

Name of the Act/ Acts :-

Rules:-

Govt. Resolutions:-

Circulars:- 1) AMC /ES/D 168 (Ch E/1876/DPC/Gen) Dated 25.02.2004

2) AMC/ES/9141/II dt.14.10.11

Office Orders:-

Sr. No.	Activity	Step involved	Time Limit	Authority role and responsibility of the employee / officer in connection with each activity. (mention designation)	Remark
1	Bottleneck				
		Preparation of Priority List of Bottlenecks.		Asstt. Commissioner/ A.E. (M & R) of Ward	
		Demarcation of Roads Sanctioned RL, Dp Roads	Within 15 Days from the receipt of the information received from	E.E. (T.C.) / A.E.(Survey) E.E. (D.P.) / A.E.(Survey)	

			the Asstt. Commissioner		
		Collection of Basic Data		J.E. (M & R)	
		Preparation of Inventory		J.E.(M & R) / S.E. (M & R)	
		Documents checking		S.E.(M & R) / A.E. (M & R)	
		Proposals Scrutiny and submission to Competent Authority		Ward E.E.	
		Sanction of Competent Authority		Additions M.C.'s of Zone	
		Removal of Bottleneck		Asstt. Commissioner/ A.E. (M & R) of Ward	
		Roads/ S.W.D. Developments		Ch. Engg (Roads)/Ch. Engg (S.W.D.)	
		Final Compliance to Zonal DMC/Jt. MC's		Asstt. Commissioner of Ward	

NAME OF THE ACTIVITY:- E-tendering

Related provisions:-

Name of the Act/ Acts :-

Rules:-

Govt. Resolutions:-

Circulars:-

Office Orders:-

Sr. No.	Activity	Step involved	Time Limit	Authority role and responsibility of the employee / officer in connection with each activity. (mention designation)	Remark
1	E-tendering	Preparation of Estimate		J.E.	
		Administrative approval		Ward Committee or DMC etc.	
		Estimate is uploaded in SAP System in A.E. or SE's ID (R3 Module)		S.E.	
		BID is created in SRM Module E tendering.		S.E.	
		BID is forwarded to E.E. Ward for publishing on Municipal Website.		S.E.	
		Publish the Tender (SRM E tender login Approval)		Ward E.E.	

		List of Bidder and letter to successful 1 st Bidder with 5 % contract amount to deposit with MCGM.		MCGM Website & A.E./S.E.	
		PO is created in SAP Module.		A.E.	
		Release P.O. Amount.		Account officer	
		Create Contract in SAP System.		Ward E.E.	
		PO is generated in SAP.		A.E.	
		PO is released.		Ward E.E.	
		PO printout is taken and issued to Bidder.		A.E.	

NAME OF THE ACTIVITY: - Permission for trench

Related provisions:-

Name of the Act/ Acts:-

Rules:-

Govt. Resolutions:-

Circulars:-

- MGC/F/1835 dated 17.11.2007
- MGC/F/9974 dated 04.02.2013
- ChE/804/SR/Rds, Tr. & Br. Dated 05.02.2013
- ChE/525/SR/Roads dated
- ChE/11888/Rds/SR dated 09.03.2012
- ChE/1075/Roads dated 31.09.2012
- ChE/857/SR/Roads dated 18.02.2012
- Ch.Eng/727/SR/Rds dated 19.03.2010
- AMC/ES/8879/II dated 05.04.2013.

- Ch.E/396/SR/Rds & Tr. Dt.12.09.2013
- Ch.E/455/SR/Rds dated 09.10.2013
- Office Orders:- AMC / ES / 5461 / II DTD. 05/04/2014

- AMC / ES / 5432 / II DTD. 07/04/2014

- AMC / ES / 5597 / II DTD. 21/04/2014

Sr. No.	Activity	Step involved	Time Limit	Authority role and responsibility of the employee / officer in connection with each activity. (mention designation)	Remark
1	Trench Permission	As per above circulars			

NAME OF THE ACTIVITY:- Permission for Ganapati Mandap

Related provisions:-

Name of the Act/ Acts:-

Rules:-

Govt. Resolutions:-

Circulars:-

- MDF/OD/8358/Gen datd11.06.2013
- MDF/9629/Gen dated 25.07.2008
- AA/ES/4528 dated 28.07.2008
- AA/ES/D/1971 dated 02.07.2007

AA/9269/Jahirat/201212 dated30.08.2012AMC/ES/8879/II dated 05.04.2013.

Office Orders:-

Sr. No.	Activity	Step involved	Time Limit	Authority role and responsibility of the employee / officer in connection with each activity. (mention designation)	Remark
1	Ganapati Mandap Permission	Scrutiny of documents on receipt of application.	7 days	J.E./S.E.	
		Site Inspection	7 days	J.E./S.E.	
		To demand additional documents/NOC required from applicant, if any.	Within 15 days	J.E./S.E.	
		Forward for Road Engineer's NOC.	Within 15 days	J.E./S.E.	

		To issue demand letter & permission charges after receipt of all required documents.	Within 15 days	J.E./S.E.	
		To issue permission on obtaining approval from competent authority. (Permission is refused if applicant has not submitted all required documents)			

Section 4 (1) (b) (iv)

Norms set for discharge of its functions in the office of Assistant Engineer (Maintenance & Repair)

Organizational targets (Annual)

Sr. No	Designation	Activity	Financial Targets in Rs.	Time Limit	Remark
1	Asstt.Engineer (M & R)	As mentioned in Section 4 (1)(b)(ii)	There are no financial targets set for this department. As mentioned earlier the work is carried out on day to day basis.	Time limit for each activity is as mentioned in Section 4(1)(b)(iii)	
2	Sub Engineer (M & R)	As mentioned in Section 4 (1)(b)(ii)	There are no financial targets set for this department. As mentioned earlier the work is carried out on day to day basis.	Time limit for each activity is as mentioned in Section 4(1)(b)(iii)	
3	Junior Engineer (M & R)	As mentioned in Section 4 (1)(b)(ii)	There are no financial targets set for this department. As mentioned earlier the work is carried out on day to day basis.	Time limit for each activity is as mentioned in Section 4(1)(b)(iii)	

Section 4 (1) (b) (v)
The rules / regulation related with the functions of Assistant Engineer
(Maintenance & Repair)

Sr. No.	Subject	G.R. /Circular / Office order. Rule no. Notification etc. date.	Remarks if any
1	Trench	<ul style="list-style-type: none"> • MGC/F/1835 dated 17.11.2007 • MGC/F/9974 dated 04.02.2013 • ChE/804/SR/Rds, Tr. & Br. Dated 05.02.2013 • ChE/525/SR/Roads dated • ChE/11888/Rds/SR dated 09.03.2012 • ChE/1075/Roads dated 31.09.2012 • ChE/857/SR/Roads dated 18.02.2012 • Ch.Eng/727/SR/Rds dated 19.03.2010 • AMC/ES/8879/II dated 05.04.2013. • Ch.E/396/SR/Rds & Tr. Dt.12.09.2013 • Ch.E./455/SR/Rds Dated 09.10.2013 • AMC / ES / 5461 / II DTD. 05/04/2014 • AMC / ES / 5432 / II DTD. 07/04/2014 • AMC / ES / 5597 / II DTD. 21/04/2014 	
2	Ganapati Mandap Permission	<ul style="list-style-type: none"> • MDF/OD/8358/Gen datd11.06.2013 • MDF/9629/Gen dated 25.07.2008 • AA/ES/4528 dated 28.07.2008 • AA/ES/D/1971 dated 02.07.2007 • AA/9269/Jahirat/201212 dated30.08.2012 	
3	Pothole	<ul style="list-style-type: none"> • Dy. Ch. Eng/1901/Rds(City) dated 15.06.2013 • MGC/F/1074 dated 06.07.2013 • CA/FDT/59 dated 16.03.2013 	
4	E-tendering	<ul style="list-style-type: none"> • CA/FRD/7 dated 17.05.2013 • CA/CPD/36 dated 03.11.2012 	
5	Pay & Park	<ul style="list-style-type: none"> • Dy.ChE/1380/Traffic of 23.05.2013 	
6	Shooting Permission	<ul style="list-style-type: none"> • CA/FRM/3 dated 10.04.2013 	
7	Mahatma Gandhi Pathkranti Yojana	<ul style="list-style-type: none"> • DMC/Special/OD/5468/dated06.03.2012 • DMC/Special/5447 dated03.03.2012 • AMC/ES/944/IV dated 31.03.2012 	
8	Bottleneck	<ul style="list-style-type: none"> • AMC/ES/9141/II dt.14.10.11 	

9	Conversion of Zunaka Bhakar Kendra into Annadata Aahar Kendra	<ul style="list-style-type: none">• AC (PLANNING) / 250 dtd. 30/05/2009• CORPORATION RESOLUTION NO. 1310 DTD. 25/02/2009• IN CONTINUATION WITH AC (PLANNING) / 5890 DTD. 20/03/2013	
---	---	---	--

Section 4 (1) (b) (vi)

**Statement of Categories of documents held in the office of Assistant Engineer
(Maintenance & Repair)**

Sr. No.	Subject	Type of Document file or register	File No. or Register No.	Particulars	Periodicity of Preservation (Proposed)
'C1' Class Record					
1	Demolition Register	Register		Details of demolitions of unauthorized work carried out under various sections of MMC Act	10 Years
'C' Class Record					
1.	R.T.I Register	Register		Details of application received under R.T.I.Act, replied/forwarded & transferred date.	5 Years
2	Work Orders	Documents		Details of work orders issued to contractor by department	5 Years
3	Measurement Books	Documents		Details of Measurements recorded in M.B.	5 Years
4	Payment Certificate	Documents		Details of Payments issued to the contractor	5 Years
5	Demand Notes & Permits	Documents		Details of Demand Notes & Permits issued to various utility agencies.	5 Years
6	Mandap Permission	Register		Details of Mandap Permission issued to various applicants.	5 Years
'D' Class Record					
1	Log sheets	Inward papers		Details of Applications/ complaints/ other documents received by department	01 Year
2.	Outward Register(Internal departments)	Outward papers		Details of Applications/ complaints/ other documents forwarded to Internal departments of K/East ward.	01 Year
3.	Outward Register	Outward papers		Details of Applications/ complaints/ other	01 Year

	(External correspondence)			documents forwarded to external departments of MCGM/ Other Govt. authorities and correspondence with applicants/ complainants /citizens etc.	
4.	Complaint Register	Register		Orally complaint registered.	01 year
5.	RTI application & their reply (Except appeal cases)	Document		Details of application received under RTI Act & reply given to the same.	01 year
6.	First & second appeal made under RTI Act	Document		Details of First & second appeal made by applicant under RTI Act by the applicant against reply of Public Information Officer and/or order passed by First Appellate Authority	01 year
7	Monthly reports sent to various departments	Document		File papers containing monthly reports sent to various departments	01 years
8	Demolition of structures under MMC Act, MRTP Act & other action completed	Nasti		Nasti files containing papers pertaining to the notice action against structures demolished under MMC Act, MRTP Act & other actions.	01 year (after demolition)

Section 4 (1) (b) (vii)

Particulars of any arrangement that exists for consultation with the members of public in relation to the formulation of policy and implementation in the office of Assistant Engineer (Maintenance & Repair)

Sr. No.	Consultation for	Details of Mechanism	Under which legislation / rules / orders / GRs	Periodicity
1	Policy Details	Ward Committee	Nil	Once in a Month

Section 4 (1) (b) (viii)

**Statement of Boards, Councils, Committees or Other bodies of office of Asstt Engineer
(Maintenance & Repair)**

Sr. No.	Name of the committee board / council / other bodies	Compositio n of committee Board council other bodies	Purpose of the committe e Board/ Council/ other bodies	Frequency of meetings	Whether meeting open to public or not	Whethe r Minutes are availabl e to public or not	Minutes available at.
1	Advance Locality Managem ent (ALMI	Nil	Nil	Nil	Nil	Nil	Nil
2	Local Area Citizens Committee (LACC)	Nil	Nil	Nil	Nil	Nil	Nil
3	Local Area Citizens Group (LACG)	Nil	Nil	Nil	Nil	Nil	Nil

Section 4(1) (b) (ix)

Directory of the officers and employees in the office of Assistant Engineer (Maintenance & Repair)
K/East ward

Sr No	Designation	Name of officers/Employees	Cadre	Dt. Of Joining the post	Contact Details Ph/Fax/E-mail
1	Asst. Eng	Ghalsashi Milind Mukund	B		022-26840103
2	Asst. Eng	Bodkhe Umesh C	B	23/01/1996	022-26840103
3	Sub Eng	Sonawane Namrata Subhash	B	30/05/2013	022-26840103
4	Sub Eng	Rajas Rohit Vishwanath	B	12/03/2007	022-26840103
5	Sub Eng	Gurao Rajiv Balkrishna	B		022-26840103
6	Sub Eng	Patil Ranjit Hindurao	B	23/02/2007	022-26840103
7	Sub Eng	Kale Amit Vijay	B		022-26840103
8	Sub Eng	Pandey Rakesh Mahatam	B	12/3/2007	022-26840103
9	Jr. Eng	Dhende Vishwas Appasaheb	C	6/6/2013	022-26840103
10	Jr. Eng	Sarwade Sachin Laxmanrao	C		022-26840103
11	Jr. Eng	Jadhav Archana Shrikant	C	24/6/2008	022-26840103
12	Jr. Eng	Kulkarni Santosh	C	7/07/2008	022-26840103
13	Jr. Eng	Narkar Nilesh Ganpat	C	25/06/2008	022-26840103
14	Jr. Eng	Jadhav Nitesh Ramchandra	C	4/7/2008	022-26840103
15	Jr. Eng	Girgonkar Ramesh Gangaram	C		022-26840103
16	Jr. Eng	Jadhav Milind Raghunath	C	9/03/2009	022-26840103
17	Jr. Eng	Khedkar Amol Pandurang	C	23/11/2011	022-26840103
18	Jr. Eng	Bos Kunal Dnyaneshwar	C		022-26840103
19	Jr. Eng	Kamble Kiran Ramrao	C	4/10/2013	022-26840103
20	Jr. Eng	Deshmukh Pallavi P	C	02/11/2013	022-26840103
21	Jr. Eng	Yedle dattatrya Dilip	C	6/11/2013	022-26840103

22	Jr. Eng	Danole Tushar Jivandhar	C	17/09/2013	022-26840103
23	Jr. Eng	Dalavi Nisha Vikas	C	14/07/2008	022-26840103
24	Store Clerk	Pedhnekar Sanjay Namdeo	C		022-26840103
25	Labourer	Sabnna Tayappa Dhangar	D	1/3/1980	
26	Labourer	Shankar Badridas	D	13/11/1981	
27	Labourer	Aanna Sakharam Pawar	D	13/11/1981	
28	Labourer	Ashok Hari Sawant	D	19/11/1981	
29	Labourer	Chotalal Murali Bairagi	D	3/12/1981	
30	Labourer	Dharmraj Sukhlal Bairagi	D	23/04/1982	
31	Labourer	Shridhar Nivrutti Kedar	D	1/6/1983	
32	Labourer	Vilas Masku Shinde	D	1/6/1983	
33	Labourer	Mohan Kachur Rokade	D	1/6/1983	
34	Labourer	Suresh Sawala Jadhav	D	1/6/1983	
35	Labourer	Dhaji Sawkar Khoutode	D	1/6/1983	
36	Labourer	Kashinath Tanu Parbate	D	18/07/1983	
37	Labourer	Phulchand Yashwant Kadam	D	1/11/1983	
38	Labourer	Mahadev Gopal Sawant	D	1/11/1983	
39	Labourer	Mahammad Hadi M	D	1/11/1983	
40	Labourer	Vijay Gunaji Sawant	D	1/11/1983	
41	Labourer	Keshav Gagngaram Khochade	D	1/11/1983	
42	Labourer	Amrutrama Anantrao battula	D	1/12/1986	
43	Labourer	Mahmmad Salim Akbar Sharif	D	1/12/1986	
44	Labourer	Ganpati Sadu Chavan	D	8/8/1987	
45	Labourer	Mahadev Govind Tegade	D	1/11/1988	
46	Labourer	Vijat Yashwant Kadam	D	1/11/1988	
47	Labourer	Anant Dhondu Vedruk	D	1/11/1988	
48	Labourer	Ashok Babu Pawar	D	1/11/1988	

49	Labourer	Vishwanath Raghu Bodake	D	19/12/1988	
50	Labourer	Yalappa Phakirppa Asangi	D	20/12/1988	
51	Labourer	Mahmmad Rais ellihis	D	17/10/1989	
52	Labourer	Ashok Bhiva Suvare	D	3/11/1989	
53	Labourer	Shantaram Rama Parbate	D	3/11/1989	
54	Labourer	Ramesh Pandhari Tayde	D	3/11/1989	
55	Labourer	Nagesh Dattaram Hate	D	3/11/1989	
56	Labourer	Raju Aarmugam Raman	D	3/11/1989	
57	Labourer	Ganpat Bhaga Nadankar	D	3/11/1989	
58	Labourer	Karpayya Marimuttu	D	3/11/1989	
59	Labourer	Devidas Hirappa Sindal	D	3/11/1989	
60	Labourer	Adhik Jaywant Sonavane	D	3/11/1989	
61	Labourer	Vardharaj Ramswami	D	3/11/1989	
62	Labourer	Ajj Siddhiki	D	3/11/1989	
63	Labourer	Ramadhar S Bairagi	D	3/11/1989	
64	Labourer	Yeshudas Petras Thorat	D	3/11/1989	
65	Labourer	Mahadu Babu Pawar	D	4/11/1989	
66	Labourer	Gangaram Gunaji Tamhnkar	D	4/11/1989	
67	Labourer	Gangaram Gurkha Dagade	D	4/11/1989	
68	Labourer	Prakash Bhikaji Kambale	D	11/11/1989	
69	Labourer	Dattaram babu Mohanmanjal	D	25/11/1989	
70	Labourer	Mahendra Sahadev Surave	D	1/9/1990	
71	Labourer	Arjun Shivprasad Thakur	D	1/9/1990	
72	Labourer	Suresh Bayaji Jadhav	D	12/12/1990	
73	Labourer	Sakharam Sitaram Kalnbate	D	12/12/1990	
74	Labourer	Prakash Ravaji Thik	D	21/12/1990	
75	Labourer	Ramswami Pirmal	D	24/01/1991	

76	Labourer	Dasharth Tanu Parbate	D	1/2/1991	
77	Labourer	Bhimrao Yalappa Pawar	D	6/2/1991	
78	Labourer	Shantaram Shankar Main	D	10/6/1991	
79	Labourer	Ganesh Punswami	D	17/7/1991	
80	Labourer	Vilas Lobha Unhavane	D	23/10/1991	
81	Labourer	Babu Yalappa Pawar	D	1/1/1992	
82	Labourer	Ramchandra Babu KunchiKorave	D	2/1/1992	
83	Labourer	Milind Bhanudas Khare	D	10/1/1992	
84	Labourer	Ramtirath Rambarn Nishad	D	29/01/1992	
85	Labourer	Vilas Shankar Khaire	D	29/01/1992	
86	Labourer	Rajaram Bhikaji Pilake	D	29/01/1992	
87	Labourer	Suryakant Krushna Shikhare	D	29/01/1992	
88	Labourer	Ashok Jijaba Sarvade	D	1/2/1992	
89	Labourer	Chatrapati Bhimrao Gaikwad	D	1/2/1992	
90	Labourer	Prabhakar Bistur Vaiti	D	1/2/1992	
91	Labourer	Appa Kahndu Jadhav	D	1/2/1992	
92	Labourer	Pravin Bhagvan Maru	D	1/2/1992	
93	Labourer	Gautam Janardan Javale	D	13/02/1992	
94	Labourer	Mohan Gangaram Shelar	D	18/02/1992	
95	Labourer	Shubhash Bal Bavkar	D	12/3/1992	
96	Labourer	Ganpat Kashiram Kambale	D	3/4/1992	
97	Labourer	Bhujang Shankar Shejval	D	11/4/1992	
98	Labourer	Sanjay Sitaram Pawar	D	27/06/1992	
99	Labourer	Kashiram Sitaram Kambale	D	7/9/1992	
100	Labourer	Anant Shivram jadhav	D	17/09/1992	
101	Labourer	Dashrath Dagadu Jadhav	D	17/09/1992	
102	Labourer	Surendra Gopichand Mayekar	D	17/09/1992	

103	Labourer	Narayan Beru Aamraskar	D	17/09/1992	
104	Labourer	Sunil Mahadev Bansode	D	17/09/1992	
105	Labourer	Aravind Manohar Pawar	D	17/09/1992	
106	Labourer	Mithailal Ramlutavan kori	D	16/02/1993	
107	Labourer	Gautam Trimbak Bodhare	D	15/04/1993	
108	Labourer	Dilip Bansi Lokhande	D	23/04/1993	
109	Labourer	Mahedra Bhiku Jadhav	D	24/09/1993	
110	Labourer	Gajanan Shankar Chavan	D	24/09/1993	
111	Labourer	Panchiri Prabhakar Vekanti	D	24/09/1993	
112	Labourer	Prakash Ashru Rajguru	D	24/09/1993	
113	Labourer	Anant Nagu Solkar	D	24/09/1993	
114	Labourer	Vilas Gangaram Sawant	D	24/09/1993	
115	Labourer	Ganesh Govind Gaikwad	D	12/11/1993	
116	Labourer	Laxmi Parshuram Kase	D	1/12/1994	
117	Labourer	Periswami Nach Devkr	D	18/01/19985	
118	Labourer	Gurunath Raghunath Khaire	D	18/01/1995	
119	Labourer	Prakash manakya Kambale	D	18/01/1995	
120	Labourer	Sunil Shivdas Narayane	D	1/2/1995	
121	Labourer	Pravin Anant Bhosale	D	4/5/1995	
122	Labourer	Velayutham Shrirangan Kuppaswami	D	15/06/1995	
123	Labourer	Deepak Tukaram Jadhav	D	17/07/1995	
124	Labourer	Sureshkumar Chimanlal Mitana	D	1/9/1995	
125	Labourer	Muralidhar Devrav Jogdande	D	1/9/1995	
126	Labourer	Jaywant Ramchandra Shinde	D	1/9/1995	
127	Labourer	Suhas Vasudev Kubal	D	1/9/1995	
128	Labourer	Ravindra Shankar Vichare	D	1/9/1995	
129	Labourer	Tuashiram Mahadev Tapase	D	1/9/1995	

130	Labourer	Prakash Vishram Velaye	D	1/9/1995	
131	Labourer	Ramdas Mhasku Shinde	D	1/9/1995	
132	Labourer	Bhivchand Bhaga Pandit	D	1/9/1995	
133	Labourer	Umesh Pandhari Kankonkar	D	1/9/1995	
134	Labourer	Mahadev Krishnaji Bandkar	D	1/9/1995	
135	Labourer	Chandrakant Babu Hatpale	D	1/9/1995	
136	Labourer	Gajendra Nathuram Vanjare	D	1/9/1995	
137	Labourer	Nanda Mhasku Shinde	D	1/9/1995	
138	Labourer	Subhash Babu Narayane	D	1/9/1995	
139	Labourer	Krishankumar Prabhuram Chavriya	D	1/9/1995	
140	Labourer	Annasaheb Yelappa Kunchikorave	D	1/9/1995	
141	Labourer	Rajendra Rama Shejval	D	1/9/1995	
142	Labourer	Nazir Husain Alibhai	D	1/9/1995	
143	Labourer	Baijnath Rajitram Pandye	D	1/9/1995	
144	Labourer	Surendra Govind Korlekar	D	1/9/1995	
145	Labourer	Narayan Yelappa Pawar	D	1/9/1995	
146	Labourer	Kantaram Krushna Keni	D	1/9/1995	
147	Labourer	Sitaram Krishna Thik	D	1/9/1995	
148	Labourer	Dilip Aatmaram Chavan	D	1/9/1995	
149	Labourer	S Maikel Savarimuttu	D	1/9/1995	
150	Labourer	Krishna Vishram Sawant	D	1/9/1995	
151	Labourer	Rameshchandra Kisan Rathod	D	1/9/1995	
152	Labourer	Mohan Ravaji Thik	D	1/9/1995	
153	Labourer	Madhukar Kerba Patil	D	1/9/1995	
154	Labourer	Ashok Sahebrav Sonavane	D	1/9/1995	
155	Labourer	Sanjay Deu Aarekar	D	1/9/1995	
156	Labourer	Krishna Ramchandra Gore	D	1/9/1995	

157	Labourer	Balu Punaji Rokade	D	1/9/1995	
158	Labourer	Bhagvan Pandhari Ughade	D	1/9/1995	
159	Labourer	Bhagavat Tukaram Jadhav	D	1/9/1995	
160	Labourer	Chandrakant Laxuman Pawar	D	1/9/1995	
161	Labourer	Subhash Pandurang Vaghmare	D	1/9/1995	
162	Labourer	Janappa Tukaram Bansode	D	1/9/1995	
163	Labourer	Ravindra Sakharam Jadhav	D	1/9/1995	
164	Labourer	Manoj Gajanan Karjavkar	D	1/9/1995	
165	Labourer	Premnath Anant Kambale	D	1/9/1995	
166	Labourer	Shashikant Jagannath Kadam	D	1/9/1995	
167	Labourer	Ramesh Chima Kurade	D	1/9/1995	
168	Labourer	Ramesh Muralidhar Ghoderao	D	1/9/1995	
169	Labourer	Vasant Mahadev Bibvekar	D	1/9/1995	
170	Labourer	Venktesh Laxmuman Patel	D	1/9/1995	
171	Labourer	Pradeep Ramchandra Jogmekar	D	1/9/1995	
172	Labourer	Pritam Janu Betakar	D	1/9/1995	
173	Labourer	Mohan Anand Masale	D	1/9/1995	
174	Labourer C Watchmen	Suaraj Babulal Bairagi	D	1/9/1995	
175	Labourer	Mangesh Vasant Kadam	D	1/9/1995	
176	Labourer	Sudhakar Vasant Aayre	D	1/9/1995	
177	Labourer	Saybu Laxuman Pawar	D	1/9/1995	
178	Labourer	Chetan Ashok Dandekar	D	1/9/1995	
179	Labourer	Nana Bapurao Rokade	D	1/9/1995	
180	Labourer	Mataprasad S Bairagi	D	1/9/1995	
181	Labourer	Prakash Dhaku Pawar	D	1/9/1995	
182	Labourer	Prakash Gunaji Kambale	D	1/9/1995	
183	Labourer C Watchmen	Maruti Rajaram More	D	1/9/1995	

184	Labourer	Sukhadev Bhiku Vaghmode	D	1/9/1995	
185	Labourer	Dadasaheb Nagu Dagale	D	1/9/1995	
186	Labourer	Nelsan Endru Dibrito	D	1/9/1995	
187	Labourer	Ashok Bajirao Avasarmal	D	1/9/1995	
188	Labourer	Vilas Vasudev Kavale	D	1/9/1995	
189	Labourer	Anilkumar Mithalal Bairagi	D	1/9/1995	
190	Labourer	Mohanlal Ramaadhar	D	2/9/1995	
191	Labourer	Birayya Nagyya Sontik	D	4/9/1995	
192	Labourer	Sadanand Gangaram Patil	D	6/9/1995	
193	Labourer	Shivram Gangaram Berde	D	6/9/1995	
194	Labourer	Vijay Mohan Manjrekar	D	6/9/1995	
195	Labourer	Manohar Dyaniyal Thorat	D	6/9/1995	
196	Labourer	Rajendra Gopal Salavi	D	13/09/1995	
197	Labourer	Posamallu Gatayya Elgam	D	25/01/1996	
198	Labourer	Satyavan Kashiram Manjrekar	D	8/5/1996	
199	Labourer	Ashok Sunkappa Kadar	D	14/03/1997	
200	Labourer	Yankappa Gangaram Enreddy	D	17/08/2007	
201	Labourer	Shantaram Devram Dhindale	D	13/06/2008	
202	Labourer	Balu Bhiva Bhangare	D	13/06/2008	
203	Labourer	Umesh Eknath Chavan	D	26/06/2008	
204	Labourer	Sitaram Laxmun Shengale	D	8/7/2008	
205	Labourer	Eknath Kaluram Bhoir	D	15/07/2008	
206	Labourer	Prakash Radkya Bhoir	D	23/07/2008	
207	Labourer	Sanjay Ramchandra Amate	D	29/07/2008	
208	Labourer	Sandeep Baban Patil	D	2/8/2008	
209	Labourer	Kishor Raman Macchi	D	8/8/2008	
210	Labourer	Sanjay Vinayak Patil	D	9/8/2008	

211	Labourer	Nitinkumar Jaannath Choudhari	D	9/8/2008	
212	Labourer	Dattatray Vasudev Kinee	D	9/8/2008	
213	Labourer	Pankaj Govind Gavad	D	9/8/2008	
214	Labourer	Vishal Kamlakar Choudhari	D	12/8/2008	
215	Labourer	Surendra Aasaram Malevar	D	13/08/2008	
216	Labourer	Jivak Hindurav Jagatap	D	18/09/2008	
217	Labourer	Mahadev Rohidas Survase	D	17/11/2008	
218	Labourer	Dnyaneshwar Bapurao Bagade	D	16/11/2009	
219	Labourer	Sandeep Dadu Patil	D	19/01/2010	
220	Labourer	Rameshchandra Radheshyam Yadav	D	2/3/2010	
221	Labourer	Ganesh Anandrao Sutar	D	2/3/2010	
222	Labourer	Deepak Jibhau Ahire	D	23/03/2010	
223	Labourer	Sandeep Shahuraj Jogadndakar	D	20/07/2010	
224	Labourer	Santosh Jappa Kadar	D	17/03/2011	
225	Labourer	Girish Laxmiman Makvana	D	6/5/2011	
226	Labourer	Vilas Rama Bhoir	D	5/9/2011	
227	Labourer	Anaji Govind Gode	D	12/9/2011	
228	Labourer	Gorakha Gangaram Khade	D	12/9/2011	
229	Labourer	Ramesh Chandrakant Kadam	D	15/09/2011	
230	Labourer	Vilas Tulasiram Ghane	D	23/09/2011	
231	Labourer	Dattatray Vittal Zole	D	1/10/2011	
232	Labourer	Yusuf Ismail Tadavi	D	1/10/2011	
233	Labourer	Bajirao Dattatray Kunde	D	1/10/2011	
234	Labourer	Dnyaneshwar Mohan Jadhav	D	1/10/2011	
235	Labourer	Dinesh Sudhakar Shejval	D	5/10/2011	
236	Labourer	Satish Bhimrao Gotis	D	5/10/2011	
237	Labourer	Ramesh Sakharam Dagale	D	5/10/2011	

238	Labourer	Ganesh Mahadu Kunde	D	5/10/2011	
239	Labourer	Pradeep Dinkar Pote	D	8/11/2011	
240	Labourer	Rohidas Sakharam Ungale	D	8/11/2011	
241	Labourer	Shivaji Tukaram Mali	D	8/11/2011	
242	Labourer	Laxuman Kondu Lohakare	D	9/11/2011	
243	Labourer	Gopinath Mahadu Bhoir	D	21/11/2011	
244	Labourer	Nivarutti Bhima Lande	D	21/11/2011	
245	Labourer	Ashok Vana More	D	10/12/2011	
246	Labourer	Sandeep Lau Bhatale	D	4/6/2012	
247	Labourer	Santosh Yellanna Dhotre	D	5/7/2012	
248	Labourer	Raju Parshuram Shilvant	D	9/7/2012	
249	Labourer	Marugvel Tangrajan	D	23/07/2012	
250	Labourer	Bharat Shyam kunchikovare	D	1/9/2012	
251	Labourer	Ganesh Chandrakant Mandavkar	D	1/2/2014	
252	Mistry II	Kush Vankatesh Kankonkar	D	13/05/2013	
253	Mistry II	Babasaheb Damu Magade	D	13/05/2013	
254	Mason II	Yadgiri Malanna Kodadi	D	5/5/1979	
255	Mason II	Shankar Jayram Tamhnakar	D	11/2/2005	
256	Mason II	Dattaram Umaji Omale	D	17/11/2006	
257	Mason II	Siddharth Keru Sawant	D	1/1/2009	
258	Mason II	Prakash Sahadev Bane	D	8/2/2013	
259	Mukadam	Duryodhan Dhakappa Bhorkade	D	13/12/1988	
260	Mukadam	Laxuman Shankar Bilaskar	D	2/12/1991	
261	Mukadam	Mohan Dudhaba Inkar	D	8/2/1993	
262	Mukadam	Premdas Bhagvat Salave	D	12/4/1993	
263	Mukadam	Maruti Mukund More	D	1/1/1998	
264	Mukadam	Gokul Dattatray Buva	D	1/6/1998	

265	Mukadam	Kashinath Lahanu Borade	D	1/7/1997	
266	Mukadam	Chandrakant Gopal Vaghmare	D	1/7/1998	
267	Mukadam	Chandrakant Krishna Vaiti	D	1/10/2003	
268	Mukadam	Yashwant Dhondu Shinde	D	22/10/2003	
269	Mukadam	Sopan Kushaba Supe	D	21/07/2006	
270	Mukadam	Chandrakant Vitthal Burud	D	15/12/2006	
271	Mukadam	Sharif Hasan Malak	D	8/2/2013	
272	Mukadam	Ganpat Soma Karmbele	D	8/2/2013	
273	Mukadam	Sitaram Rajaram Gurav	D	8/2/2013	
274	Mukadam	Dilip Chandrkant Jogamekar	D	8/2/2013	
275	Carpenter II	Arun Bhikaji Mistri	D	3/5/1979	
276	Painter III	Sanjay Gangaram Sakpal	D	9/12/2004	
277	Painter II	Pradeep Hanumant Labdhe	D	4/3/2004	

Section 4(1) (b) (x)

Details of remuneration of officers and employees in the office of Assistant Engineer (Maintenance & Repair)
K/East ward

SR NO	DESIG-SIGNA-NATION	EMPLOYEE NAME	GRD	BASIC	GRP	DA	WC	CA	SPA	TA	MMA	HRA	P D A	UWA	H S	I	NT D	AA P	EXT	TOTAL SALARY
SR NO	DESIG-SIGNA-NATION	EMPLOYEE NAME	GRD	BASIC	GRP	DA	WC	CA	SPA	TA	MMA	HRA	P D A	UWA	H S	I	NT D	AA P	EXT	TOTAL SALARY
1	Asst. Eng	Ghalsashi Milind Mukund	B	24570	5400	29970		463		1600	200	8991								71194
2	Asst. Eng	Bodkhe Umesh C	B	25110	5400	30510		1400		1600	200	9163								73373
3	Sub Eng	Sonawane Namrata Sub-hash	B	12540	4600	17140		463		1200	200	5142								41285
4	Sub Eng	Rajas Rohit Vishwanath	B	13460	4600	18060		463		1200	200	5418								43401
5	Sub Eng	Gurao Rajiv Balkrishna	B	22030	4600	26630		463		1200	200	7989								63112
6	Sub Eng	Patil Ranjit Hindurao	B	12460	4600	17060		463		1200	200	5118								41101
7	Sub Eng	Kale Amit Vijay	B	12540	4600	17140		463		1200	200	5142								41285
8	Sub Eng	Pandey Rakesh Mahatam	B	13060	4600	15894		463		1200	200	5291								40715
9	Jr. Eng	Dhende Vishwas Appasaheb	C	10100	4300	14400		463		600	200									30063
10	Jr. Eng	Sarwade Sachin Laxmanrao	C	11020	4300	15320		463		600	200	4596								36499
11	Jr. Eng	Jadhav Archana Shrikant	C	12420	4300	16720		463		600	200	5016								39719
12	Jr. Eng	Kulkarni Santosh	C	12420	4300	16720		463		600	200	5016								39719
13	Jr. Eng	Narkar Nilesh Ganpat	C	12420	4300	16720		463		600	200	5016								39719
14	Jr. Eng	Jadhav Nitesh Ramchandra	C	12420	4300	16720		463		600	200	5016								39719
15	Jr. Eng	Girgonkar Ramesh Gangaram	C	11930	4300	16230		463		600	200	4869								38592
16	Jr. Eng	Jadhav Milind Raghunath	C	11930	4300	16230		463		600	200	4869								38592
17	Jr. Eng	Khedkar Amol Pandurang	C	10990	4300	15290		463		600	200	4587								36430
18	Jr. Eng	Bos Kunal Dnyaneshwar	C	10100	4300	14400		463		600	200	4320								34383
19	Jr. Eng	Kamble Kiran Ramrao	C	10100	4300	14400		463		600	200	4320								34383
20	Jr. Eng	Deshmukh Pallavi P	C	10100	4300	14400		463		600	200	4320								34383
21	Jr. Eng	Yadav Yattatrya Dilip	C	10100	4300	14400		463		600	200	4320								34383
22	Jr. Eng	Danole Tushar Jivandhar	C	10100	4300	14400		463		600	200	4320								34383
23	Jr. Eng	Dalavi Nisha Vikas	C	12420	4300	16720		463		600	200	5016								39719
24	Store Clerk	Pedhnekar Sanjay Namdeo	C	11900	2000	13900				600	200	4170								32770
25	Labourer	Sabna Tayappa Dhangar	D	11250	1800	13050	115			600	200	3915								30930
26	Labourer	Shanker Badri-das	D	11010	1800	12810	115			600	200	3843								30378
27	Labourer	Aanna Sakhar-ram Pawar	D	11140	1800	12940	115			600	200	3882								30677
28	Labourer	Ashok Hari Sawant	D	11140	1800	12940	115			600	200	3882								30677
29	Labourer	Chotalal Murlee Bairagee	D	11140	1800	12940	115			600	200	3882								30677
30	Labourer	Dharmraj Sukhlal Bairagee	D	11140	1800	12940	115			600	200	3882								30677
31	Labourer	Shridhar Ni-vruktii Kedar	D	11140	1800	12940	115			600	200	3882								30677
32	Labourer	Vilas Masku Shinde	D	11010	1800	12810	115			600	200	3843		300						30678
33	Labourer	Mohan Kachur Rokade	D	11140	1800	12940	115			600	200	3882		300						30977
34	Labourer	Suresh Sawala Jadhav	D	11530	1850	13380	115			600	200	4014			636					32325

115	Labourer	Ganesh Govind Gaikwad	D	10290	1800	12090	115			600	200	3627		300					29022	
116	Labourer	Laxmi Parshuram Kase	D	10350	1800	12150	115			600	200	3645							28860	
117	Labourer	Periswami Nach Dewar	D	9980	1800	11780	115			600	200	3534		300					28309	
118	Labourer	Gurunath Raghunath Khaire	D	9980	1800	11780	115			600	200	3534							28009	
119	Labourer	Prakash manakya Kambale	D	9980	1800	11780	115			600	200	3534							28009	
120	Labourer	Sunil Shivdas Narayane	D	9980	1800	11780	115			600	200	3534		300					28309	
121	Labourer	Pravin Anant Bhosale	D	9980	1800	11780	115			600	200	3534							28009	
122	Labourer	Velayuttham Shrirangan Kuppaswami	D	9630	1800	11430	115			600	200	3429		300					27504	
123	Labourer	Deepak Tukaram Jadhav	D	9980	1800	11780	115			600	200	3534							28009	
124	Labourer	Sureshkumar Chimanlal Mitna	D	10180	1800	11980	115			600	200	3594							28469	
125	Labourer	Muralidhar Devrao Jogdande	D																	
126	Labourer	Jaywant Ramchandra Shinde	D	10180	1800	11980	115			600	200	3594		300					28769	
127	Labourer	Suhas Vasudev Kubal	D	9730	1800	11530	115			600	200	3459							27434	
128	Labourer	Ravindra Shankar Vichare	D	10180	1800	11980	115			600	200	3594		300					28769	
129	Labourer	Tuashiram Mahadev Tapase	D	10180	1800	11980	115			600	200	3594		300					28769	
130	Labourer	Prakash Vishram Velaye	D	10180	1800	11980	115			600	200	3594		300					28769	
131	Labourer	Ramdas Mhasku Shinde	D	9830	1800	11630	115			600	200	3489		300				846	28810	
132	Labourer	Bhivchand Bhaga Pandit	D	10180	1800	11980	115			600	200	3594						559	##	29928
133	Labourer	Umesh Pandhari Kankonkar	D	10180	1800	11980	115			600	200	3594								28469
134	Labourer	Mahadev Krishnaji Bandkar	D	10180	1800	11980	115			600	200	3594		300						28769
135	Labourer	Chandrakant Babu Hatpale	D	10180	1800	11980	115			600	200	3594								28469
136	Labourer	Gajendra Nathuram Vanjare	D	10180	1800	11980	115			600	200	3594								28469
137	Labourer	Nanda Mhasku Shinde	D	9830	1800	11630	115			600	200	3489								27664
138	Labourer	Subhash Babu Narayane	D																	
139	Labourer	Krishnakumar Prabhuram Chavaria	D	10180	1800	11980	115			600	200	3594		300						28769
140	Labourer	Rajendra Rama Shejwal	D	9510	1800	11310	115			600	200	3393								26928
141	Labourer	Nazir Husain Alibhai Shaikh	D	10180	1800	11980	115			600	200	3594		300						28769
142	Labourer	Baijnath Rajitram Pandye	D	10180	1800	11980	115			600	200	3594		300						28769
143	Labourer	Surendra Govind Korlekar	D	10180	1800	11980	115			600	200	3594		300						28769
144	Labourer	Narayan Yelappa Pawar	D	10180	1800	11980	115			600	200	3594		300						28769
145	Labourer	Kantaram Krishna Keni	D	10180	1800	11980	115			600	200	3594		300						28769
146	Labourer	Sitaram Krishna Thik	D	10180	1800	11980	115			600	200	3594								28469
147	Labourer	Dilip Aatmaram Chavan	D	10180	1800	11980	115			600	200	3594								28469
148	Labourer	Krishna Vishram Sawant	D	10180	1800	11980	115			600	200	3594							609	29078
149	Labourer	Rameshchandra Kisan Rathod	D	10180	1800	11980	115			600	200	3594								28469
150	Labourer	Madhukar Kerba Patil	D	10180	1800	11980	115			600	200	3594		300						28769
151	Labourer	Ashok Sahebrav Sonavane	D	10180	1800	11980	115			600	200	3594								28469

189	Labourer	Posamalla Gatayya Elgam	D	9850	1800	11650	115			600	200	3495		300						28010
190	Labourer	Satyavan Kashiram Manjarekar	D	9850	1800	11650	115			600	200	3495		300						28010
191	Labourer	Ashok Sunkap- pa Kadar	D	7610	1300	8910	75			600	200	2673		200						21568
192	Labourer	Yellappa Gan- garam Andredy	D	9980	1800	11780	115			600	200	3534		300						28309
193	Labourer	Shantaram Devram Dhin- dale	D	6330	1800	8130	115			600	200	2439								19614
194	Labourer	Balu Bhiva Bhangare	D	6430	1800	8230	115			600	200	2469		300						20144
195	Labourer	Umesh Eknath Chavan	D	6330	1800	8130	115			600	200	2439								19614
196	Labourer	Sitaram Laxman Shengal	D	6330	1800	8130	115			600	200	2439		300						19914
197	Labourer	Eknath Kaluram Bhoir	D	6330	1800	8130	115			600	200	2439		300						19914
198	Labourer	Prakash Radkya Bhoir	D	6330	1800	8130	115			600	200	2439		300						19914
199	Labourer	Sanjay Ram- chandra Amte	D	6330	1800	8130	115			600	200	2439		300						19914
200	Labourer	Sandeep Baban Patil	D	6330	1800	8130	115			600	200	2439								19614
201	Labourer	Kishor Raman Macchi	D	6330	1800	8130	115			600	200	2439								19614
202	Labourer	Sanjay Vinayak Patil	D	6330	1800	8130	115			600	200	2439								19614
203	Labourer	Nitinkumar Jaannath Chaudhari	D	6330	1800	8130	115			600	200	2439		300						19914
204	Labourer	Dattatray Vasu- dev Kini	D	6330	1800	5130	115			600	200	2439		300						19914
205	Labourer	Pankaj Govind Gavad	D	6330	1800	8130	115			600	200	2439								19614
206	Labourer	Vishal Kamalakar Choudhari	D	6330	1800	8130	115			600	200	2439								19614
207	Labourer	Surendra Aasaram Male- var	D	6330	1800	8130	115			600	200	2439								19614
208	Labourer	chandrakant Babu Hatpale	D	6330	1800	8130	115			600	200	1800								18975
209	Labourer	Mahadev Rohidas Sur- wase	D	6330	1800	8130	115				200	2439		250						19264
210	Labourer	Dnyaneshwar Bapurao Ba- gade	D	6090	1800	7890	115			1200	200	2367								19662
211	Labourer	Sandeep Dadu Patil	D	5860	1800	7660	115			600	200	2298								18533
212	Labourer	Rameshchandra Radheshyam Yadav	D	5860	1800	7660	115			1200	200	2298								19133
213	Labourer	Ganesh Anan- drao Sutar	D	5860	1800	7660	115			1200	200	2298								19133
214	Labourer	Sandip Shahu- raj Jogdandkar	D	5860	1800	7660	115			600	200	2298		200						18733
215	Labourer	Santosh Janap- pa Kadar	D	5630	1800	7430	115			600	200	2229								18004
216	Labourer	Girish Laxmi- man Makvana	D	5630	1800	7430	115			600	200	2229								18004
217	Labourer	Vilas Rama Bhoir	D	5630	1800	7430	115			600	200	2229								18004
218	Labourer	Anaji Govind Gode	D	5630	1800	7430	115			600	200	2229								18004
219	Labourer	Gorakha Gan- garam Khade	D	5630	1800	7430	115			600	200	2229		300						18304
220	Labourer	Ramesh Chan- drakant Kadam	D	4800	1300	6100	115			600	200	1830								14945
221	Labourer	Vilas Tulasiram Ghane	D	5630	1800	7430	115			600	200	2229		300						18304
222	Labourer	Dattatray Vittal Zole	D	4820	1300	6120	115			600	200	1836		300						15291
223	Labourer	Yusuf Ismail Tadavi	D	4800	1300	6100	115			600	200	1830		300						15245
224	Labourer	Bajirao Datta- tray Kunde	D	4800	1300	6100	115			600	200	1830								14945

225	Labourer	Dinesh Sudha- kar Shejval	D	5630	1800	7430	115			600	200	2229							18004
226	Labourer	Satish Bhimrao Gotis	D	4800	1300	6100	115			600	200	1830							14945
227	Labourer	Ramesh Sakha- ram Dagale	D	5630	1800	7430	115			600	200	2229		300					18304
228	Labourer	Ganesh Maha- du Kunde	D	5630	1800	7430	115			600	200	2229		300					18304
229	Labourer	Pradip Dinkar Pote	D	5860	1800	7660	115			600	200	2298							18533
230	Labourer	Rohidas Sakha- ram Ugale	D	4800	1300	6100	115			600	200	1830		300					15245
231	Labourer	Shivaji Tukaram Mali	D	5630	1800	7430	115			600	200	2229							18004
232	Labourer	Laxman Kondu Lohkare	D	4990	1300	6290	115			600	200	1887		300					15682
233	Labourer	Gopinath Ma- hadu Bhoir	D	5630	1800	7430	115			600	200	2229							18004
234	Labourer	Nivarutti Bhima Lande	D	5630	1800	7430	115			600	200	2229							18004
235	Labourer	Ashok Vana More	D	5630	1800	7430	115			600	200	2229		300					18304
236	Labourer	Sandeep Lavu Bhatle	D	4620	1300	5920				600	200	1776		300					14716
237	Labourer	Santosh Yellan- na Dhotre	D	4620	1300	5920				600	200	1776		300					14716
238	Labourer	Raju Parshuram Shilvant	D	4620	1300	5920				600	200	1776		300					14716
239	Labourer	Marugavel Tangrajan	D	4620	1300	5920				600	200	1776		300					14716
240	Labourer	Bharat Shyam kunchikovare	D	4620	1300	5920				600	200	1776		300					14716
241	Labourer	Ganesh Chan- drakant Man- davkar	D	4440	1300	5740				600	200	1722							14002
242	Labourer	Ingave Bhag- wan Kisan	D	11530	1850	13380	115			600	200	4014							31689
243	Labourer	Rokade Dharma Dadarao	D	10580	1850	12430	115			600	200	3729		300					29804
244	Mistry II	Kush Vankatesh Kankonkar	D	11770	1900	13670	115	463		600	200	4101							32819
245	Mistry II	Babasaheb Damu Magade	D	11770	1900	13670	115	463		600	200	4101							32819
246	Mistry II	Duryodhan Dhakappa Bhorkade	D	11770	1900	13670	115	463		600	200	4101							32819
247	Mistry II	Laxman Shan- kar Bilaskar	D	11770	1900	13670	115	463		600	200	4101							32819
248	Mason II	Siddharth Keru Sawant	D	11090	1900	12990	115			600	200	3897							30792
249	Mukadam	Mohan Dudha- ba Inkar	D	11770	1900	13670	115	463		600	200	4101		190					33009
250	Mukadam	Maruti Mukund More	D	11350	1850	13200	115	463	-	600	200	3960	-	190	-	-	-	-	31928
251	Mukadam	Gokul Dattatray Buwa	D	11570	1900	13470	115	463		600	200	4041		190					32549
252	Mukadam	Kashinath Lahanu Borade	D	11350	1850	13200	115	463	-	600	200	3960	-	190	-	-	-	-	31928
253	Mukadam	Chandrakant Gopal Wagha- mare	D	11170	1850	13020	115	463	-	600	200	3906	-	190	697	-	-	-	32211
254	Mukadam	Chandrakant Krishna Vaiti	D	10750	1850	12600	115	463	-	600	200	3780	-	190	-	-	-	-	30548
255	Mukadam	Yashwant Dhondu Shinde	D	11170	1850	13020	115	463		600		3906		190	463				31514
256	Mukadam	Sopan Kushaba Supe	D	10340	1850	12190	115	463	-	600	200	3657	-	190	382				29987
257	Mukadam	Chandrakant Vitthal Burud	D	10340	1850	12190	115	463		600	200	3657							29415
258	Mukadam	Ganpat Soma Karbele	D	11530	1850	13380	115			600	200	4014							31689
259	Mukadam	Sitaram Raja- ram Gurav	D	11530	1850	13380	115			600	200	4014							31689
260	Mukadam	Dilip Chandrakant Jogamekar	D	11530	1850	13380	115			600	200	4014							31689
261	Carpenter II	Arun Bhikaji Mistri	D																

262	Painter III	Sanjay Ganga- ram Sakpal	D	10710	1900	12610	115			600	200	3783							29918
263	Painter II	Pradeep Hanu- mant Labdhe	D	11460	1900	13360	115			600	200	4008							31643
264	Hamal	Ramchandra Sitaram Chavan	D	11140	1800	12940	115			600	200	3882			581				31258
265	Hamal	Dattaram Babu Hatpale	D	11410	1850	13260	115			600	200	3978							31413
266	Hamal	Shantaram Rama Hatpale	D	11410	1850	13260	115			600	200	3978							31413
267	Labourer C Watch- man	Suraj Babulal Bairagi	D	10180	1800	11980	115			600	200	3594							28469
268	Labourer C Watch- man	Maruti Rajaram More	D	10180	1800	11980	115			600	200	3594							28469
269	Labourer C Watch- man	Ganesh Sudam Tapkir	D	10340	1850	12190	115			600	200	3657							28952
270	Labourer C Watch- man	Anant Bhiku Narvekar	D	10820	1800	12620	115			600	200	3786							29941
271	Labourer C Watch- man	Suresh Mariba Gaikwad	D	11090	1850	12940	115			600	200	3882			704				31381
272	Labourer C Watch- man	Dagadu Ragu Bodake	D	10960	1850	12810	115			600	200	3843							30378
273	Labourer C Watch- man	Girjashankar S Mishra	D	10960	1850	12810	115			600	200	3843							30378
274	Labourer C Watch- man	Prafulla Motiram Manchekar	D	11040	1850	12890	115			600	200	3867							30562
275	Labourer C Watch- man	Chinnamuttu Armugan Dewar	D	10780	1800	12580	115			600	200	3774							29849
276	Liftman C Wirmen C Plumber	Raut Sandesh Prakash	D	10340	1900	12240	115			600	200	3672							29067
277	Liftman C Wirmen C Plumber	Solanki Govind Jadhav	D	9980	1900	11880	115			600	200	3524							28239

Section 4 (1) (b) (xi)

Details of allocation of budget and disbursement made in the office of Assistant Engineer (Maintenance & Repairs) K/East Ward for the year 2013-2014

Sr. No	Budget Head Description	Grants received (In Lakhs)	Planned use (give details area wise or work wise in a separate form)	Remarks
1	Unforeseen Grant Beat No. 66	60.00	59.86	
2	Unforeseen Grant Beat No. 67	60.00	59.98	
3	Unforeseen Grant Beat No. 68	60.00	59.99	
4	Unforeseen Grant Beat No. 69	60.00	59.51	
5	Unforeseen Grant Beat No. 70	60.00	59.99	
6	Unforeseen Grant Beat No. 71	60.00	59.99	
7	Unforeseen Grant Beat No. 72	60.00	59.97	
8	Unforeseen Grant Beat No. 73	60.00	52.96	
9	Unforeseen Grant Beat No. 74	60.00	59.99	
10	Unforeseen Grant Beat No. 75	60.00	59.65	
11	Unforeseen Grant Beat No. 76	60.00	59.73	
12	Unforeseen Grant Beat No. 77	60.00	60.00	
13	Unforeseen Grant Beat No. 78	60.00	58.00	
14	Unforeseen Grant Beat No. 79	60.00	54.57	
15	Unforeseen Grant Beat No. 80	60.00	60.00	
16	Development of Gaothan in K/East Ward	25.00	15.57	

17	General Civil Repairs - Administrative Building	8.5	8.5	
18	Integrated adiwasi Pada	49.00	48.97	
19	repairs to Marol Fire Station	55.00	23.99	
20	General Civil Repairs - School	NIL	NIL	
21	General Civil Repairs - School (Rent)	NIL	NIL	
22	General Civil repairs street light post	43.00	43.00	
23	General Civil repairs road & pavement slum	292.45	281.00	
24	Gen.Civil Repairs Public Toilet PSC Block	430.8	378.33	
	Total	1801.75	1680.38	

Form B for previous year

Sr. No	Budget Head Description	Grants received (In Lakhs)	Grant utilized	Grants Surrendered	Remarks
1	Unforeseen Grant Beat No. 66	60.00	52.06		
2	Unforeseen Grant Beat No. 67	60.00	59.93		
3	Unforeseen Grant Beat No. 68	60.00	59.17		
4	Unforeseen Grant Beat No. 69	60.00	59.76		
5	Unforeseen Grant Beat No. 70	60.00	53.97		
6	Unforeseen Grant Beat No. 71	60.00	59.30		
7	Unforeseen Grant Beat No. 72	60.00	58.36		
8	Unforeseen Grant Beat No. 73	60.00	53.77		
9	Unforeseen Grant Beat No. 74	60.00	57.63		
10	Unforeseen Grant Beat No. 75	60.00	57.00		
11	Unforeseen Grant Beat No. 76	60.00	59.96		

12	Unforseen Grant Beat No. 77	60.00	58.63		
13	Unforseen Grant Beat No. 78	60.00	53.32		
14	Unforseen Grant Beat No. 79	60.00	33.54		
15	Unforseen Grant Beat No. 80	60.00	49.50		
16	Development of Gaothan in K/East Ward	25.00	25.00		
17	General Civil Repairs - Adminitrative Building	8.5	8.5		
18	Integrated adiwasi Pada	49.00	25.00		
19	repairs to Marol Fire Station	NIL	NIL		
20	General Civil Repairs - School	NIL	NIL		
21	General Civil Repairs - School (Rent)	NIL	NIL		
22	General Civil repairs street light post	30.00	30.00		
23	General Civil repairs road & pavement slum	292.45	281.00		
24	Gen.Civil Repairs Public Toilet PSC Block	430.8	378.33		
25	Ward Committee	600.00	572.16		
	Total	1646.25	0.00		

Section 4(1)(b)(Xii)

Manner of execution of subsidy program in the office of Assistant Engineer (Maintenance and Repair)

Sr. No.	Name And Address of Beneficiary	Amount of Subsidy/Concession Sanctioned
1	NIL	NIL

Section 4(1)(b)(Xiii)

**Particulars of recipients of concessions, permits or authorizations granted in the office of Assistant Engineer
(Maintenance and Repair)**

Sr.No.	Name of the License	License No	Issued On	Valid Up to	General Condittions
1	NIL	NA	NA	NA	NA

Section 4(1)(b)(xiv)

Details of information available in electronic form in the office of Assistant Engineer (Maintenance and Repair)

Sr.No.	Type of Documents file/Register	Sub Topic	In Which Electronic format it is kept	Person in Charge
1	Various External Utility Trench permission	Permit/Purchase order for execution of work	It is on SAP system and displayed on MCGM Portal	Ward Executive Engineer K/East Ward and Asstt. Engineer Maint.1&2
2	E-Tendering and CWC Work	Purchase Order/Payment Certificate of Various Work in k/East Ward	It is on SAP system and displayed on MCGM Portal	Ward Executive Engineer K/East Ward and Asstt. Engineer Maint.1&2
3	Religious /Shooting Permission	Permit	It is on SAP system and displayed on MCGM Portal	Ward Executive Engineer K/East Ward and Asstt. Engineer Maint.1&2

Section 4(1)(b)(xv)

Particulars of facilities for citizen for obtaining information in the office of Assistant Engineer (Maintenance & Repair)

Types of facilities -

Information about facilities for inspection of record

Sr. No	Type of Facility	Timings	Procedure	Location	Person in charge
1	Inspection of Record	3.00 p.m. to 5.00 pm on Tuesday and Thursday (except holidays) with prior appointment only.	For inspection of records no fee for first hours will be charged however fee of Rs .5 /- for each 15 minutes or fraction thereof will be charged thereafter.	Office of Asstt. Engineer , maintenance Department , Room No. 101, First Floor, K/East Office, Azad Road, Gundavali , Andheri East Mumbai - 400069.	Asstt. Engineer , maintenance , K/East Ward

Section 4(1)(b)(xv)

Details of public information officers / APIO's / appellate authority in the jurisdiction of (Public authority) in the office of Assistant Engineer (Maintenance & Repairs)

Sr. No	Name of PIO	Designation	Jurisdiction as PIO under RTI	Address / Ph. No	Email id for purpose of RTI	Appellate authority
1	Shri. Milind Ghalsasi	Asstt. Engineer (Maint) I	Electrol ward no. 72,75,76,77,78,79,80	Maintenance Department , Room No. 101, First Floor, K/East Office, Azad Road, Gundavali , Andheri East Mumbai - 400069. Contact No- 022-26834485 Ext no.328		Shri. Chandrashekhar Marathe, Ex. Engineer K/East Ward, K/East Ward, Third Floor, Room no. 301 ,Gundavali , Azad Road, Andheri East Contact No- 022-26834485 Ext no.211
2	Shri. Umesh Bodkhe	Asstt. Engineer (Maint) II	Electrol ward no. 66 ,67,68,69,70,71,73,74	Maintenance Department , Room No. 101, First Floor, K/East Office, Azad Road, Gundavali , Andheri East Mumbai - 400069. Contact No- 022-26834485 Ext no.324		Shri. Chandrashekhar Marathe, Ex. Engineer K/East Ward, K/East Ward, Third Floor, Room no. 301 ,Gundavali , Azad Road, Andheri East Contact No- 022-26834485 Ext no.211

Section 4(1)(b)(xv)

**Details of public information officers / APIO's /appellate authority in jurisdiction of (Public authority)
in the office of Assistant Engineer (Maintenance)**

APIOs

Sr. No	Name of PIO	Name of APIO	Designation	Jurisdiction as APIO under RTI	Address / Ph. No.
1	Shri. Umesh Bodkhe (Asstt.Eng.Maint.II)	Shri Rakesh M.Pandey	Sub.Eng./Road Engineer	Information regarding the various work including road work of beat no 66,69 & 71	Contact No- 022- 26834485
2	Shri. Umesh Bodkhe (Asstt.Eng.Maint.II)	Shri Amit Kale	Sub.Eng./Road Engineer	Information regarding the various work including road work of beat no 67,68 & 70	Contact No- 022- 26834485
3	Shri. Umesh Bodkhe (Asstt.Eng.Maint.II) Shri. Milind Ghalsasi (Asstt.Eng.Maint.I 75)	Shri Rohit Rajas	Sub.Eng./Road Engineer	Information regarding the various work including road work of beat no 73,74 & 75	Contact No- 022- 26834485
4	Shri. Milind Ghalsasi (Asstt.Eng.Maint.I)	Shri Rajiv Gurav	Sub.Eng./Road Engineer	Information regarding the various work including road work of beat no 77,79 & 80	Contact No- 022- 26834485
5	Shri. Milind Ghalsasi (Asstt.Eng.Maint.I)	Shri Ranjit Patil	Sub.Eng./Road Engineer	Information regarding the various work including road work of beat no 72, 76 & 78	Contact No- 022- 26834485

Section 4(1)(b)(xvi)

Details of public information officers /APIO's/ appellate authority in the jurisdiction of (public authority) in the office of Assistant Engineer (Maintenance)

Sr.No.	Name of Appellate Authority	Designation	Jurisdiction as Appellate authority	PIO Reporting	E mail id for purpose of RTI
1	Shri C.S. Marathe	Ward Ex.Engineer	K/East Ward	A.E.(Maintenance) K/East Ward	

Section 4 (1) (b) (xvii)

MAJOR ROADS IN K/EAST WARD

MAJOR ROADS IN K/East Ward					
Sr. No.	Road Name - K/E Ward	Road Length (m.)	Width of Road (m)	No. of Lanes	Total Lane Length (m)
1	Milan subway to service road	70	13.4	2	140
2	St Chokha Mela Path	200	13.4	2	400
3	Dayaldas Road	500	18.3	4	2000
4	dayaldas extension	800	27.4	6	4800
5	Nirman Cross Rd	111	13.4	2	222
6	N Patkar Marg	400	13.4	2	800
7	Nanda patkar extension	550	13.4	2	1100
8	Shrddhanand Road	720	18.3	4	2880
9	N P Thakkar Rd	360	13.4	2	720
10	P M Road	531	13.4	2	1062
11	V Makarand Ghanekar Rd	400	13.4	2	800
12	Azad road	745	18.3	4	2980
13	Nehru Road	930	18.3	4	3720
14	St Janabai Road	510	13.4	2	1020
15	Gujarat Society Path	471	18.3	4	1884
16	Dixit Road (North)	390	12.2	2	780
17	Malviya Road	683	12.2	2	1366
18	Mahatma Gandhi Rd	860	18.3	4	3440
19	Park Road (North)	275	13.4	2	550
20	Prarthana Samaj Road	660	12.2	2	1320
21	Kashibhuvan Dixit Rd	270	13.4	2	540
22	Malaviya X road	160	13.4	2	320
23	Chitranjan Road	290	13.4	2	580
24	Mahant Rd	440	12.2	2	880
25	14 th TPS road	312	18.3	4	1248
26	Monghibai Road	166	18.3	4	664
27	Parleshwar Rd	239	12.2	2	478
28	Tejapal Rd (station road)	329	18.3	4	1316
29	Hunuman Rd	940	18.3	4	3760
30	Paranjpe Scheme B rd no 1	268	18.3	4	1072
31	Subhash Road	1063	18.3	4	4252

32	Captain Vinayak Gore Marg	300	13.4	2	600
33	V S Khandekar Rd	359	18.3	4	1436
34	Shahaji Raje Rd	798	18.3	4	3192
35	Jeevan Vikas Kendra Marg	330	12.2	2	660
36	Sahar road	1100	27.4	6	6600
37	Jiva Mahale Rd	500	18.3	4	2000
38	Cardinal Gracious Road South side (Chakala Road)	460	18.3	4	1840
39	M C Chagla Road	520	18.3	4	2080
40	Ashok Chakravarti Road	500	18.3	4	2000
41	Tarun Bharat Soc. Road	550	18.3	2	1100
42	Shriniwas Bagarka Road (J. B. Nagar Road)	625	18.3	4	2500
43	Guru Hargovindji Road	1850	45.7	10	18500
44	Cardinal Gracious Road North side	350	18.3	4	1400
45	Prof N S Phadke Road upto W.E. Highway	710	36.6	8	5680
46	Teli Galli cross road	320	12.2	2	640
47	Teli Galli	445	18.3	4	1780
48	Police Quarter Lane	325	13.4	2	650
49	Sahar Road	1500	27.45	6	9000
50	Nehru Road	250	18.3	4	1000
51	Swami Nityanand Road	600	27.45	6	3600
52	S. Radhakrishna Road	190	18.3	4	760
53	S. Radhakrishna Cross Road	70	18.3	4	280
54	Gundavali Mun. School road	300	18.3	4	1200
55	Sahar Road	869	27.45	6	5214
56	Airport Road	725	27.45	6	4350
57	Mistry Complex Road	459	13.4	2	918
58	Off Bhagwan Mahavir Road	452	13.4	2	904
59	Om Nagar Road	150	13.4	2	300
60	Sahar Cross Road Between Hotels	331	13.4	2	662
61	Chimatpada Road	499	18.3	4	1996
62	Ruby Coach Road	865	18.3	4	3460
63	Ruby Coach Road	330	18.3	4	1320
64	Ruby Coach Road ext.	260	18.3	4	1040
65	I A Project Road	1399	27.45	6	8394
66	Mathurdas Vasanji Rd	2000	45.7	10	20000
67	Ruby Coach Cross Road 1	63	18.3	4	252
68	Ruby Coach Cross Road 2	45	18.3	4	180
69	Ruby Coach Cross Road 3	50	18.3	4	200
70	Gundawali road no-1	636	13.4	2	1272
71	Andheri Station Rd	457	18.3	4	1828
72	Parsi Panchyat Rd	578	13.3	4	2312
73	Nicholas wadi raod	606	18.3	2	1212
74	R K Paramhans Rd	336	18.3	4	1344

75	New Nagardas Rd	326	18.3	4	1304
76	Hindu Friends Society Rd/Amboli Falak Rd	925	27	4	3700
77	Hindu Friends Society Rd/Amboli Falak Rd	313	13.4	2	626
78	Hindu Friends Society Rd/Amboli Falak Rd	764	13.4	2	1528
79	Natwar Nagar Rd No 5 cross road	450	18.3	2	900
80	R K Singh Rd	572	18.3	2	1144
81	Subhash Nagar Rd	368	18.3	4	1472
82	Suren Rd	254	13.4	2	508
83	Malapa Dongari Marg/ datta mandir marg	733	18.3	4	2932
84	road no-2	192	10.05	2	384
85	road no-3	434	10.05	2	868
86	road no-4	171	10.05	2	342
87	road no-5	610	10.05	2	1220
88	Mahakali Caves Rd	753	18.3	6	4518
89	Mathurdas Vasanji Rd	1400	27.5	6	8400
90	vijay raut road	731	18.3	2	1462
91	R R Thakur Rd	390	13.4	2	780
92	Jogeshwari Vikroli Link Rd	1800	45.7	6	10800
93	Jogeshwari caves road	770	18.3	2	1540
94	Jijamata Jijabai Marg/vijay raut road		18.3	2	
95	D P road at beat no -66		18.3	2	
96	Natwar Nagar Rd No 1	559	18.3	2	1118
97	Natwar Nagar Rd No 5	563	13.4	2	1126
98	Rd No 11	734	13.4	2	1468
99	Cross Rd A	468	13.4	2	936
100	Cross Rd B	1160	13.4	2	2320
101	Rd No 8	188	13.4	2	376
102	Rd. connecting B cross rd. & Rd. no. 9	90	13.4	2	180
103	Rd No 9	268	13.4	4	1072
104	Rd.connecting MIDC central rd. & Rd. no11.	228	13.4	2	456
105	Rd No 22	490		4	1960
106	Cross Rd C	688	18.3	4	2752
107	cross rd. from MIDC C cross rd. to dead end.	159	18.3	4	636
108	MIDC Central Rd	1291	27.45	6	7746
109	Rd No 4	545	13.4	4	2180
110	Rd No 1	192	13.4	4	768
111	Rd No 2	202	13.4	4	808
112	Rd No 3	209	13.4	4	836
113	5 th Rd / Kondivita RamKriShna Mandir Rd	225	13.4	4	900
114	Rd No 16 / Kondivita Rd	1014	13.4	4	4056

115	Rd No 7	369	13.4	4	1476
116	Rd No 15	322	13.4	2	644
117	Rd No 17	129	13.4	2	258
118	Rd No 18	276	13.4	2	552
119	Rd No 13	414	13.4	4	1656
120	Rd connecting C cross rd. & Rd. no. 13	196	13.4	4	784
121	cross rd. from MIDC Rd. no. 16 to dead end.	156	13.4	2	312
122	Rd. no. 20	86	13.4	2	172
123	Marol Church rd.	188	13.4	2	376
124	Church Rd	508	13.4	2	1016
125	cross rd. from Marol maroshi rd. to dead end (starting from adjacent to Marol fire brigade)	173	13.4	2	346
126	Marol Maroshi Rd	1364	18.3	4	5456
127	Lokbharti rd.	336	18.3	4	1344
128	Mathurdas Vasanji Rd	1300	45.7	6	7800
129	Makawana Rd	612	18.3	4	2448
130	Marol Co-oprative Industrial Eastate	442	18.3	4	1768
131	Millitary Rd	769	13.4	4	3076
132	Millitary Rd (Saibaba Sagbaug Rd.)	531	18.3	4	2124
133	D P Rd, (Military Rd. Ext.)	673	18.3	4	2692
134	Guru Govind Singh Marg	828	18.3	4	3312
135	Sardar Vallabhai Patel Marg / Mahakali Caves Rd	1215	13.4	4	4860
136	Jogeshwari Vikroli Link Rd	3000	27.45	6	18000
137	M H B Colony Rd	360	13.4	2	720
138	Vijay Raut to GGS marg Jn.	690	18.3	2	1380
139	Shivaneri Vasahat Rd	797	18.3	2	1594
140	Pipeline Rd.	565	13.4	2	1130
141	Mahakali Caves Rd	1800	18.3	2	3600
142	MIDC Central Rd	960	27.45	4	3840
143	Marol Maroshi Rd	300	13.4	4	1200
144	Cross Rd. C	985	13.4	2	1970

LIST OF Minor ROADS IN 'K/East' WARD

Sr. No.	Road Name - K/E Ward	Road Length (m.)	Width of Road (m)	No. of Lanes	Total Lane Length (m)
1	Nirman Rd	400	9.15	2	800
2	Dixit road South	518	9.15	2	1036
3	Tenth (X) road	195	9.15	2	390
4	Sradhanand X road no2		9.15		
5	N.P.Thakkar X road	281	9.15	2	562
6	N.P.Thakkar X road extension	134	9.15	2	268
7	P.M. X road	200	9.15	2	400
8	Dixit X road no1	204	9.15	2	408
9	Play Ground Road	133	9.15	2	266
10	A Sawant Marg	260	9.15	2	520
11	A.Sawant X road	62	9.15	2	124
12	Chitrakar Ketkar road	129	9.15	2	258
13	Gokhale Road	150	9.15	2	300
14	Mahatma Phule road	154	9.15	2	308
15	Park road (south)	160	9.15	2	320
16	Azmal road	65	7.15	2	130
17	Azmal X road	130	7.15	2	260
18	Ram Mandir X Road	100	9.15	2	200
19	Ram Mandir Road (North)	187	9.15	2	374
20	Ram Mandir Road (S)	175	9.15	2	350
21	Tilak Mandir Road	410	9.15	2	820
22	Hanuman X road No 1	190	9.15	2	380
23	X to Hanuman Xroad no1	200	9.15	2	400

24	Mahant road (S)	191	9.15	2	382
25	Prathna samaj X road	109	9.15	2	218
26	Janabai X road no 1	97	9.15	2	194
27	Malviya Extention road	245	9.15	2	490
28	Ram Mandir X Road	185	9.15	2	370
29	M.G. X road no1	92	9.15	2	184
30	Paranjpe schem B rd no 3	185	9.15	2	370
31	Paranjpe schem B rd no 4	185	9.15	2	370
32	Paranjpe Scheme B rd No 2	182	9.15	2	364
33	Hunuman Cross Rd 2	252	9.15	2	504
34	Ext. Padloskar road	60	9.15	2	120
35	Pandioskar Marg	400	9.15	2	800
36	Taipal Scheam Road No 1	121	9.15	2	242
37	Taipal Scheam Road No 2	290	9.15	4	1160
38	Taipal Scheam Road No 3	251	9.15	2	502
39	Taipal Scheam Road No 4	249	9.15	2	498
40	Taipal Scheam Road No 5	246	9.15	2	492
41	Taipal Scheam Road No 5 X	100	9.15	2	200
42	Tilak Vidyalaya marg	130	9.15	2	260
43	Thanawala road	226	9.15	2	452
44	Ramabai X road no1	120	9.15	2	240
45	Thanawala X road	251	9.15	2	502
46	Ramabai Chemburkar road	130	9.15	2	260
47	Paranjpe schem A road no 1	110	9.15	2	220
48	Paranjpe A Scheam Rd3	161	9.15	2	322
49	Paranjpe A Scheam Rd 2	110	9.15	2	220
50	Captain Gore Flyover	141	9.15	2	282

51	Indulkar Rd	181	9.15	2	362
52	Baji Prabhu Deshpande Marg	377	9.15	2	754
53	Sahakar road	242	9.15	2	484
54	Sahakar X road no 1	100	9.15	2	200
55	Tukaram Sandam& X road	240	9.15	2	480
56	Sahaji raje X road no1	300	9.15	2	600
57	Sai Mandir Rd	200	9.15	2	400
58	Sai mandir X road	200	9.15	2	400
59	Jeevan Vikas X road	200	9.15	2	400
60	Koldongari Lane No. 2	160	4	1	160
61	Koldongari cross Rd (Kanhoji Aangre Rd) from Lane 1 to Jiva Mahale Rd	300	9.15	2	600
62	Koldongari Lane No. 1	400	9.15	2	800
63	Parsi Wada Rd	170	9.15	2	340
64	Prof N S Phadke Cross Road (South side)	110	9.15	2	220
65	Airport Road	2015	P	2	4030
66	Private Road (AAI Road)	203	P	2	406
67	M C Chagla Road (Airport Authority Road)	1300	P	2	2600
68	Air India Colony Internal Road	521	P	2	1042
69	Air India Colony Internal Road	315	P	2	630
70	Velankani Road	120	5	2	240
71	Air India Colony Internal Road	177	P	2	354
72	Airport Colony Internal Road	330	P	2	660
73	Airport Colony Internal Road	582	P	2	1164

74	Airport Colony Internal Road	170	P	2	340
75	Airport Colony Internal Road	330	P	2	660
76	Bamanwada Road (M C Chagla cross Road)	170	9.15	2	340
77	Bamanwada cross Road	110	9.15	2	220
78	P & T Colony Rd No 1	132	P	2	264
79	P & T Colony Rd No 2	108	P	2	216
80	P & T Colony Rd No 3	152	P	2	304
81	P & T Colony Rd No 4	211	P	2	422
82	P & T Colony Rd No 5	269	P	2	538
83	P & T Colony Rd No 6	187	P	2	374
84	Deolwadi Road	225	9.15	2	450
85	Private Road (Deolwadi cross Road)	155	P	2	310
86	Private Road (Tarun bharat cross Road on South side)	50	P	2	100
87	Tarun Bharat School Road	370	9.15	2	740
88	Tarun Bharat School cross Road	100	9.15	2	200
89	Private Road (Akal Soc. Internal Road)	202	P	2	404
90	Wireless Rd	185	9.15	2	370
91	Charat singh road (North side)	500	9.15	2	1000
92	Charat singh road (South side)	150	9.15	2	300
93	Minor Road Near Jai Mata Mandir	200	6	2	400
94	Court Lane	210	6	2	420
95	Cross road to Andheri Kurla on South side	360	9.15	2	720
96	Gundavali Mun. School cross road	250	9.15	2	500

97	Loop Road	250	9.15	2	500
98	P & T Colony 1	173	pvt	2	346
99	P & T Colony 2	214	pvt	2	428
100	P & T Colony 3	164	pvt	2	328
101	P & T Colony 4	405	pvt	2	810
102	Sheth Bhavanidas Benani Marg	361	pvt	4	1444
103	J B Nagar No 1	102	pvt	4	408
104	J B Nagar No 2	314	pvt	2	628
105	J B Nagar No 3	98	pvt	2	196
106	J B Nagar No 4	101	pvt	2	202
107	J B Nagar No 5	103	pvt	2	206
108	J B Nagar No 6	106	pvt	2	212
109	J B Nagar No 7	108	pvt	2	216
110	J B Nagar No 8	112	pvt	2	224
111	J B Nagar No 9	154	pvt	2	308
112	J B Nagar No 10	87	pvt	2	174
113	Church Pakadi Slum Road	392	pvt	2	784
114	Church Pakadi road no 1	440	9.15	2	880
115	Church Pakhadi Road cross	101	9.15	2	202
116	Church Pakadi main road	210	9.15	2	420
117	Cargo Cross	694	p	2	1388
118	Airport approach Road	837	pvt	2	1674
119	Sahar Road Cross road	887	9.15	2	1774

120	Bhavani Mahavir Marg	351	9.15	2	702
121	J B Nagar No 11	71	pvt	2	142
122	Airport Private road 1	685	pvt	4	2740
123	Airport Private road 2	263	pvt	2	526
124	Airport Private road 3	349	pvt	2	698
125	Airport Private road 4	425	pvt	2	850
126	Marol PipeLine	1048	9.15	2	2096
127	Avenue Road	378	9.15	2	756
128	ChimatPada Cross Road	183	6	2	366
129	Miltal Internal Road	175	9.15	2	350
130	Miltal Internal Road	304	9.15	2	608
131	Church Pakadi road no 1 cross road	75	3	2	150
132	Church Pakadi road no 1 cross road 2	198	3	2	396
133	Gundawali road no-2	266	5.4	2	532
134	D P Connecting M V Road With Rejency Hotel	475	9.15	2	950
135	Azad Rd	366	9.15	4	1464
136	chinoy college lane	408	9.15	2	816
137	Patel gully	354	9.15	2	708
138	Road no-1	149	9.15	2	298
139	cross road	295	9.15	4	1180
140	A N Tiwari road	229	9.15	4	916
141	Rameshwar Mandir marg	153	9.15	2	306
142	Mangal Mandap marg	230	8	2	460

143	Natwar Nagar Rd No 2	235	6	2	470
144	Natwar Nagar Rd No 4	241	6	2	482
145	Natwar Nagar cross road	149	7	2	298
146	Bandrekar wadi Road	572	6	2	1144
147	Hanjar road	721	7	2	1442
148	malpa dongri road no-1	265	4.7	2	530
149	malpa dongri road no-2	110	6	2	220
150	malpa dongri road no-3	227	8.7	2	454
151	road no-6	309	6	2	618
152	road no-7	136	5.4	2	272
153	road no-8	715	5.8	1	715
154	Majas Rd/Digambar Mhaskar Marg	326	8	2	652
155	Rd No 12	229		2	458
156	ESIS hospital internal road (private road)	545	9.15	2	1090
157	Private cross rd from B-cross road to industrial area (west side)	193	9.15	2	386
158	Private cross rd from B-cross road to industrial area (east side)	296	9.15	2	592
159	5 th Rd / Kondivita RamKriShna Mandir Rd	241	8	4	964
160	Rd No 19	145	9.15	2	290
161	Kadamwadi road	689	7	2	1378
162	Gaothan cross road from Chruch road to Masjid	114	8	2	228
163	Gaothan cross road from Chruch road to slum pocket	58	9	2	116
164	Marol Village Rd.	240	9	2	480
165	Marol Village Rd.	318	6	1	318

166	Marol Village Rd. connecting to church road	118	6	1	118
167	Cross road from marol maroshi road to slum pocket	259	7	2	518
168	Cross road from marol maroshi road to slum pocket connecting to slum internal rd.	165	7	2	330
169	Cross road from marol maroshi road to slum pocket dead end	214	9.15	2	428
170	Road adjacent to seven hills from marol maroshi rd. to slum pocket dead end	871	9	2	1742
171	Rd. connecting to Marol maroshi rd. & Makhwana rd.	309	9.15	2	618
172	Cross road from marol maroshi road to industrial area (private rd.)	208	9	2	416
173	Cross road from marol maroshi road to industrial area (private rd.)	96	9	2	192
174	cross rd. from Sagbaug rd. to dead end at mithi river	384	9.15	2	768
175	Millitary Rd	323	0	4	1292
176	D P Rd	265	8.5	2	530
177	D P Rd	288	8.5	2	576

List of Gardens, Playgrounds, Recreation Grounds, Open Spaces/Parks in K/East Ward

Sr. No.	Bea t No.	Name & Location of Garden/RG/PG/open space	Area in Sq.Mtr.	Reserva tion	Maintai ned by	Name of Agency	Tim Perio d	Existing Ammenities	Present Status	Remark
1	80	CTS No FP 521 TPS V, Garden plot at junction of Service road & Azad road near Milan subway, Vile Parle (E), Mumbai-57.	335	Garden	M.C.G. M	M.C.G. M.		Balwadi	Satisfac tory	
2	68	CTS No 169/4 & 168/9, SNo 42, H.No 2 (P) Poonam nagar near Ascent building majas Jogeshwari (E), Mumbai-60.	2154	Garden	M.C.G. M	M.C.G. M		Jogging Track, Gazibo, Security cabin	Good	MHADA Develop ment work in Progress
3	68	Caption Sandeep Unnikrishnan Udyan, CTS No 169/6-A & 169/7-B Kokan nagar Village Majas, Jogeshwari (E), Mumbai-60.	3926	Garden	M.C.G. M	M.C.G. M		Play App.,Mali Room, Jogging Track, Gazibo, Amphi Theater, Toilet.	Satisfac tory	P&D has develop ed plot. Needs improve ment.
4	73	CTS No. 244 B, Village Kondivita, Andheri (East)	131	Garden	M.C.G. M	M.C.G. M				
5	73	CTS No. 245 A(Pt), 179 (E) Village Mulgaon,M.I.D.C.,An dheri(E), Mumbai-99.	2153	Garden	M.C.G. M	M.C.G. M		Open Stage		Sant Nirankari Mandal maintain ing the Garden
6	69	Shree Sai Leela Udyan, CTS No. 382 (D),Vijay Raut Marg , Village Mogra ,Andheri (E), Mumbai-99.	367	Garden	M.C.G. M	M.C.G. M		Security Cabin	Fair	

7	68	Hemant Karkare Udyan, CTS No 168/7 & 171/3 S.No 42 H.No 2 (P) Village Majas & CTS NO 167 A part, A2 - G2, A1 - G3, C1 - G4, C3 - G5, Hissa No 2, Survey No 34 Village Majas, Poonam Nagar, near Kalpataru Enclave, Jogeshwari (E), Mumbai-60.	29686	Garden	M.C.G. M	K.B.A. Infrastru cture		Amphi Theater, Jogging Track, Drinking Water Facility,Toile t, Security cabin, Play App.	Good	Develope d & Maintain ed through P & D . Two Garden reservati on.
8	66	Chhatrapati Rajaram Maharaj Udyan, CTS no. 102 & 99(P) Tikka no 24 , at the junction of Caves Rd and western Express Highway, Jogeshwari (E), Mumbai-60	7835	Garden	M.C.G. M	Tirupati Enginee rs	15- Jan- 17	Gazibo, Jogging Track, Mali Chowky, Security Cabin	Good	Develope d & Maintain ed through P & D .
9	80	Nana Nani Park, CTS No FP 186 TPS V Garden at North West of Highway & Service road Vile Parle (E),Mumbai -57	1450	Garden	M.C.G. M	M.C.G. M		Mali Room, Jogging Track		Previousl y plot was given on adoption . Adoptee wilingly surrende r plot.
10	80	CTS No FP NO 483,489 Garden plot at junction of Dayaldas road & Subway Vile Parle (E)	3328	Garden	Adoptee	M/s Swami Narayan Vishrant i Bhavan Trust	Agre eme nt Expir ed	Electric substation	Good	
11	68	Shyam Nagar Talao, CTS No 18 F,19D, Village Majas, Plot at Junction of Jogeshwari-Vikhroli Link road & B.T road Jogeshwari €, Mumbai -60.	5718	Garden	M.C.G. M	Mainten ance N.K Shah (J.V)	31- Mar- 16	Natural Pond	Good	

12	80	Sitaram Purshottam Sathe Udyan,CTS No . F.P 91, Tikka NO TPS II Vile Parle at junction of Malviya road & Park road Vile Parle €, Mumbai -57.	654	Garden	M.C.G. M	Khushbu Enterprises	31-Dec-16	Jogging Track	Good	
13	79	Swatantrya Veer Savarkar Udyan,CTS No 582 , Tikka No 41,42. Vile Parle, on the south of Shan Cinema MG road Vile Parle (E, Mumbai -57.	3264	Garden	M.C.G. M	Khushbu Enterprises	31-Dec-16	Jogging Track	Good	
14	74	CTS No 952, Tikka No 27 Garden at East of Marol Church & West of Marol Maroshi road Andheri (E)	8500	Garden	M.C.G. M	Khushbu Enterprises	31-Dec-16	Jogging Track	Good	
15	68	CTS No. 21/D Majas Village Jogeshwari €, Mumbai -60.	1218	Garden	M.C.G. M	Khushbu Enterprises	31-Dec-16	Jogging Track	Good	
16	80	CTS No.1025, FP No.112, of TPS-II, Malviya Road, Vile Parle (East), Mumbai - 57.	1092	Garden	M.C.G. M	M.C.G. M		Open Stage	satisfactory	
17	75	CTS No 445/B,445/C,448/B Hissa No 1, survey No 55 Near Lok bharati Marol Maroshi road Marol Andheri (E) Near A-5Bldg Lokbharati.	1449	R.G	M.C.G. M	M.C.G. M			Satisfactory	
18	80	F P 187, TPS 5, Service Road, (Nanda Patkar Road), Vile Parle (E)	3179	R.G (Additional)	M.C.G. M	Fully Encroached		Fully Encroached		Fully Encroached. Plot included in Garden list since past.
19	69	Sai- leela Manoranjan Maidan,CTS No.382(B) , Vijay Raut Marg,Village Mogra, Andheri (E)	1967	R.G.	MCGM	MCGM			Satisfactory	

20	68	Vijay Salaskar Udyan, CTS No. 1/D, Majas Village , Link Road,Andheri €, Mumbai -93.	9001	R.G.	MCGM	MCGM		Jogging Track, Library,Drinking Water facility, Toilet	Good	Presently maintained by M/s Oberoi
21	73	CTS No 55/7 Maheshwari Nagar Plot Kondivita, Andheri (E)	4185	R.G	Adoptee	M/s Maheshwari Nagar Federation	Agreement Expired	Jogging Track, Cricket Practice Net, Security Cabin, Toilet	Good	
22	74	Bharat van Udyan,CTS NO 132/A/C/D Village Marol, near Custom colony, Near Bamandaya pada Bus stop, Military Road, Andheri East	18892	R.G	Adoptee	M/s Military road residents Welfare Association	Agreement Expired	Musical Dancing Fountain, Jogging Track, Security Cabin, Hall, Toilet	Good	
23	68	CTS NO 191/5 Village Majas,S.V.P. Road, Poonam Nagar , Andheri (East), Mumbai - 93.	9458	R.G	Adoptee	Mahakali A.L.M.	Agreement Expired	Yoga center, Jogging track, Toilet	Good	
24	68	CTS NO 190/B, village Majas, Jogeshwari vikroli Link Road, , Andheri (East) , Mumbai - 93.	56137	R.G	Care taker	M/s. Matoshri Arts & Spots Club	Agreement Executed by Estate Dept.	Club House	Good	Shilpgram reservation included.
25	68	Meenatai Thakeray Maidan,CTS NO 188 & 189 , Village Majas, SVP Road Poonam Nagar ,Andheri (East), Mumbai -93.	13595	R.G	Adoptee	M/s. Shiv Samarth Shikshan Prasarak	Ageement Expired	Gymnasium, Library	Good	
26	75	CTS No 498A/2/3/4,448-D Hissa No 4, Survey No 56 Near Lokbharati Marol Maroshi road Marol Andheri (E) Near B-I, B-II Lokbharati Bldg, Andheri(East).	2589	R.G	M.C.G.M.	Maintenance N.K.Shah (J.V)	31-Mar-16	Jogging Track	Good	

27	76	CTS NO 131/A/1/D Charat singh colony – B D Sawant Road, Chakala, Andheri (E)	1372	R.G	M.G.C. M.	Mainten ance N.K.Sha h (J.V)	31- Mar- 16	Gymnasium	Good	
28	66	CTS NO 53 P, 54 P, Tikka No 13, Adjacent to Asmita high School, Western Express highway at Ajgoankar Plot, Village Majas, Andheri (E)	2185	R.G	M.G.C. M.	Mainten ance N.K.Sha h (J.V)	31- Mar- 16	Jogging Track, Toilet	Good	
29	68	Ashok Kamte Udyan,CTS NO 176 – A – 2, 175 Part and 175 Part Village Majas, Near St. Xavior School, Poonam Nagar, Andheri(East), Mumbai -93.	8500	R.G	M.G.C. M.	Mainten ance N.K.Sha h (J.V)	31- Mar- 16	Natural pond, Jogging Track, Security Cabin, Toilet	Good	
30	75	CTS No 298A/1 Village Marol, Near Kunti park society, Marol, Military road , near Mithi river, Andheri (East)	1419	R.G	M.G.C. M.	Khushb u Enterpri zes	31- Dec- 16	Gymnasium, Jogging Track	Good	
31	71	CTS 40 B Village Mogra, near Vikas tower, Near Amboli Railway crossing, Andheri (East).	1872	R.G	M.G.C. M.	Khushb u Enterpri zes	31- Dec- 16	Gymnasium & Balwadi	Good	
32	72	Shaheed Tukaram Ombale Manoranjan Maidan,CTS No 242, Tikka No 12-20 Known as Govind wadi Talao, west of Holy Spirit Convent School Gundavali, Andheri €, Mumbai - 93.	10932	R.G	M.G.C. M.	Khushb u Enterpri zes	31- Dec- 16	Mali Room, Jogging Track, Amphithetr e	Good	
33	73	CTS No 238/C,234 /D Village Mulgaon, Near Nelco company ,Mahakali Caves road, Andheri (East) , Mumbai - 93.	3117	R.G	M.G.C. M.	Khushb u Enterpri zes	31- Dec- 16	Jogging Track	Good	

34	69	Mahakali Ganesh Maidan, CTS NO 522 (P) 524, 525, 526, Opposite Satya Sai Baba temple, Mahakali Caves Road, Andheri (East), Mumbai -93.	4000	R.G	M.G.C. M.	Khushbu Enterprises	31-Dec-16	Open Stage	Good	
35	73	CTS NO 294/D Hissa No 3,4 & 5 Survey No 24 Village Gundavali, Chintamani Plaza, A K Road, Gundavali, Andheri(East)	1994	R.G	M.G.C. M.	Khushbu Enterprises	31-Dec-16	Mali Chowky, Nursery Shed	Good	
36	76	CTS NO 443/B, Hissa No 10, Survey No 56, Kondivita Plot, Bagarka Road, Andheri (E)	45	R.G	M.G.C. M.	Khushbu Enterprises	31-Dec-16	Nil	Good	
37	75	Veer Abdul Hameed Manoranjan Maidan, CTS NO 1613/4B/1, Hissa No 1 part, Survey No 86, Hiss No 2,5,7,10, 11 part, Survey No 113, Kondivita Village, Lele Wadi, Village Marol, Andheri (East)	3912	R.G	M.G.C. M.	Khushbu Enterprises	31-Dec-16	Gymnasium	Good	
38	76	Mother Teresa Udyan, CTS No 398/B/part R.G & CTS No 398/C and 398/D part Park, Survey No 89 A1 Near Tarun Bharat society, village Chakala, Andheri (E)	1323	R.G. & Park	M.G.C. M.	Khushbu Enterprises	31-Dec-16	Play App., Jogging Track	Good	Two Reservations
39	69	CTS NO 368/2C Village Mogra,, Opposite Sarvodaya Nagar, Andheri (E)	2484	R.G	M.G.C. M.	Khushbu Enterprises	31-Dec-16	Play App., Jogging Track	Good	
40	80	F P No 108, TPS 1, Service Road, Vile Parle (E)	440	R.G	M.G.C. M.	Khushbu Enterprises	31-Dec-16	Ashok Stambha	Good	

41	75	CTS No. 1498 A/5 ,Village Marol , Opposite Cube Plaza,Andhri (E)	752	R.G.	M.G.C. M.	Khushbu Enterprises	31-Dec-16	Play App.	Good	
42	75	CTS No. 1498 A/6 ,Village Marol ,Opposite Cube Plaza, Andhri (E)	805	R.G	M.G.C. M.	Khushbu Enterprises	31-Dec-16	Play App.	Good	
43	68	CTS No. 175 A (pt) village Majas , Opposite ALM Park, SVP Road, Poonam Nagar,Andheri (East), Mumbai - 93.	5142	R.G	M.G.C. M.	Khushbu Enterprises	Good	Play App., Jogging Track	Good	
44	75	CTS no 131/A/1/E Plot at Andheri Ghatkopar Link Road, Village Chakala, Andheri (E)	1446	Park	M.C.G. M	M.C.G. M			Good	
45	78	Ramesh More Park, CTS NO 523, 522, 524 Hissa No 8 Village Gundavali, Known as Vaikunth Park, , Telli Galli, Gundavali, Andheri (East)	5240	Park	Care taker	M/s. Reliance Energy	Agreement Executed by Estate Dept.	Jogging Track , Play App.	Good	Electric substation Fountain
46	79	Prabhodankar Thackeray Swimming Pool,CTS NO 252 part, 255 part, 256 part, 257, 258, 259 260 part, 261, 262, 270, 271 part, 272 part, 274/2 part,435 part, Hissa No 23 , junction of M G Road and Shahaji Raje Marg, Vile Parle (East0, Mumbai - 57.	9230	Park & P. G.	Care taker	M/S Chattrapati Shivaji Smarak Samiti Trust	Agreement Executed by Estate Dept.	Swimming Pool, Security chowky, Toilet	Good	P.G. plot included
47	79	Anandibai Keskar Park ,F P No 72, TPS 1, MG Road, Opposite BMC School, Market, Vile Parle (East), Mumbai - 57.	1358	Park	M.G.C. M.	Khushbu Enterprises	31-Dec-16		Good	
48	67	CTS No 228/B, survery No 11, Hissa No 2 P, 85 part, Plot behind Pratap Nagar Cemetery, village	237	Park	M.G.C. M.	Khushbu Enterprises			Good	

		Majas, Jogeshwari €, Mumbai - 60.								
49	76	MeenaTai Thackeray Udyan, CTS NO 30, 37 part, 338 part, Hissa No 15/16 , Village Chakala, 30 Ft, DP Road in Tarun Bharat Co-operative housing society, Andheri (E)	875	P. G	M.C.G. M	M.C.G. M		Health Centre	Satisfactory	
50	68	CTS NO 169/3 Village Majas, Poonam Nagar, Andheri (E)	946	P. G	M.C.G. M	M.C.G. M			Satisfactory	
51	79	Hegdewar Maidan, CTS No FP NO 1 and 2, , Hanuman Road, Vile Parle (East), Mumbai- 57.	922	P. G	M.C.G. M	M.C.G. M		Gymnasium, Toilet	Satisfactory	
52	78	CTS NO 458 part, 459 part, Saiwadi Teli Galli, Andheri (E)	1650	P. G						Plot given for temporary transit camp to S.R.A.
53	70	CTS NO 330 part at Shankar Wadi, Mogra village, Near Express Highway, Lal Killa School, Jogeshwari (E)	11500	P. G						Plot given for temporary transit camp to S.R.A.
54	68	CTS No 168/6, 167 A part, Survey No 34, Hissa No 2, Poonam Nagar, Village Majas, Andheri (E)	2260	P. G	M.C.G. M	M.C.G. M			Satisfactory	
55	80	CTS NO 424, TPS 5, NP Thakker Road, VileParle (East), Mumbai -57.	975	P. G	M.C.G. M	M.C.G. M		Play App., Ring Well	Satisfactory	
56	79	CTS NO 418/C at Shahaji Raje Marg, Near BMC School, Vile Parle (E)Mumbai-57	1928	P. G	M.C.G. M	Khushbu Enterprises	31-Dec-16	Gymnasium, Play App	Good	
57	74	CTS No. 1296 S.No.153 Hissa No.l(pt) Near Hasnathh Highschool,	1069	P. G	M.C.G. M.	M.C.G. M.		Jogging Track	Satisfactory	

		Marol Andheri (E)								
58	78	CTS No. 109/B/2,Village Vile Parle (E) Malvia Road	633	P. G	M.C.G. M.	M.C.G. M.			Satisfactory	
59	76	CTS No. 175 B,176 A Of village chakala and CTS No. 8pt of village Sahar Andheri (E)	3029	P.G	M.C.G. M.	M.C.G. M.			Satisfactory	
60	75	CTS NO 294, Tikka No 16, 17 at Sahar Tank Pakhadi, Sahar Goan, south of Indian Oil Depot, Vile Parle (E)	7940	P. G	Adoptee	M/S Our Lady of Health high School	Agreement Expired	Gymnasium, Mali chowky, Toilet	Good	
61	73	CTS No 92-A ½, Survey No 71, Hissa No 3(P), Near Charat singh colony, Chakala, Andheri (E) Nr Gayatri Apartment	1354	P. G	Adoptee	M/S G B Pant Foundation	Agreement Expired		Good	
62	71	CTS No 40/E, Near Amboli Railway Crossing, Village mogra, Andheri (E)	1445	P. G	Adoptee	M/S Nikhunj Education Trust	Agreement Expired		Good	
63	69	CTS NO 481, Meghwadi, Sarvodaya Nagar, Andheri (E)	5290	P. G	M.C.G. M.	Khushbu Enterprises	31-Dec-16	Jogging Track,Health Centre	Good	
64	76	CTS NO 431/A and 501 part near Mistry Complex, Kondivita, Andheri (E)	3347	P. G	M.C.G. M.	Khushbu Enterprises	31-Dec-16	Gymnasium, Jogging Track	Good	
65	69	Chattrapati Shivaji Maharaj Kreedangan, CTS No 371/B,373, 375/B, 375/C, 376 Village Mogra, Vastu Appartments, Andheri (E),	5432	P. G	M.C.G. M.	Khushbu Enterprises	31-Dec-16	Gymnasium, Jogging Track	Good	
66	69	CTS No 368/294, Near Sanket mochan Hanuman Mandir, Mahakali Caves, Shere Punjab Society, Andheri (E)	6442	P. G	M.C.G. M.	Khushbu Enterprises	31-Dec-16	Jogging Track	Good	

67	69	CTS No, 368/2A and 2 B, Near Sarvodaya Nagar Play Ground, Shere Punjab Society, Andheri (E)	5230	P. G	M.C.G. M.	M.C.G. M.	31-Dec-16	Toilet	Good	
68	80	CTS NO FP NO 296, TPS 2, Waman Mangesh Dubhashi Play Ground at Play ground and Cross Road, Vile Parle (E)Mumbai-57	4710	P.G.	M.C.G. M.	M.C.G. M.	31-Dec-16	Jogging Track, Play App., Gymnasium, Security Cabin	Good	
69	66	CTS No. 60 , Village Ismalia ,Jogeshwari (E)	628	P. G	M.C.G. M.	Khushbu Enterprises	31-Dec-16	Security Cabin	Good	
70	78	CTS No.399 Teli Gully Andheri (E)	858	P. G	M.C.G. M.	Khushbu Enterprises	31-Dec-16	Gymnasium, Jogging Track	Good	

GANAPATI EMMERSION DETAILS YEAR- 2013

LOKMANYA TILAK GANESH VISARJAN TALAV, SHAM NAGAR, JOGESHWARI (E)					DR. HEDGEWAR ARTIFICIAL TALAV, HANUMAN ROAD, VILE PARLE (E)			
Day	Ganapati		GAURI	Total	Ganapati		GAURI	Total
	Domestic	Public			Domestic	Public		
10/9/2013	1459	3	0	1462	1077	2	0	1079
13/09/2013	1341	14	154	1509	531	5	39	575
15/09/2013	176	14	0	190	45	0	0	45
18/09/2013	518	61	5	584	131	2	0	133
Total	3494	92	159	3745	1784	9	39	1832